

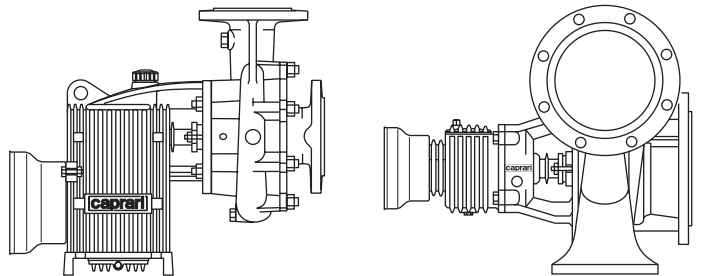

**POMPE CENTRIFUGHE CARRELLATE  
PER TRATTORI**  
*TRAILER MOUNTED CENTRIFUGAL TRACTOR PUMPS*  
**POMPES CENTRIFUGES A MULTIPLICATEUR  
POUR TRACTEURS**

**MEC-D/DMR-BHD**



prodotto conforme  
D.M.174/2004



**caprari**

pumping power



# MEC-D/DMR-BHD

SERIE  
SERIES  
SERIE

DIMENSIONI DI INGOMBRO E PESI  
OVERALL DIMENSIONS AND WEIGHT  
DIMENSIONS D'ENCOMBREMENT ET POIDS

| Moltiplicatore giri/rapporto<br>Step-up gear<br>r.p.m/ratio<br>Multiplificateur tours/rapport | TIPO<br>TYPE<br>TYPE | Girante tipo<br>Impeller type<br>Roue type | H-P | PORTATA - CAPACITY - DEBIT...<br>l/min<br>mc/h<br>l/sec |             |             |             |             |             |             |             |             |             |             |             |             |              |             |             |             |             |             |            |             |
|---|----------------------|--|-----|---|-------------|-------------|-------------|-------------|-------------|-------------|-------------|-------------|-------------|-------------|-------------|-------------|--------------|-------------|-------------|-------------|-------------|-------------|------------|-------------|
|   |                      |  |     | 200   | 250         | 300         | 350         | 400         | 450         | 500         | 550         | 600         | 700         | 800         | 900         | 1000        | 1100         | 1200        | 1300        | 1400        | 1600        | 1800        |            |             |
|   |                      |  |     | 12  | 15          | 18          | 21          | 24          | 27          | 30          | 33          | 36          | 42          | 48          | 54          | 60          | 66           | 72          | 78          | 84          | 96          | 108         |            |             |
| <b>CARATTERISTICHE DI FUNZIONAMENTO - OPERATING DATA - CARACTERISTIQUES DE FONCTIONNEMENT</b> |                      |  |     |   |             |             |             |             |             |             |             |             |             |             |             |             |              |             |             |             |             |             |            |             |
| 485/1:8,27<br>540/1:7,43  | MEC - D 2/40         | C  | P   | H   | 87<br>10,6  | 86<br>11,5  | 85<br>12,4  | 84<br>13,2  | 82<br>14    | 80<br>14,9  | 78<br>15,7  | 75<br>16,5  | 73<br>17,1  | 66<br>18,2  |             |             |              |             |             |             |             |             |            |             |
|   |                      | A  | P   | H   | 103<br>13,1 | 102<br>14,2 | 102<br>15,5 | 101<br>16,5 | 100<br>17,6 | 98<br>18,7  | 96<br>19,7  | 94<br>20,5  | 92<br>21,5  | 87<br>23    |             |             |              |             |             |             |             |             |            |             |
| 460/1:6,28<br>540/1:5,37  | MEC - DMR 50 - 1/2   | E  | P   | H   | 112<br>14   | 112<br>15,5 | 111<br>16,5 | 109<br>17,5 | 107<br>18,8 | 105<br>20   | 102<br>21   | 98<br>22    | 94<br>23    | 84<br>25    |             |             |              |             |             |             |             |             |            |             |
|   |                      | C  | P   | H   | 124<br>16,5 | 124<br>17,8 | 123<br>19,2 | 122<br>20,5 | 120<br>22   | 118<br>23   | 115<br>24,5 | 112<br>25,5 | 109<br>27   | 101<br>29   |             |             |              |             |             |             |             |             |            |             |
|   |                      | A  | P   | H   | 139<br>19,9 | 139<br>21,5 | 138<br>23   | 137<br>24,5 | 136<br>26   | 134<br>27,5 | 132<br>29   | 128<br>30   | 125<br>31,5 | 117<br>33,5 |             |             |              |             |             |             |             |             |            |             |
| 540/1:6,28  |                      | E  | P   | H   | 152<br>21   | 152<br>23   | 151<br>24,5 | 150<br>26   | 148<br>28   | 146<br>30   | 143<br>31,5 | 140<br>33   | 137<br>34,5 | 129<br>37   |             |             |              |             |             |             |             |             |            |             |
|   |                      | C  | P   | H   | 169<br>25   | 169<br>27   | 168<br>29   | 168<br>30,5 | 167<br>32,5 | 165<br>34   | 163<br>36   | 160<br>38   | 157<br>39,5 | 149<br>43   |             |             |              |             |             |             |             |             |            |             |
| 485/1:8,27<br>540/1:7,43  | MEC - D 1/50         | B  | P   | H   |             |             |             |             |             |             | 56<br>10,5  | 56<br>11    | 55<br>11,5  | 54<br>12,5  | 53<br>13,5  | 51<br>14,4  | 48,5<br>15,2 | 46<br>16    |             |             |             |             |            |             |
|   |                      | A  | P   | H   |             |             |             |             |             |             | 64<br>12,2  | 64<br>12,8  | 63<br>13,4  | 62<br>14,6  | 61<br>15,7  | 59<br>16,9  | 57<br>18     | 54<br>18,9  |             |             |             |             |            |             |
| 485/1:8,27<br>540/1:7,43  | MEC - D 2/50         | D  | P   | H   |             |             |             |             |             |             | 74<br>14    | 73<br>14,7  | 72<br>15,4  | 70<br>16,9  | 66<br>18    | 63<br>19    | 59<br>20     | 54<br>21    |             |             |             |             |            |             |
|   |                      | C  | P   | H   |             |             |             |             |             |             | 85<br>17    | 84<br>17,9  | 83<br>18,5  | 81<br>20    | 78<br>22    | 75<br>23    | 71<br>24     | 66<br>25    |             |             |             |             |            |             |
|   |                      | B  | P   | H   |             |             |             |             |             |             | 95<br>21,5  | 95<br>22    | 94<br>23    | 92<br>25,5  | 89<br>27    | 86<br>28,5  | 82<br>28     | 77<br>28,5  |             |             |             |             |            |             |
| 460/1:7,42<br>540/1:6,28<br>500/1:6,77  | MEC - D 3/50         | B  | P   | H   |             |             |             |             |             |             | 108<br>24,5 | 107<br>25,5 | 105<br>26,5 | 103<br>29   | 99<br>31    | 94<br>33    | 88<br>34     | 83<br>35    |             |             |             |             |            |             |
|   |                      | A  | P   | H   |             |             |             |             |             |             | 119<br>28,5 | 118<br>29   | 117<br>31   | 114<br>33,5 | 111<br>36   | 106<br>38   | 101<br>39,5  | 96<br>41    |             |             |             |             |            |             |
| 540/1:5,37  | MEC - DMR 50 - 2/2   | C  | P   | H   |             |             |             |             |             |             | 129<br>26,5 | 127<br>28   | 126<br>29   | 121<br>31,5 | 114<br>33,5 | 106<br>35,5 | 98<br>36,5   |             |             |             |             |             |            |             |
|   |                      | A  | P   | H   |             |             |             |             |             |             | 144<br>30,5 | 143<br>32   | 141<br>34   | 136<br>36   | 130<br>38,5 | 122<br>41   | 112<br>43    |             |             |             |             |             |            |             |
| 485/1:8,27<br>540/1:7,43  | MEC - D 1/65         | B  | P   | H   |             |             |             |             |             |             |             |             |             |             | 56<br>16    | 55<br>17    | 54<br>18     | 53<br>18,5  | 52<br>19,5  | 51<br>20    | 49<br>21    | 45<br>22    |            |             |
|   |                      | A  | P   | H   |             |             |             |             |             |             |             |             |             |             | 65<br>20    | 65<br>21,5  | 64<br>22     | 63<br>23,5  | 62<br>24,5  | 61<br>25,5  | 60<br>26,5  | 57<br>28    |            |             |
| 460/1:7,42<br>540/1:6,28<br>500/1:6,77  | MEC - D 2/65         | B  | P   | H   |             |             |             |             |             |             |             |             |             |             | 72<br>21    | 72<br>22    | 71<br>24     | 70<br>25,5  | 69<br>27    | 68<br>28    | 66<br>29    | 66<br>31,5  |            |             |
|   |                      | A  | P   | H   |             |             |             |             |             |             |             |             |             |             | 76<br>24    | 76<br>26    | 75<br>27     | 75<br>28,5  | 74<br>30    | 73<br>31    | 72<br>32,5  | 70<br>35    |            |             |
| 460/1:7,42<br>500/1:6,77<br>540/1:6,28  | MEC - D 3/65         | D  | P   | H   |             |             |             |             |             |             |             |             |             |             | 94<br>28    | 93<br>30    | 92<br>31,5   | 91<br>33    | 89<br>35    | 87<br>36,5  | 86<br>38    | 82<br>41    |            |             |
|   |                      | C  | P   | H   |             |             |             |             |             |             |             |             |             |             | 102<br>31   | 101<br>33   | 100<br>35    | 99<br>37    | 98<br>39    | 97<br>41    | 96<br>42,5  | 92<br>46    |            |             |
|   |                      | B  | P   | H   |             |             |             |             |             |             |             |             |             |             | 112<br>35   | 111<br>37   | 110<br>39    | 109<br>41   | 108<br>43,5 | 106<br>45,5 | 105<br>47,5 | 101<br>51   |            |             |
| 530/1:5,69  | MEC - DMR 65 - 2/2   | E  | P   | H   |             |             |             |             |             |             |             |             |             |             | 129<br>34,5 | 128<br>36,5 | 126<br>39    | 124<br>41   | 121<br>43   | 117<br>45   | 114<br>47   | 109<br>49   | 99<br>52,5 | 88<br>55,5  |
|   |                      | C  | P   | H   |             |             |             |             |             |             |             |             |             |             | 144<br>39   | 143<br>41,5 | 141<br>44    | 139<br>46,5 | 136<br>49   | 133<br>51,5 | 129<br>53,5 | 125<br>55,5 | 116<br>59  | 105<br>62,5 |
|   |                      | A  | P   | H   |             |             |             |             |             |             |             |             |             |             | 158<br>44   | 157<br>46,5 | 156<br>49,5  | 154<br>52   | 151<br>55   | 148<br>57   | 144<br>59,5 | 141<br>62   | 132<br>66  | 122<br>69,5 |

H = Prevalenza manometrica totale in m.  
Total manometric head in m.  
Hauteur manométrique totale en m.

P = Potenza assorbita in HP.  
Absorbed power in HP.  
Puissance absorbée en HP.

| Moltiplicatore giri/rapporto<br>Step-up gear<br>r.p.m./ratio<br>Multiplicateur tours/rapport | TIPO<br>TYPE<br>TYPE | Girante tipo<br>Impeller type<br>Roue type | H-P | PORTATA - CAPACITY - DEBIT... $\frac{l}{min}$<br>$\frac{mc}{h}$<br>$\frac{l}{sec}$ |      |      |      |      |      |      |      |      |      |      |      |      |      |      |      |      |       |       |       |  |  |
|--|----------------------|--|-----|--|------|------|------|------|------|------|------|------|------|------|------|------|------|------|------|------|-------|-------|-------|--|--|
|  |                      |  |     | 800  | 1000 | 1200 | 1400 | 1600 | 1800 | 2000 | 2220 | 2400 | 2600 | 2800 | 3000 | 3500 | 4000 | 4500 | 5500 | 6000 | 7000  | 8000  | 8500  |  |  |
|  |                      |  |     | 48   | 60   | 72   | 84   | 96   | 108  | 120  | 132  | 144  | 156  | 168  | 180  | 210  | 240  | 270  | 330  | 360  | 420   | 480   | 510   |  |  |
|  |                      |  |     | 13,3   | 16,7 | 20   | 23,3 | 26,7 | 30   | 33,3 | 36,7 | 40   | 43,3 | 46,7 | 50   | 58,3 | 66,7 | 75   | 91,7 | 100  | 116,7 | 133,3 | 141,7 |  |  |
| CARATTERISTICHE DI FUNZIONAMENTO - CARACTERISTIQUES DE FONCTIONNEMENT - OPERANTING DATA      |                      |  |     |  |      |      |      |      |      |      |      |      |      |      |      |      |      |      |      |      |       |       |       |  |  |
| 460/1:7,42<br>500/1:6,77<br>540/1:6,28   | MEC - D 2/80         | B  | P   | H  |      |      |      |      |      |      |      |      |      |      |      |      |      |      |      |      |       |       |       |  |  |
|  |                      | A  | P   | H  |      |      |      |      |      |      |      |      |      |      |      |      |      |      |      |      |       |       |       |  |  |
| 490/1:5,69<br>540/1:5,21<br>730/1:3,83   | MEC - D 03/80        | A  | P   | H  |      |      |      |      |      |      |      |      |      |      |      |      |      |      |      |      |       |       |       |  |  |
|  |                      | F  | P   | H  |      |      |      |      |      |      |      |      |      |      |      |      |      |      |      |      |       |       |       |  |  |
|  | MEC - D 04/80        | E  | P   | H  |      |      |      |      |      |      |      |      |      |      |      |      |      |      |      |      |       |       |       |  |  |
|  |                      | D  | P   | H  |      |      |      |      |      |      |      |      |      |      |      |      |      |      |      |      |       |       |       |  |  |
|  |                      | C  | P   | H  |      |      |      |      |      |      |      |      |      |      |      |      |      |      |      |      |       |       |       |  |  |
| 510/1:5,69<br>755/1:3,83   | MEC - DMR 80 - 3/2   | E  | P   | H  |      |      |      |      |      |      |      |      |      |      |      |      |      |      |      |      |       |       |       |  |  |
|  |                      | D  | P   | H  |      |      |      |      |      |      |      |      |      |      |      |      |      |      |      |      |       |       |       |  |  |
|  |                      | C  | P   | H  |      |      |      |      |      |      |      |      |      |      |      |      |      |      |      |      |       |       |       |  |  |
| 510/1:5,69<br>555/1:5,21<br>755/1:3,83   | MEC - D 004/80       | C  | P   | H  |      |      |      |      |      |      |      |      |      |      |      |      |      |      |      |      |       |       |       |  |  |
|  |                      | B  | P   | H  |      |      |      |      |      |      |      |      |      |      |      |      |      |      |      |      |       |       |       |  |  |
|  |                      | A  | P   | H  |      |      |      |      |      |      |      |      |      |      |      |      |      |      |      |      |       |       |       |  |  |
| 836/1:3,35<br>731/1:3,83   | MEC - DMR 83 - 3/2   | A  | P   | H  |      |      |      |      |      |      |      |      |      |      |      |      |      |      |      |      |       |       |       |  |  |
|  |                      | B  | P   | H  |      |      |      |      |      |      |      |      |      |      |      |      |      |      |      |      |       |       |       |  |  |
| 835/1:3,35<br>757/1:3,83   |                      | A  | P   | H  |      |      |      |      |      |      |      |      |      |      |      |      |      |      |      |      |       |       |       |  |  |
|  |                      | B  | P   | H  |      |      |      |      |      |      |      |      |      |      |      |      |      |      |      |      |       |       |       |  |  |
| 895/1:3,35<br>785/1:3,83   | MEC - DMR 83 - 3/2   | A  | P   | H  |      |      |      |      |      |      |      |      |      |      |      |      |      |      |      |      |       |       |       |  |  |
|  |                      | B  | P   | H  |      |      |      |      |      |      |      |      |      |      |      |      |      |      |      |      |       |       |       |  |  |
| 490/1:5,69<br>540/1:5,21<br>730/1:3,83   | MEC - D 03/100       | C  | P   | H  |      |      |      |      |      |      |      |      |      |      |      |      |      |      |      |      |       |       |       |  |  |
|  |                      | B  | P   | H  |      |      |      |      |      |      |      |      |      |      |      |      |      |      |      |      |       |       |       |  |  |
|  |                      | A  | P   | H  |      |      |      |      |      |      |      |      |      |      |      |      |      |      |      |      |       |       |       |  |  |
| 532/1:5,69   | MEC - D 03/101       | A  | P   | H  |      |      |      |      |      |      |      |      |      |      |      |      |      |      |      |      |       |       |       |  |  |
|  |                      | B  | P   | H  |      |      |      |      |      |      |      |      |      |      |      |      |      |      |      |      |       |       |       |  |  |
| 865/1:3,35<br>757/1:3,83   | MEC - D 3/101        | A  | P   | H  |      |      |      |      |      |      |      |      |      |      |      |      |      |      |      |      |       |       |       |  |  |
|  |                      | B  | P   | H  |      |      |      |      |      |      |      |      |      |      |      |      |      |      |      |      |       |       |       |  |  |
| 895/1:3,35<br>785/1:3,83   |                      | A  | P   | H  |      |      |      |      |      |      |      |      |      |      |      |      |      |      |      |      |       |       |       |  |  |
|  |                      | B  | P   | H  |      |      |      |      |      |      |      |      |      |      |      |      |      |      |      |      |       |       |       |  |  |
| 925/1:3,35<br>810/1:3,83   |                      | A  | P   | H  |      |      |      |      |      |      |      |      |      |      |      |      |      |      |      |      |       |       |       |  |  |
|  |                      | B  | P   | H  |      |      |      |      |      |      |      |      |      |      |      |      |      |      |      |      |       |       |       |  |  |
| 955/1:3,35<br>835/1:3,83   | A                    | P  | H   |  |      |      |      |      |      |      |      |      |      |      |      |      |      |      |      |      |       |       |       |  |  |
|  | B                    | P  | H   |  |      |      |      |      |      |      |      |      |      |      |      |      |      |      |      |      |       |       |       |  |  |
| 540/1:3,83   | MEC - D 01/125       | A  | P   | H  |      |      |      |      |      |      |      |      |      |      |      |      |      |      |      |      |       |       |       |  |  |
| 500/1:2,93   | BHD200               | A  | P   | H  |      |      |      |      |      |      |      |      |      |      |      |      |      |      |      |      |       |       |       |  |  |

H = Prevalenza manometrica totale in m.  
Total manometric head in m.  
Hauteur manométrique totale en m.

P = Potenza assorbita in HP.  
Absorbed power in HP.  
Puissance absorbée en HP.

# MEC-D/DMR-BHD

SERIE  
SERIES  
SERIE

DIMENSIONI DI INGOMBRO E PESI  
OVERALL DIMENSIONS AND WEIGHT  
DIMENSIONS D'ENCOMBREMENT ET POIDS

| ACCOPIAMENTI - COUPLINGS - ACCOUPLEMENTS |                      |   |  |              |  |   |         |
|--|----------------------|---|--|--------------|--|---|---------|
| DNa<br>x<br>DNm                          | TIPO<br>TYPE<br>TYPE | Girante<br>tipo<br>Impeller<br>type<br>Roue<br>type | Potenza nomin.<br>trattore<br>Rated output of<br>the tractor<br>Puissance nom.<br>tracteur |              | Carrello<br>tipo<br>Trailer<br>type<br>Chariot<br>type | Albero cardanico tipo<br>Cardanic shaft type<br>Aibre à cardan type |         |
|  |                      |   | HP   | kW           |  |   |         |
|  |                      |   | 50 x 40  | MEC - D 2/40 |  |   | C       |
| 65 x 50                                  | MEC - DMR 50 - 1/2   | A   | 30 ÷ 35  | 22 ÷ 28      | C4   | AC6   |         |
|  |                      | E   | 35 ÷ 40  | 28 ÷ 30      |  |   |         |
|  |                      | C   | 42 ÷ 45  | 31 ÷ 33      |  |   |         |
|  |                      | A   | 45 ÷ 50  | 33 ÷ 37      |  |   |         |
|  |                      | E   | 55   | 40           |  |   |         |
|  |                      | C   | 55 ÷ 62  | 40 ÷ 46      |  |   |         |
|  | MEC - D 1/50         | B   | 20 ÷ 22  | 15 ÷ 16      | C3   | AC4   |         |
|  |                      | A   | 25 ÷ 30  | 18 ÷ 22      |  |   |         |
|  |                      | D   | 28 ÷ 33  | 21 ÷ 24      |  |   |         |
|  |                      | MEC - D 2/50  | C  | 35 ÷ 40      |  |   | 28 ÷ 30 |
|  |                      |   | B  | 40 ÷ 42      |  |   | 30 ÷ 31 |
|  |                      | MEC - D 3/50  | B  | 50 ÷ 55      |  |   | 37 ÷ 40 |
| A  | 60 ÷ 62              |   | 45 ÷ 46  |              |  |   |         |
| C  | 55                   |   | 40   |              |  |   |         |
| B  | 62 ÷ 65              |   | 46 ÷ 48  |              |  |   |         |
| 80 x 65                                  | MEC - D 1/65         | B   | 30 ÷ 35  | 22 ÷ 28      | C3   | AC5   |         |
|  |                      | A   | 40 ÷ 42  | 30 ÷ 31      |  |   |         |
|  | MEC - D 2/65         | B   | 50   | 37           | C4   | AC6   |         |
|  |                      | A   | 50 ÷ 55  | 37 ÷ 40      |  |   |         |
|  |                      | D   | 60 ÷ 62  | 45 ÷ 46      |  |   |         |
|  | MEC - D 3/65         | C   | 65 ÷ 70  | 48 ÷ 51      | C4   | AC8   |         |
|  |                      | B   | 74 ÷ 78  | 54 ÷ 57      |  |   |         |
|  |                      | E   | 75 ÷ 85  | 55 ÷ 62      |  |   |         |
|  | MEC - DMR 65 - 2/2   | C   | 80 ÷ 90  | 59 ÷ 66      | C2   | AC9   |         |
|  |                      | A   | 100  | 75           |  |   |         |
|  | 100 x 80             | MEC - D 2/80  | B  | 65 ÷ 70      | 48 ÷ 51  | C4  | AC8     |
|  |                      |   | A  | 72 ÷ 78      | 53 ÷ 57  |   |         |
| MEC - D 03/80                            |                      | A   | 75 ÷ 85  | 55 ÷ 62      | C2   | AC9   |         |
|  |                      | F   | 80 ÷ 90  | 59 ÷ 66      |  |   |         |
|  |                      | E   | 100  | 75           |  |   |         |
|  |                      | D   | 100 ÷ 110  | 75 ÷ 81      |  |   |         |
|  |                      | C   | 100 ÷ 120  | 81 ÷ 88      |  |   |         |
| MEC - DMR 80 - 3/2                       |                      | E   | 100 ÷ 110  | 75 ÷ 81      |  |   |         |
|  |                      | D   | 120 ÷ 130  | 88 ÷ 96      |  |   |         |
|  |                      | C   | 130  | 96           |  |   |         |
| MEC - D 004/80                           |                      | C   | 110  | 81           |  |   |         |
|  |                      | B   | 110 ÷ 120  | 81 ÷ 88      |  |   |         |
| 125 x 100                                | MEC - D 03/100       | A   | 100  | 81           | C2   | AC9   |         |
|  |                      | B   | 100 ÷ 110  | 75 ÷ 81      |  |   |         |
|  |                      | C   | 100  | 75           |  |   |         |
| 150 x 125                                | MEC - D 03/101       | A   | 140 ÷ 150  | 103 ÷ 110    | C2   | AC9   |         |
| 200 x 200                                | BDH200               | A   | 45 ÷ 50  | 33 ÷ 37      |  |   | AC5     |

| ACCOPIAMENTI - COUPLINGS - ACCOUPLEMENTS |                      |   |  |  |                    |  |   |
|--|----------------------|---|--|--|--------------------|--|---|
| DNa<br>x<br>DNm                          | TIPO<br>TYPE<br>TYPE | Girante<br>tipo<br>Impeller<br>type<br>Roue<br>type | Giri al minuto<br>Revolutions per minute<br>Tours par minute | Potenza nomin.<br>trattore<br>Rated output of<br>the tractor<br>Puissance nom.<br>tracteur |                    | Carrello<br>tipo<br>Trailer<br>type<br>Chariot<br>type | Albero cardanico tipo<br>Cardanic shaft type<br>Aibre à cardan type |
|  |                      |   |  | HP   | kW                 |  |   |
|  |                      |   |  | 100 x 80   | MEC - DMR 83 - 3/2 |  |   |
| B  |                      | 130 ÷ 140   | 96 ÷ 103   |  |                    |  |   |
| A  | n = 2900             | 140 ÷ 150   | 103 ÷ 110  |  |                    |  |   |
| B  |                      | 140 ÷ 150   | 103 ÷ 110  |  |                    |  |   |
| A  | n = 3000             | 150 ÷ 160   | 110 ÷ 118  |  |                    |  |   |
| B  |                      | 150 ÷ 160   | 110 ÷ 118  |  |                    |  |   |
| 125 x 100                                | MEC - D 3/101        | A   | n = 2900   | 130 ÷ 140  | 96 ÷ 103           | C2   | AC9/1   |
|  |                      | B   |  | 130 ÷ 140  | 96 ÷ 103           |  |   |
|  |                      | A   | n = 3000   | 140 ÷ 150  | 103 ÷ 110          |  |   |
|  |                      | B   |  | 140 ÷ 150  | 103 ÷ 110          |  |   |
|  |                      | A   | n = 3100   | 160 ÷ 170  | 118 ÷ 125          |  |   |
|  |                      | B   |  | 160 ÷ 170  | 118 ÷ 125          |  |   |
|  |                      | A   | n = 3200   | 170 ÷ 180  | 125 ÷ 132          |  |   |
|  |                      | B   |  | 170 ÷ 180  | 125 ÷ 132          |  |   |

**N.B. La potenza resa in servizio continuo alla p.d.f. è, indicativamente, pari al 70% della potenza nominale del trattore.**

Power available at p.t.o. for continuous service is approx. 70% of the tractor nominal power.

La puissance disponible en service continu à la prise de force est, indicativement, de 70% de la puissance nominale du tracteur.

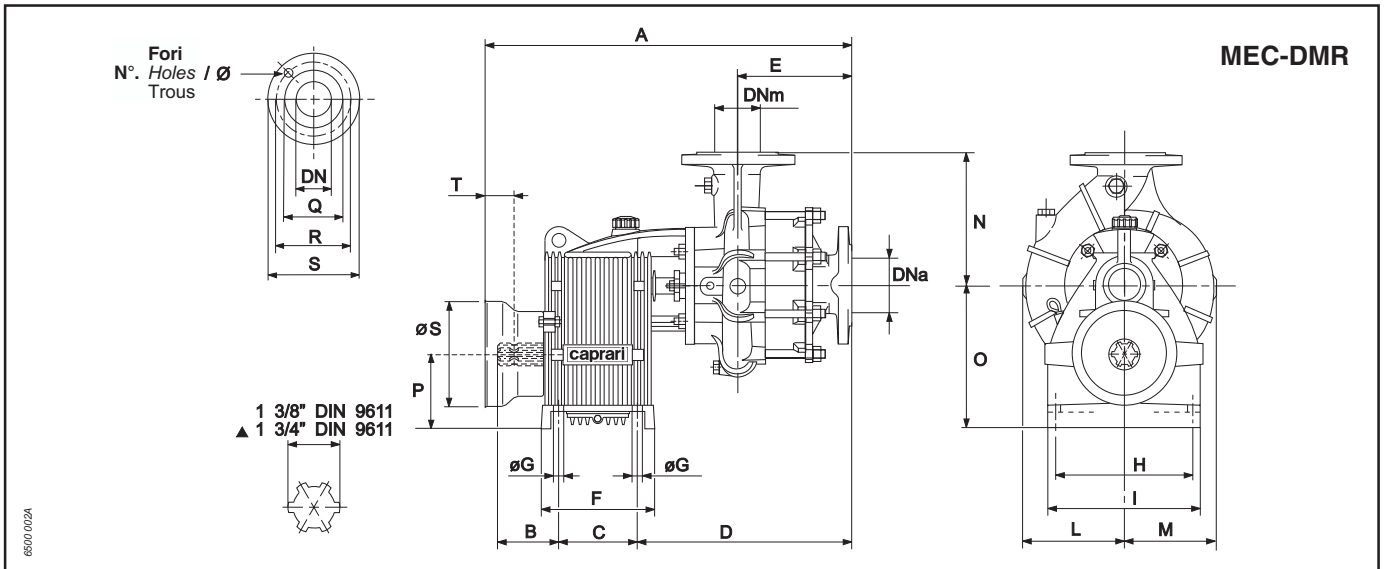
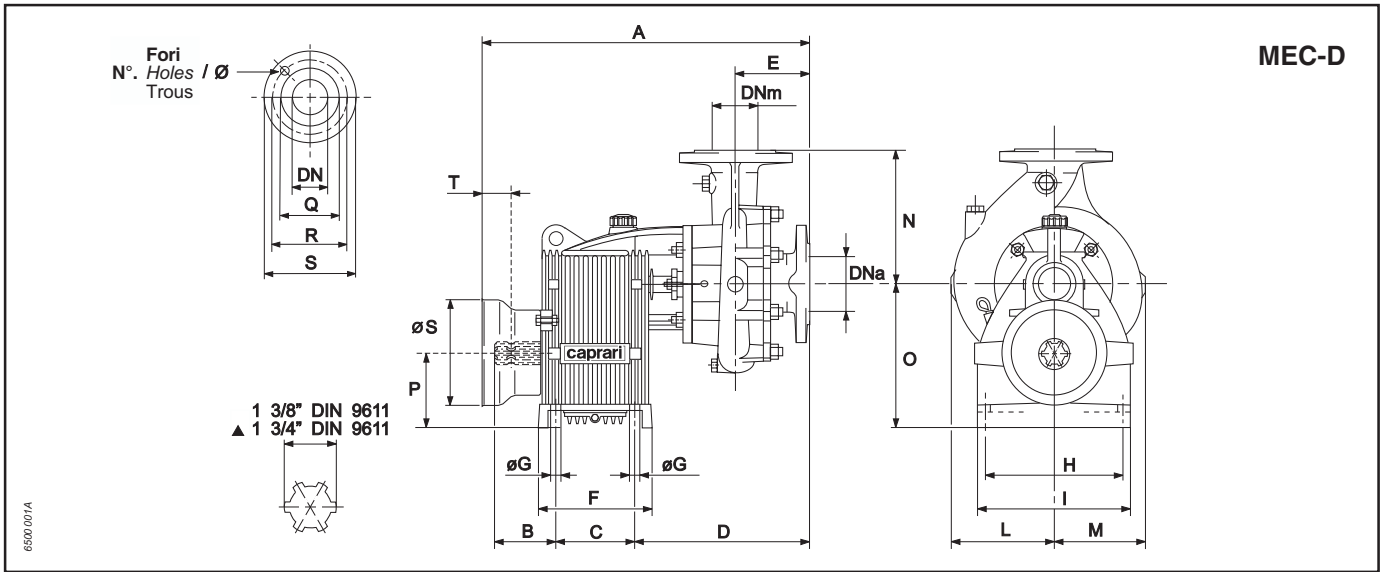

| Pompa tipo<br>Pump type<br>Pompe type | DNa    | DNm | A   | B   | C     | D   | E   | F   | G   | H  | I   | L   | M   | N   | O   | P   | Ø S | T   | Peso<br>Weight<br>Poinds<br>kg | Flange - Bride - Flanges  |   |   |   |                                 |
|---------------------------------------|--------|-----|-----|-----|-------|-----|-----|-----|-----|----|-----|-----|-----|-----|-----|-----|-----|-----|--------------------------------|---|---|---|---|---------------------------------|
|                                       |        |     |     |     |       |     |     |     |     |    |     |     |     |     |     |     |     |     |                                | Ø Bocca<br>Ports Ø<br>Ø Orifice   | Q | R | S | Fori<br>Holes<br>Trous<br>N°. Ø |
| <b>MEC - D</b>                        | 2/40   | 50  | 40  | 546 |       |     | 251 | 104 |     |    |     | 140 | 128 | 200 |     |     |     | 118 | 48                             | 4<br>18<br>8<br>22<br>18<br>N.B.<br>▲ Le pompe MEC - DMR83 - 3/2 e MEC - D3/101 hanno una p.d.f. di 1 3/4" DIN 9611.<br>N.B.<br>▲ Gear shaft 1 3/4" (DIN 9611) for pumps MEC - DMR83 - 3/2 and MEC - D3/101.<br>N.B.<br>▲ Bout d'arbo 1 3/4" (DIN 9611) pour multiplicateur des pompes MEC - DMR83 - 3/2 et MEC - D3/101. |   |   |   |                                 |
|                                       | 1/50   |     |     | 94  | 110   |     | 255 | 108 | 152 | 14 | 205 | 230 | 133 | 114 | 175 | 217 | 110 | 128 | 45                             |   |   |   |   |                                 |
|                                       | 2/50   | 65  | 50  | 550 |       |     |     |     |     |    |     |     | 150 | 135 | 225 |     |     | 126 | 49                             |   |   |   |   |                                 |
|                                       | 3/50   |     |     | 597 | 100   | 135 | 274 | 113 | 180 | 15 | 235 | 260 | 175 | 164 | 250 | 244 | 125 | 126 | 67                             |   |   |   |   |                                 |
|                                       | 1/65   |     |     | 551 | 94    | 110 | 256 | 109 | 152 | 14 | 205 | 230 | 145 | 120 | 200 | 217 | 110 | 128 | 46                             |   |   |   |   |                                 |
|                                       | 2/65   | 80  | 65  | 603 |       |     | 280 | 119 |     |    |     |     | 165 | 144 | 225 |     |     | 126 | 68                             |   |   |   |   |                                 |
|                                       | 3/65   |     |     | 603 | 100   | 135 | 280 | 119 | 180 | 15 | 235 | 260 | 188 | 168 | 275 | 244 | 125 | 126 | 74                             |   |   |   |   |                                 |
|                                       | 2/80   |     |     | 607 |       |     | 284 | 123 |     |    |     |     | 180 | 152 | 250 |     |     | 126 | 75                             |   |   |   |   |                                 |
|                                       | 03/80  |     |     | 672 |       |     | 333 | 148 |     |    |     |     | 204 | 180 | 300 |     |     | 126 | 97                             |   |   |   |   |                                 |
|                                       | 04/80  | 100 | 80* | 677 |       |     | 338 | 153 | 207 |    |     |     | 244 | 222 | 325 | 260 | 135 | 240 | 110                            |   |   |   |   |                                 |
|                                       | 004/80 |     |     | 677 | 110,5 | 150 | 338 | 153 | 207 |    |     |     | 244 | 222 | 325 | 260 | 135 | 240 | 110                            |   |   |   |   |                                 |
|                                       | 03/100 |     |     | 671 |       |     | 332 | 147 |     | 18 | 225 |     |     |     |     |     |     | 116 | 106                            |   |   |   |   |                                 |
|                                       | 03/101 | 125 | 100 | 693 | 105   | 180 | 325 | 220 |     |    |     |     | 290 |     | 300 | 281 | 145 | 118 | 123                            |   |   |   |   |                                 |
|                                       | 3/101▲ |     |     | 693 | 105   | 180 | 325 | 220 |     |    |     |     | 290 |     | 300 | 281 | 145 | 118 | 123                            |   |   |   |   |                                 |
| 01/125                                | 150    | 125 | 688 | 110 | 150   | 349 | 164 | 207 |     |    |     | 280 | 225 | 178 | 260 | 135 | 116 | 130 |                                |   |   |   |   |                                 |
| <b>MEC - DMR</b>                      | 50-1/2 | 65  | 50  | 677 | 100   | 135 | 354 | 193 | 180 | 15 | 235 | 260 | 175 | 164 | 250 | 244 | 125 | 126 | 90                             |   |   |   |   |                                 |
|                                       | 50-2/2 |     |     | 677 | 100   | 135 | 354 | 193 | 180 | 15 | 235 | 260 | 175 | 164 | 250 | 244 | 125 | 126 | 90                             |   |   |   |   |                                 |
|                                       | 65-2/2 | 80  | 65* | 721 |       |     | 382 | 197 | 207 |    |     | 188 | 168 | 275 | 260 | 135 | 116 | 114 |                                |   |   |   |   |                                 |
|                                       | 80-3/2 |     |     | 763 | 110   | 150 | 424 | 239 | 207 | 18 | 255 | 280 | 188 | 168 | 275 | 260 | 135 | 116 | 121                            |   |   |   |   |                                 |
| 83-3/2▲                               | 100    | 80* | 785 | 105 | 180   | 417 | 220 | 220 |     |    |     | 204 | 180 | 300 | 281 | 145 | 118 | 138 |                                |   |   |   |   |                                 |

**MEC-D/DMR-BHD**

SERIE  
SERIES  
SERIE

DIMENSIONI DI INGOMBRO E PESI  
OVERALL DIMENSIONS AND WEIGHT  
DIMENSIONS D'ENCOMBREMENT ET POIDS

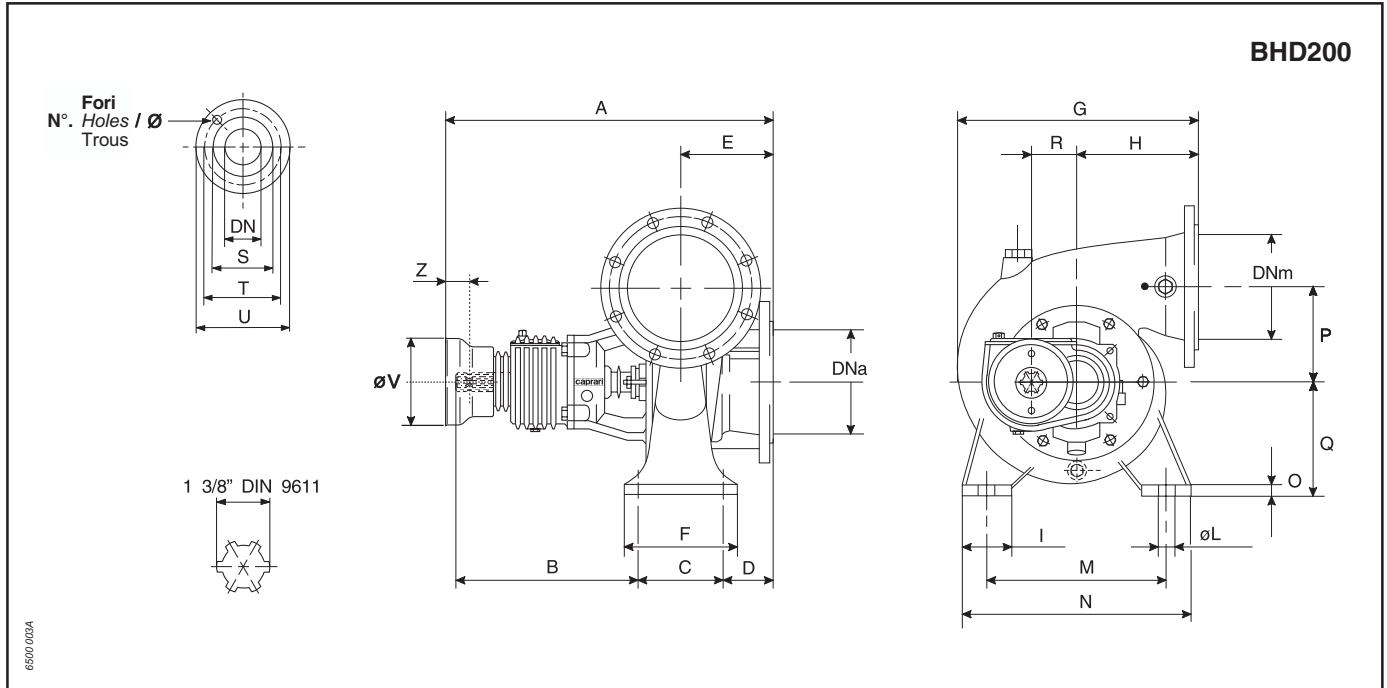

| Pompa tipo<br>Pump type<br>Pompe type | DNa | DNm | A   | B   | C   | D   | E   | F   | G   | H   | I   | L  | M   | N   | O  | P   | Q   | R  | ØV  | Z   | Peso<br>Weight<br>Poids<br>kg | Flange - Bride - Flanges        |     |     |     |                                 |    |
|---------------------------------------|-----|-----|-----|-----|-----|-----|-----|-----|-----|-----|-----|----|-----|-----|----|-----|-----|----|-----|-----|-------------------------------|---------------------------------|-----|-----|-----|---------------------------------|----|
|                                       |     |     |     |     |     |     |     |     |     |     |     |    |     |     |    |     |     |    |     |     |                               | Ø Bocca<br>Ports Ø<br>Ø Orifice | Q   | R   | S   | Fori<br>Holes<br>Trous<br>N°. Ø |    |
| <b>BHD200</b>                         | 200 | 200 | 697 | 367 | 180 | 190 | 180 | 220 | 463 | 230 | 100 | 19 | 350 | 450 | 20 | 190 | 225 | 88 | 203 | 100 | 133                           | DN                              | 250 | 280 | 320 | 8                               | 18 |

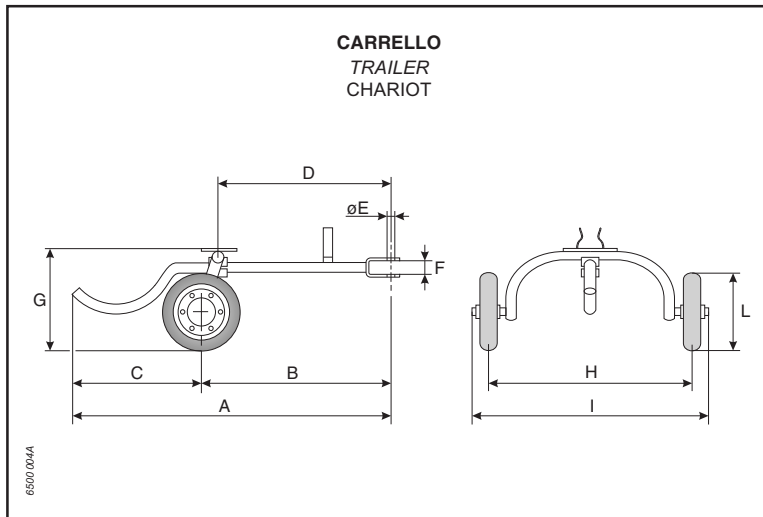

| Carrello tipo<br>Trailer type<br>Chariot type | A    |      | B    |     | C   |     | D    |      | E  | F  | G | H   | I    | L    | Peso in Kg<br>Weight in Kg<br>Poids en Kg |    |
|---|------|------|------|-----|-----|-----|------|------|----|----|---|-----|------|------|---|----|
|   | Min  | Max  | Min  | Max | Min | Max | Min  | Max  |    |    |   |     |      |      |   |    |
| <b>C2</b>                                     | 2015 | 1230 | 1480 |     |     |     | 1140 | 1390 |    |    |   | 534 | 1085 | 1282 | 400                                       | 45 |
| <b>C3</b>                                     | 1665 | 880  | 1130 | 625 | 875 |     | 790  | 1040 | 26 | 55 |   | 509 | 795  | 994  | 350                                       | 26 |
| <b>C4</b>                                     | 1765 | 980  | 1230 |     |     |     | 890  | 1140 |    |    |   | 527 | 905  | 1096 | 385                                       | 35 |

Portata max - Max load - Charge maxi: C2 = 200 Kg  
C3 = 80 Kg  
C4 = 140 Kg

Velocità max - Max speed - Vitesse maxi: 6 Km/m

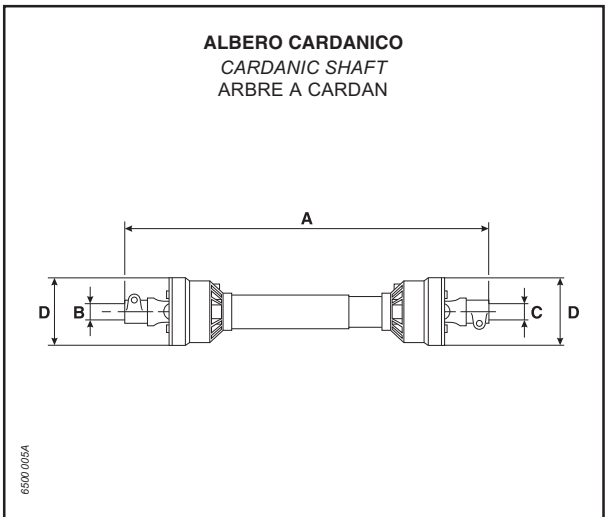

| Albero cardanico tipo<br>Cardanic shaft type<br>Arbre à cardan type | A   |      | B    | C      | D   | Peso in Kg<br>Weight in Kg<br>Poids en Kg |
|---|-----|------|------|--------|-----|---|
|   | Min | Max  |      |        |     |   |
| <b>AC4</b>  | 900 | 1260 |      |        | 142 | 9   |
| <b>AC5</b>  |     |      | 1000 | 1 3/8" | 168 | 12  |
| <b>AC6</b>  |     | 1400 |      |        |     | 14  |
| <b>AC7</b>  |     | 1370 |      |        |     | 17  |
| <b>AC8</b>  |     |      |      |        |     | 19  |
| <b>AC9</b>  |     | 1300 |      | 1 3/4" | 192 | 29  |

Angolo max. di lavoro: 15°  
Max working angle: 15°  
Angle de travail max.: 15°

**Le pompe Caprari utilizzano vernici certificate WRAS.**  
*Caprari pumps are coated with WRAS Approved paint*  
Les pompes Caprari utilisent des peintures certifiées WRAS.

**caprari**

**La CAPRARI S.p.A. si riserva facoltà di apportare modifiche atte a migliorare i propri prodotti in qualsiasi momento e senza preavviso alcuno**

*CAPRARI S.p.A. reserves the right to make changes to improve its products at any time and without any notice*

La Société CAPRARI S.p.A. se réserve la faculté d'apporter, à tout moment et sans aucun préavis, toute modification susceptible d'améliorer ses propres produits