

caprari

PMA

NEW SIZES
PMA65 | PMA125

**HIGH PRESSURE
MULTISTAGE
HORIZONTAL PUMPS**

**AXIAL
SUCTION**

Sizes from-to	DNm 65 DNm 125
Flow Rate up to	110 l/s
Head up to	1000 m
Suction port	PN40
Delivery port	PN40 (PMA) PN63 (PMAS) PN100 (PMAH)
Rotation speed (rpm)	1.450 - 3.500

IDEAL FOR

SNOWMAKING

WATER SUPPLY

INDUSTRIAL APPLICATIONS

FIRE-FIGHTING

IRRIGATION

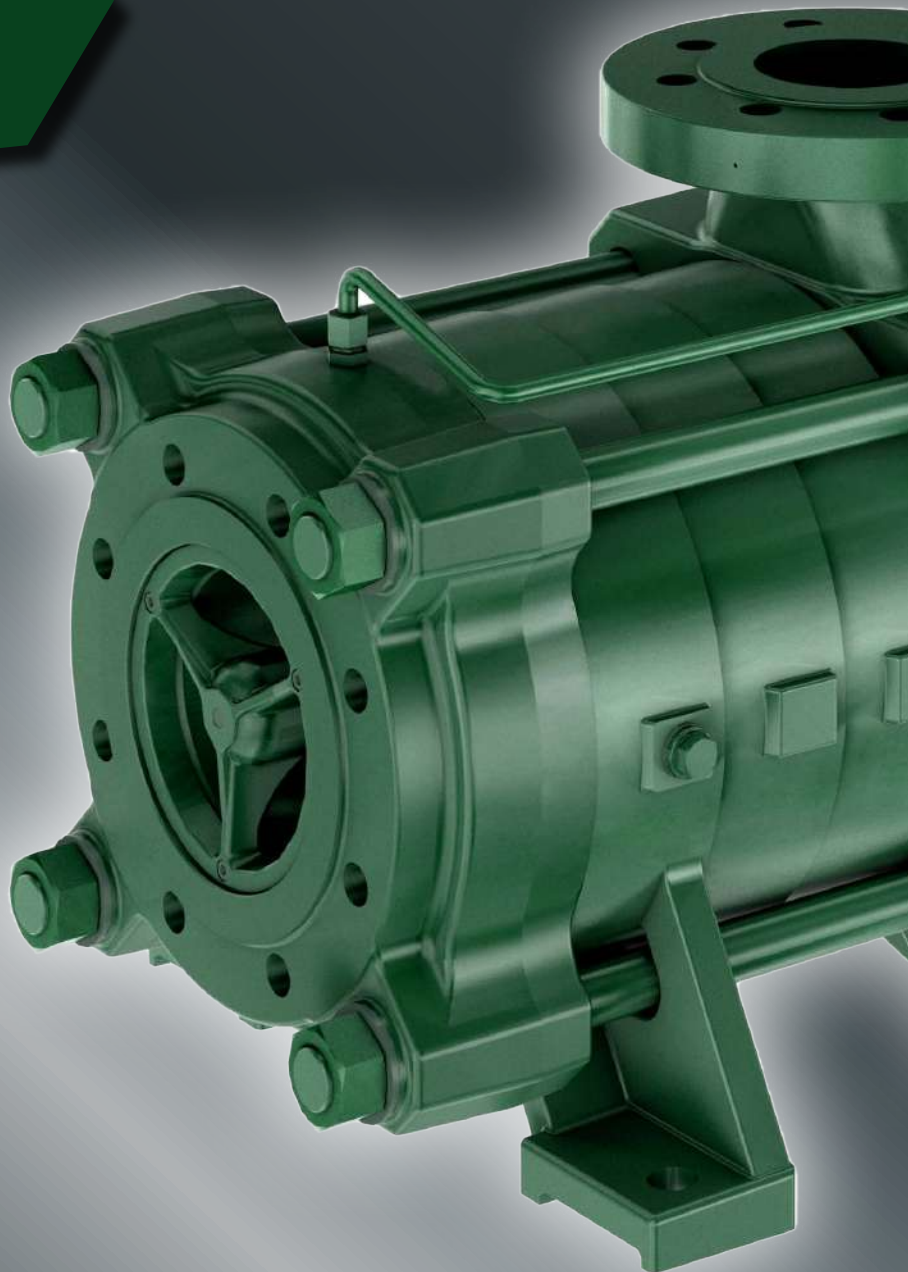

PMA65

PMA125

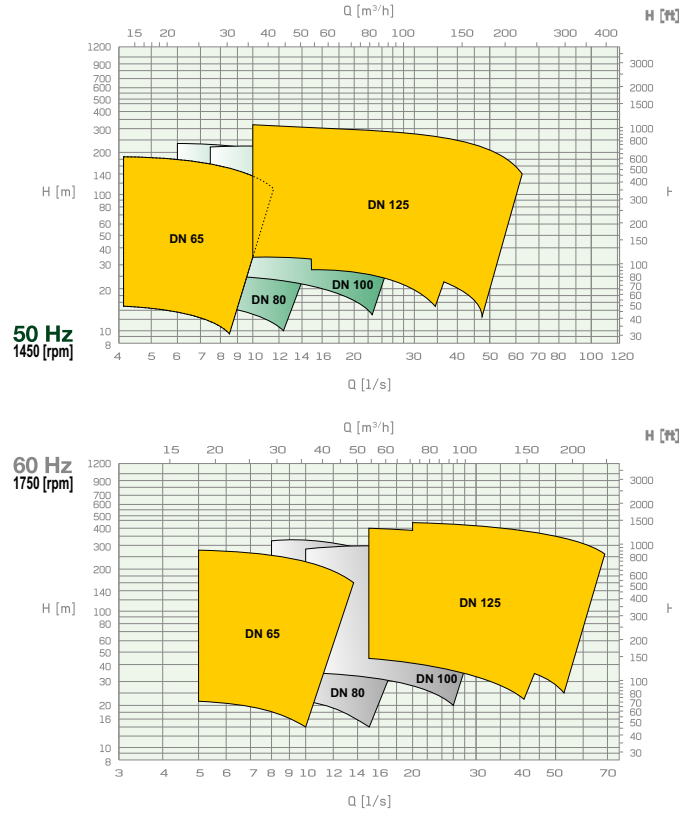
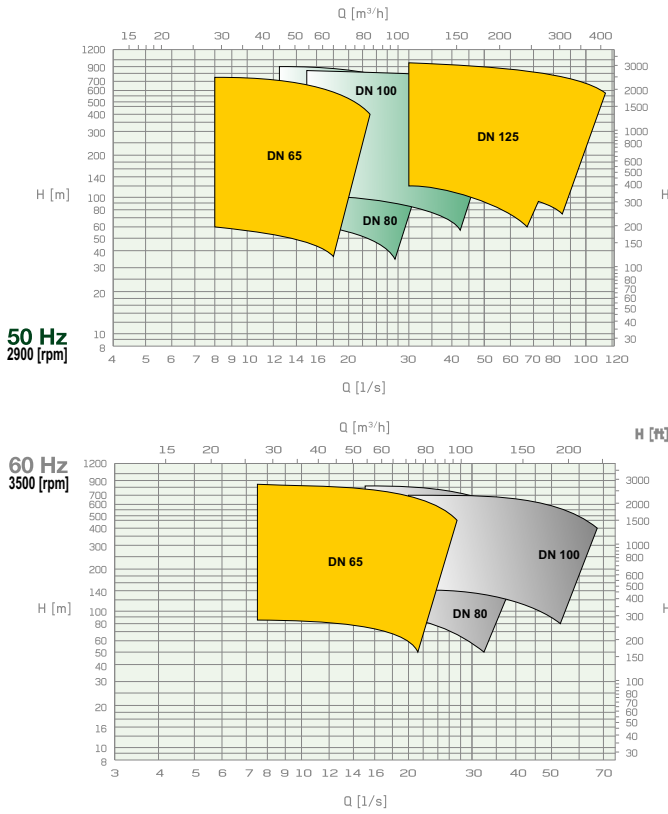

WHY CHOOSE PMA?

1 PRESSURE UP TO 100 BAR

- Impellers with **axial thrust compensation** system
- **High thicknesses** of the casting components and **high performance materials**

2 HIGH ENERGY SAVING

- **High-efficiency hydraulics:** best in class efficiency
- **Performance guaranteed over time:** replaceable wear rings

3 REDUCED INSTALLATION COSTS

- **Simple installation:** suction casing axial to the pipeline
- **Easy pump-motor alignment:** innovative baseframes

4 LOW NPSH VALUES

- **Reduces the risk of cavitation**
- **Reliable operation** even in lifting installations

5 EASY MAINTENANCE

- **Reduced maintenance:** grease lubricated bearing on the delivery side
- **Quick replacement** of the sleeve and bushing from the suction side

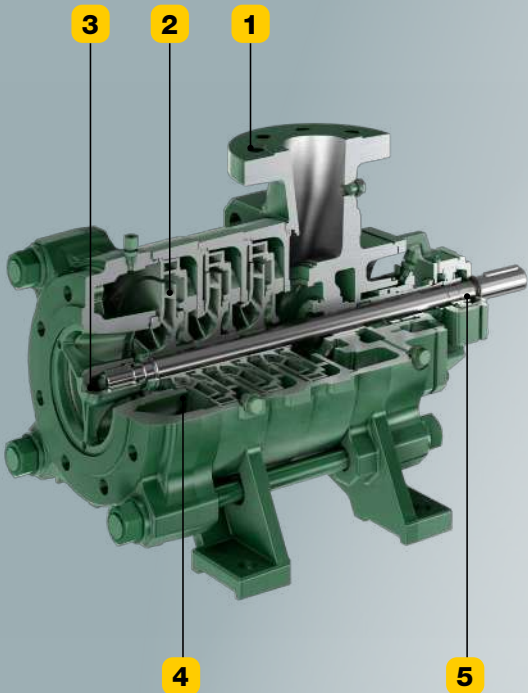

Now available for order

caprari

Follow us

