

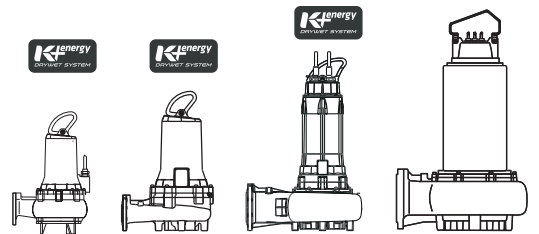

ELECTRIC SUBMERSIBLE SEWAGE PUMPS
*ELECTROPOMPES SUBMERSIBLES POUR
LIQUIDES CHARGEES*
ELETTROPOMPE SOMMERSIBILI PER
LIQUIDI CARICHI

non stop **K⁺**
50 Hz



caprari

pumping power

ISO 9001
ISO 14001
ISO 45001
BUREAU VERITAS
Certification



Introduction - Uses; <i>Présentation - Domaine d'emploi</i> ; Presentazione - Impieghi	3
Uses - Performances range; <i>Domaine d'emploi - Champs des performances</i> ; Impieghi - Campo di prestazioni	4
Mechanical features; <i>Caractéristiques mécaniques</i> ; Caratteristiche meccaniche	5
Hydraulic specifications; <i>Caractéristiques hydrauliques</i> ; Tipologie idrauliche	6
Possible installations; <i>Versions possibles</i> ; Installazioni possibili	7
Technical and operational features; <i>Caractéristiques techniques et de fonctionnement</i> ; Caratteristiche tecniche e di funzionamento ;	8

DN 65 (*N/X)

KCW065F - KCM065F - KCA065H - KCM065H - KCA065F

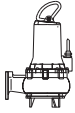

Performances range - <i>Champs de performances</i> - Campi di prestazione	9
Electric pump coding- <i>Exemplification du sigle de l'électropompe</i> - Esemplificazione sigla elettropompa	10
Construction and materials - <i>Construction et matériaux</i> - Costruzione e materiali	11
Technical features, dimensions and weights - <i>Caractéristiques de fonctionnement, dimensions et poids</i> - Caratteristiche di funzionamento, dimensioni e pesi	15
Accessories - <i>Accessoires</i> - Accessori	27
50 Hz motors features - <i>Caractéristiques des moteurs à 50 Hz</i> - Caratteristiche motori a 50 Hz	29

DN 80÷200 (*N/X)

KCW080H - KCW080L - KCW100H - KCW100L - KCM080F - KCM080H - KCM080L - KCM100H - KCM150H - KCM150L - KCD200N+00756.6P - KCA080H - KCA080L - KCA100H - KCA100L - KCA150H

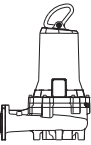

Performances range - <i>Champs de performances</i> - Campi di prestazione	30
Electric pump coding- <i>Exemplification du sigle de l'électropompe</i> - Esemplificazione sigla elettropompa	31
Construction and materials - <i>Construction et matériaux</i> - Costruzione e materiali	32
Technical features, dimensions and weights - <i>Caractéristiques de fonctionnement, dimensions et poids</i> - Caratteristiche di funzionamento, dimensioni e pesi	35
Accessories - <i>Accessoires</i> - Accessori	81
50 Hz motors features - <i>Caractéristiques des moteurs à 50 Hz</i> - Caratteristiche motori a 50 Hz	83

DN 100÷250 (*N/X)

KCW100N - KCM100N - KCM150N - KCM200P - KCD200N+01106.6P - KCD200N(4)P - KCD250P - KCA100N - KCA150N - KCA200N

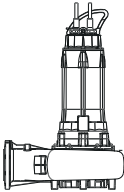

Performances range - <i>Champs de performances</i> - Campi di prestazione	84
Electric pump coding- <i>Exemplification du sigle de l'électropompe</i> - Esemplificazione sigla elettropompa	85
Construction and materials - <i>Construction et matériaux</i> - Costruzione e materiali	86
Technical features, dimensions and weights - <i>Caractéristiques de fonctionnement, dimensions et poids</i> - Caratteristiche di funzionamento, dimensioni e pesi	89
Accessories - <i>Accessoires</i> - Accessori	113
50 Hz motors features - <i>Caractéristiques des moteurs à 50 Hz</i> - Caratteristiche motori a 50 Hz	115

DN 150÷350 (*N)

KCM150R - KCM250R - KCM250Z - KCD300R - KCD300Z - KCD350R

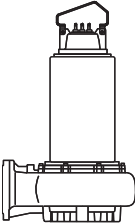

Performances range - <i>Champs de performances</i> - Campi di prestazione	116
Electric pump coding- <i>Exemplification du sigle de l'électropompe</i> - Esemplificazione sigla elettropompa	117
Construction and materials - <i>Construction et matériaux</i> - Costruzione e materiali	118
Technical features, dimensions and weights - <i>Caractéristiques de fonctionnement, dimensions et poids</i> - Caratteristiche di funzionamento, dimensioni e pesi	121
Accessories - <i>Accessoires</i> - Accessori	139
50 Hz motors features - <i>Caractéristiques des moteurs à 50 Hz</i> - Caratteristiche motori a 50 Hz	141

DN 150÷350 (*X)

KCM150R - KCM250R - KCM250Z - KCD300R - KCD300Z - KCD350R

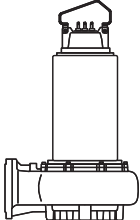

Performances range - <i>Champs de performances</i> - Campi di prestazione	142
Electric pump coding- <i>Exemplification du sigle de l'électropompe</i> - Esemplificazione sigla elettropompa	143
Construction and materials - <i>Construction et matériaux</i> - Costruzione e materiali	144
Technical features, dimensions and weights - <i>Caractéristiques de fonctionnement, dimensions et poids</i> - Caratteristiche di funzionamento, dimensioni e pesi	145
Accessories - <i>Accessoires</i> - Accessori	157
50 Hz motors features - <i>Caractéristiques des moteurs à 50 Hz</i> - Caratteristiche motori a 50 Hz	159

DN 250÷500

KCM250T - KCD300T - KCD350T - KCD400U - KCD500V

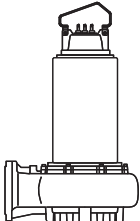

Performances range - <i>Champs de performances</i> - Campi di prestazione	160
Electric pump coding- <i>Exemplification du sigle de l'électropompe</i> - Esemplificazione sigla elettropompa	161
Construction and materials - <i>Construction et matériaux</i> - Costruzione e materiali	162
Technical features, dimensions and weights - <i>Caractéristiques de fonctionnement, dimensions et poids</i> - Caratteristiche di funzionamento, dimensioni e pesi	165
Accessories - <i>Accessoires</i> - Accessori	175
50 Hz motors features - <i>Caractéristiques des moteurs à 50 Hz</i> - Caratteristiche motori a 50 Hz	177

Flanges (UNI EN 1092-2) - <i>Brides (UNI EN 1092-2)</i> - Flange (UNI EN 1092-2)	178
---	-----

*N = Standard version - *N = Version standard - *N = Versione standard
 *X = Explosion-proof version - *X = Version antidéflagrante - *X = Versione antideflagrante
 See "Pump coding" - Voir "Identification du sigle" - Vedi "Esemplificazione sigla"

The electric submersible sewage pumps have been specially designed to operate submerged in the pumped fluid.

The hydraulic section is close coupled to the electric motor making the pumping unit compact, easy to install and reliable in operation. It is for this reason that the use of such pumps has become popular over the past few years for most applications involving sewage pumping.

The pumps are essential in depuration systems and are widely used in the sewage handling facilities of industry and local communities.

The K+ series electric pumps are designed to pump sewage containing gas, compacted solids and long fibrous material. The pumps can be supplied for fixed or submersible installation with base frame, and the design has paid particular attention to achieving a good overall efficiency to ensure that the pumps are as cheap as possible to run.

Les électropompes submersibles pour liquides chargés sont conçues spécialement pour travailler "immergées" dans le liquide à relever. La partie hydraulique est couplée directement au moteur électrique; c'est justement cette compacité de construction qui les rend faciles à installer et fiables pendant leur fonctionnement. Ces caractéristiques ont permis d'étendre leur emploi, au cours de ces dernières années, à tous les cas nécessitant le relevage des liquides chargés.

Ce sont des composants essentiels et très répandus dans les installations d'épuration, utilisés aussi dans les installations de services, les industries et les installations des collectivités locales. Les électropompes de la série K+ ont été étudiées pour véhiculer des eaux usées contenant des gaz et des corps solides compacts ou à fibres longues.

Elles sont aussi bien prévues pour installations fixes que submersible avec chassis de soutien. Une attention particulière a été portée aux rendements hydrauliques afin d'obtenir un maximum d'économie à l'utilisation.

Le elettropompe sommergibili per liquidi carichi sono appositamente studiate per funzionare immerse nel liquido da sollevare.

La parte idraulica è strettamente connessa al motore elettrico e proprio questa particolare compattezza costruttiva le rende di facile installazione e di sicuro funzionamento.

Per queste ragioni il loro impiego negli ultimi anni si è ampiamente diffuso in tutti quei casi in cui si debbano sollevare liquidi carichi.

Componenti essenziali e diffusissimi negli impianti di depurazione vengono utilizzate anche nei servizi, nelle industrie e negli impianti civili di comunità.

Le elettropompe della serie K+ sono state progettate per il convogliamento di acque di scarico, contenenti gas e corpi solidi compatti oppure a fibra lunga.

Sono previste sia per installazione fissa che per installazione immersa su telaio. Particolare attenzione è stata rivolta ai rendimenti delle macchine per ottenere la massima economia d'esercizio.

Uses Domaine d'emploi Impieghi

Thanks to their tough construction, series K+ electric pumps can be used to pump a variety of fluids amongst which are:

- clean and drinking water;
- untreated water,
- rain water;
- mixed water;
- sewage with solids and fibres;
- activated sludges;
- the recirculated sludges of digesters;
- industrial sludge;
- dirty abrasive water.

The permissible percentage of dry matter and the size and nature of the solids, the degree of aggressiveness and/or abrasiveness of the water are parameters often bound to the particular pump hydraulics or the physical dimensions.

A sewage pump must therefore be chosen according to the hydraulics and constructional features and materials of the pump itself.

Always consult our technicians for heavy duty uses or use beyond the specifications indicated in this catalogue.

Les électropompes K+, grâce à leur construction solide, peuvent être utilisées pour le relevage de différents liquides et en particulier:

- eaux claires et potables;
- eaux brutes;
- eaux pluviales;
- eaux mixtes;
- eaux résiduaires avec des corps solides et fibres;
- boues activées;
- boues de circulation des digesteurs;
- boues industrielles;
- eaux chargées abrasives.

Le pourcentage de matière sèche admissible, de même que la dimension et la nature des solides et le degré d'agressivité ou d'abrasion des eaux sont des paramètres liés au système hydraulique de la pompe et à son dimensionnement.

Il faut donc choisir une électropompe pour le relevage de liquide chargé en fonction des caractéristiques hydrauliques et des matériaux de construction.

Pour des emplois particuliers, hors des spécifications indiquées dans ce catalogue, veuillez consulter directement nos techniciens.

Le elettropompe K+ per la loro solida costruzione possono essere impiegate nel sollevamento di diversi liquidi fra i quali:

- acque pulite e potabili;
- acque grezze;
- acque piovane;
- acque miste;
- acque nere con solidi e fibre;
- fanghi attivi;
- fanghi di ricircolo dei digestori;
- fanghi industriali;
- acque cariche abrasive.

La percentuale di sostanza secca ammissibile, così come la dimensione e la natura dei solidi, il grado di aggressività e/o di abrasività delle acque, sono parametri spesso legati alla particolare idraulica della pompa o alle sue caratteristiche dimensionali.

La scelta di una elettropompa per il sollevamento di un liquido carico deve essere quindi fatta in base alle caratteristiche dell'idraulica e dei materiali costruttivi della pompa.

Per impieghi gravosi o comunque al di fuori delle specifiche date in questo catalogo consultare i nostri tecnici.

Uses
Domaine d'emploi
Impieghi

	ELECTRIC SIZE / DIMENSION ÉLECTRIQUE / GRANDEZZA ELETTRICA									
	F	H	L	N	P	R	Z	T	U	V
ELECTRIC POWER [kW] / PUISSANCE ÉLECTRIQUE [kW] / POTENZA ELETTRICA [kW]	1,6÷2,1	1,5÷6,5	6,5÷16,5	11÷35	11÷19,5	21÷82	17÷21	60÷180	145÷260	145÷345
DRYWET SYSTEM VERTICAL INSTALLATION / SYSTÈME VERTICAL DRYWET / DRYWET SYSTEM IN VERTICALE		●	●	●	●	●	○			
DRYWET SYSTEM HORIZONTAL INSTALLATION / SYSTÈME HORIZONTAL DRYWET / DRYWET SYSTEM IN ORIZZONTALE		●	●							
FIXING SYSTEM / FIXING SYSTEM / FIXING SYSTEM		●	●	●						
CONDUCTIVITY PROBE IN OIL CHAMBER / SONDES DE CONDUCTIVITE DANS CHAMBRE A HUILE / SONDA DI CONDUITTIVITÀ NELLA CAMERA A OLIO	○	●	●	●	●	●	●	●	●	●
IE3 ELECTRICAL EFFICIENCY CLASS / CLASSE D'EFFICACITÉ ÉLECTRIQUE IE3 / CLASSE DI EFFICIENZA ELETTRICA IE3	●	●	●	●	●	●	○	○	○	○
H CLASS ELECTRICAL INSULATION / ISOLEMENT CLASSE H / ISOLAMENTO ELETTRICO CLASSE H	●	●	●	●	●	●	○	○	○	○
REMOVABLE PLUG CONNECTOR / BOUCHON AMOVIBLE / SPINOTTO RIMOVIBILE		●	●	●	●					
CABLE CLAMP / PRESSE-ÉTOUPE / PRESSACAVO	●					●	●	●	●	●
DOUBLE MECHANICAL SEAL / DOUBLE GARNITURE MÉCANIQUE / DOPPIA TENUTA MECCANICA	●	●	●	●	●	●	●	●	●	●

● Standard / Standard / Standard
○ Optional / Optionnel / Opzionale

Performances range
Champs des performances
Campo di prestazioni

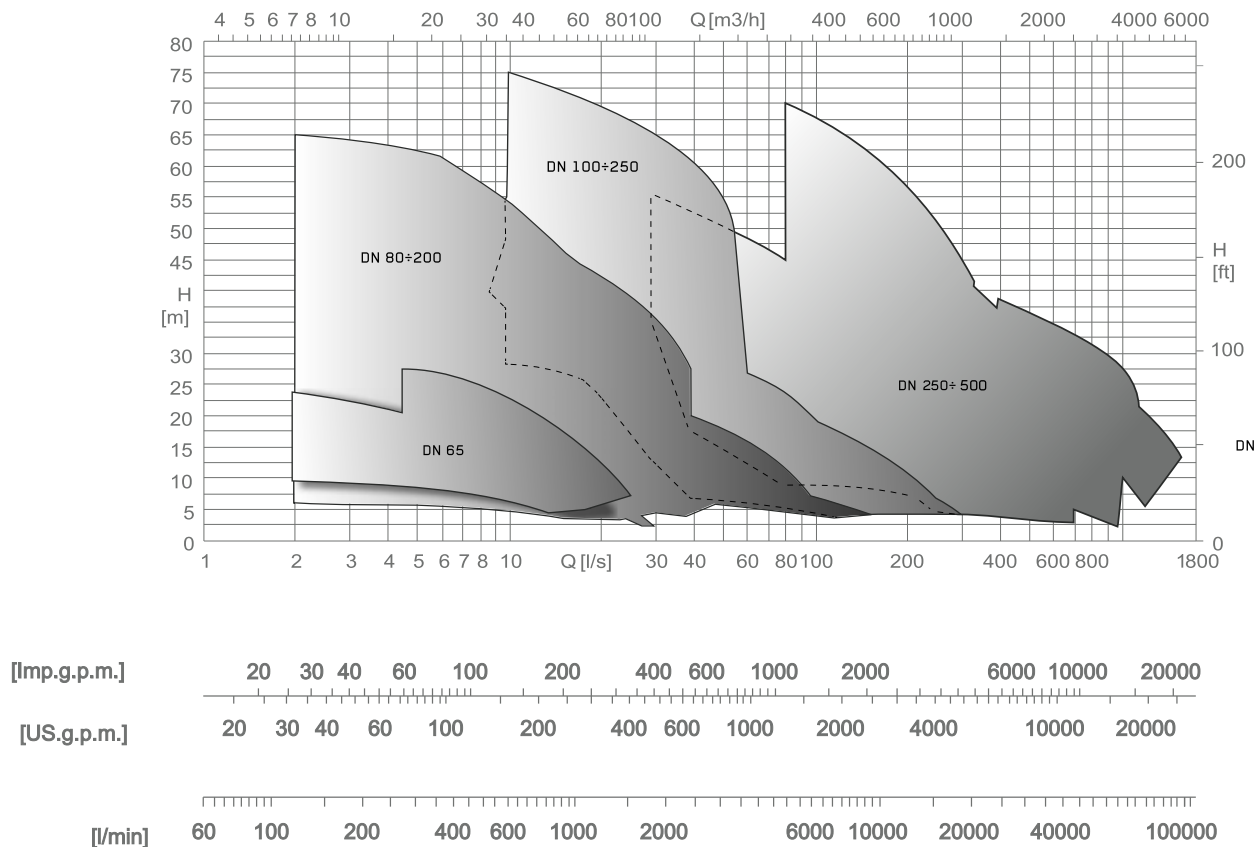

MOTOR

Asynchronous, three-phase with squirrel-cage rotor. The motor is cooled by the fluid in which it is submerged or by a forced cooling system. The motor is separated from the pump by a large chamber partially filled with oil that acts as a lubricant for the mechanical seals and as a heat exchanger. Ensure compliance with the minimum head value given with the dimensions of each individual electric pump in order to ensure that the motor is correctly cooled, the exception being made for motors with forced cooling.

SUPPORTS

The shaft of the motor, on the extension of which the impeller is mounted, is guided by two bearings pre-lubricated with grease; the lower one supports the axial thrust. The rotating assembly is very compact, with a short overhung pump shaft which reduces bearing loads and ensures reliability and long life.

MECHANICAL SEALS

The double mechanical seal (mounted in series) is a dual guarantee safeguarding the electric motor. If the seal on the pump side becomes faulty, the motor will not be damaged thanks to the second seal on the motor side. These seals are made of particularly suitable materials able to withstand heavy-duty conditions; the pump side seal is made with abrasionproof materials.

SAFE OPERATION

- The conductivity sensor in the oil chamber warns if there is water and transmits the relative signal to the appropriately preset electric panel. This checks that the mechanical seals on the pump side operate correctly.
- The motor is equipped with thermal probes connected in series in the stator winding; should over-temperature conditions occur, the probes automatically cut off the power.

MOTEUR

Asynchrone, triphasé, rotor à cage d'écureuil. Le refroidissement est réalisé par le liquide dans lequel il est immergé ou forcé. Le moteur est séparé du corps de la pompe par une large chambre remplie partiellement d'huile pour la lubrification des garnitures d'étanchéité et de refroidissement. Exception faite pour les moteurs à refroidissement forcé, pour permettre un refroidissement correct du moteur il faut respecter la cote de la charge d'eau minimum, indiquée dans les plans d'encombrement de chaque électropompe.

PALIERES

L'arbre moteur sur lequel est monté directement la roue, est guidé par deux roulements lubrifiés à la graisse; dont l'inférieur est dimensionné pour supporter la poussée axiale. La compacité particulière de l'électropompe permet la réduction du porte-à-faux de l'arbre et, par conséquent, la charge sur les roulements au bénéfice de la fiabilité et de la longévité.

GARNITURES MECANIKES

La double garniture mécanique (montée de série) est une double garantie pour le moteur électrique. En cas de rupture de la garniture côté pompe, le moteur ne subit aucun dommage grâce à la présence de la garniture côté moteur. Elles sont en matériaux particulièrement adaptés aux conditions d'utilisation difficiles; la garniture côté pompe est résistante aux particules abrasives.

SECURITE DE FONCTIONNEMENT

- *La sonde de conductivité présente dans la chambre à huile, signale la présence d'eau et le signale au coffret électrique prédisposé à cet effet. Elle sert à vérifier le bon fonctionnement des garnitures mécaniques.*
- *Le moteur est doté de sondes thermiques montées en série et incorporées dans l'enroulement du stator; en cas de surchauffe de l'enroulement, elles interviennent en coupant l'alimentation.*

MOTORE

Asincrono, trifase, con rotore a gabbia di scoiattolo. Il raffreddamento è effettuato dallo stesso liquido in cui è immerso o da raffreddamento forzato. Il motore è separato dal corpo pompa da un'ampia camera parzialmente riempita d'olio che funge da lubrificante per le tenute meccaniche e da scambiatore di calore. Esclusi quelli con raffreddamento forzato, per consentire il corretto raffreddamento del motore occorre osservare la quota di minimo battente indicata nelle dimensioni di ogni singola elettropompa.

SUPPORTAZIONE

L'albero del motore, sul cui prolungamento è montata la girante, è guidato da due cuscinetti lubrificati a grasso; quello inferiore è dimensionato per la supportazione della spinta assiale. La particolare compattezza dell'elettropompa consente il contenimento della lunghezza dell'albero a sbalzo e, di conseguenza, il carico sui cuscinetti a beneficio dell'affidabilità e durata.

TENUTE MECCANICHE

La doppia tenuta meccanica (montate in serie) è una doppia garanzia di salvaguardia del motore elettrico. Nel caso di avaria della tenuta lato pompa il motore non subisce danni grazie alla presenza della tenuta lato motore. Esse sono di materiali adatti per condizioni di impiego gravose; quella lato pompa è realizzata con materiali resistenti all'abrasione.

SICUREZZA DI FUNZIONAMENTO

- Il sensore di conduttività presente nella camera olio, avverte della presenza d'acqua e lo segnala al quadro elettrico adeguatamente predisposto. Esso serve a verificare il corretto funzionamento delle tenute meccaniche.
- Il motore ha delle sonde termiche collegate in serie inserite nell'avvolgimento statorico. In caso di sovratemperatura, esse interrompono il circuito di alimentazione.

The hydraulic part consists of the impeller and pump casing. Two mechanical seals installed in series protect against ingress from the pump casing to the motor chamber.





Electric pumps of the K+ series feature three different hydraulics with the following characteristics.

La partie hydraulique est constituée d'une roue et d'un corps de pompe. L'étanchéité entre le corps de pompe et la chambre moteur est garantie par le montage de deux garnitures mécaniques montées de série.

Dans les électropompes de la série K+ sont montés trois différents systèmes hydrauliques ayant les caractéristiques suivantes.

La parte idraulica è costituita da girante e corpo pompa. Lo sbarramento contro le infiltrazioni dal corpo pompa alla camera motore è garantito da due tenute meccaniche montate in serie.

Nelle elettropompe della serie K+ vengono montate tre diverse idrauliche con le seguenti caratteristiche.

	<p>RETRACTED OPEN IMPELLER: W The impeller offers reliability against clogging due to the feature of wide through passages, and a good resistance to wear thanks to the absence of shimming. The versatility of use compensates for this impellers somewhat lower efficiency. The impeller can be reduced in dimension to offer different characteristics. For water containing a large amount of solids and long fibre, sewage with a high gas and sludge content.</p> <p>ROUE VORTEX: TYPE W <i>Caractérisée par une bonne résistance contre le colmatage, larges sections de passages sphériques, bonne robustesse à l'usure due à l'absence de canaux, rendements limités compensés par la polyvalence d'emploi, possibilité de rognage des roues.</i> <i>Appropriée pour le relevage d'eaux ayant une concentration élevée de corps solides et à fibres longues, lisiers ayant une concentration élevée de gaz et de boues.</i></p> <p>GIRANTE APERTA ARRETRATA: W Caratterizzata da buona sicurezza contro l'intasamento, larghi passaggi sferici, buona resistenza all'usura, anche grazie all'assenza di rasamenti, versatilità d'impiego che compensa i rendimenti contenuti, possibilità di ridurre le giranti. Indicata per il sollevamento di acque con elevato contenuto di corpi solidi e a fibra lunga, liquami con alto contenuto di gas e fanghi.</p>	<p>SINGLE-CHANNEL IMPELLER: M It offers reliability against clogging and features wide through sections and a good resistance to wear, low mechanical action on the fluid, high hydraulic efficiency. Particularly suitable for clean water, water containing solid and fibrous solids, cloacal water, sewage and sludge. Low vibrations thanks to the dynamically balanced impeller.</p> <p>ROUE MONOCANAL: TYPE M <i>Caractérisée par une bonne résistance contre le colmatage; larges sections de passages sphériques; bonne robustesse à l'usure; faible contrainte mécanique sur le fluide; rendement hydraulique élevé.</i> <i>Particulièrement adaptée pour les eaux claires, les eaux chargées contenant des corps solides et des fibre, les eaux résiduelles, les boues résultant du traitement des eaux.</i> <i>Basses vibrations grâce à la roue équilibrée dynamiquement.</i></p> <p>GIRANTE MONOCANALE: M Caratterizzata da buona sicurezza contro l'intasamento, larghi passaggi sferici, buona resistenza all'usura, bassa azione meccanica sul fluido, elevato rendimento idraulico. Particolarmente adatta per acque chiare, acque cariche contenenti corpi solidi e fibrosi, acque cloacali, liquami e fanghi. Basse vibrazioni grazie alla girante equilibrata dinamicamente.</p>	
	<p>DOUBLE CHANNEL IMPELLER: D It offers reliability against clogging and features wide through sections and a good resistance to wear, low mechanical action on the fluid, high hydraulic efficiency at high flow rates. Particularly suitable for clean water, water containing solids and fibrous solids, cloacal water, sewage and sludge. Low vibrations thanks to the dynamically balanced impeller.</p> <p>ROUE A 2 CANAUX: D <i>Caractérisée par une bonne sécurité contre le bourrage, passages sphériques larges, bonne résistance à l'usure, faible action mécanique sur le fluide, haute performance hydraulique aux débits élevés.</i> <i>Tout particulièrement indiquée pour les eaux claires, eaux chargées contenant des corps solides et fibreux, eaux d'égout, lisiers et boues. Basses vibrations grâce à la roue équilibrée dynamiquement.</i></p> <p>GIRANTE BICANALE: D Caratterizzata da buona sicurezza contro l'intasamento, larghi passaggi sferici, buona resistenza all'usura, bassa azione meccanica sul fluido, elevato rendimento idraulico alle alte portate. Particolarmente adatta per acque chiare, acque cariche contenenti corpi solidi e fibrosi, acque cloacali, liquami e fanghi. Basse vibrazioni grazie alla girante equilibrata dinamicamente.</p>	<p>OPEN TWIN BLADE IMPELLER: A It offers reliability against clogging and features a good resistance to wear, low mechanical action on the fluid, high hydraulic efficiency. Particularly suitable for clean water, water containing solid and fibrous solids, cloacal water, sewage and sludge. Low vibrations thanks to the dynamically balanced impeller.</p> <p>ROUE OUVERT À DEUX AUBES: A <i>Caractérisée par une bonne résistance contre le colmatage; bonne robustesse à l'usure; faible contrainte mécanique sur le fluide; rendement hydraulique élevé.</i> <i>Particulièrement adaptée pour les eaux claires, les eaux chargées contenant des corps solides et des fibre, les eaux résiduelles, les boues résultant du traitement des eaux.</i> <i>Basses vibrations grâce à la roue équilibrée dynamiquement.</i></p> <p>GIRANTE BIPALA APERTA: A Caratterizzata da buona sicurezza contro l'intasamento, buona resistenza all'usura, bassa azione meccanica sul fluido, elevato rendimento idraulico. Particolarmente adatta per acque chiare, acque cariche contenenti corpi solidi e fibrosi, acque cloacali, liquami e fanghi. Basse vibrazioni grazie alla girante equilibrata dinamicamente.</p>	

 Caprari's **non stop K+** is the new series of electric pumps for wastewater designed with non-clogging hydraulic parts and generously sized free passages able to do away with down times and costly maintenance work.

 Caprari **non stop K+** est la nouvelle série d'électropompes pour eaux usées projetée

 Caprari **non stop K+** è la nuova serie di elettropompe per liquidi carichi progettata con idraulica non intasabile e ampi passaggi liberi così da evitare fermi macchina e costosi interventi di manutenzione.

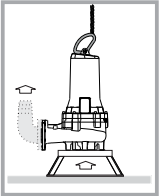
<p>FIXED WITH CONNECTING FOOT This is the most suitable installation for permanent pumping stations. No particular building structures are required and the system is easy to construct. Quick connection ensures that the pump can be rapidly and easily removed from the tank and successively reinstalled. This means that routine or extraordinary maintenance work can be carried out in complete safety without the need to enter the accumulation tank. For this installation are available the connecting foot, the guide pipes, chain, etc.</p> <p>FIXE AVEC BASE D'ACCOUPEMENT <i>C'est l'installation la mieux adaptée aux stations de relevage fixes. Aucune structure particulière de génie civil n'est nécessaire et la réalisation est facile. L'accouplement rapide permet de relever avec facilité l'électropompe de la cuve, d'effectuer l'entretien ordinaire ou l'intervention exceptionnelle, en toute sécurité et de la réinstaller sans devoir entrer dans la fosse. Pour cette installation sont disponibles sur demande le pied d'accouplement, barres de guidage, chaîne, etc.</i></p> <p>FISSA CON PIEDE DI ACCOPIAMENTO E' l'installazione più indicata per le stazioni di sollevamento fisse. Non sono richieste particolari infrastrutture edili e l'impianto è di facile realizzazione. L'accoppiamento rapido consente una veloce e facile estrazione e successivo riposizionamento dell'elettropompa nella vasca permettendo di eseguire l'ordinaria manutenzione o l'intervento eccezionale in tutta sicurezza senza dovere entrare nella vasca di raccolta. Per questa installazione sono disponibili il piede di accoppiamento, tubi guida, catena ecc.</p>	
<p>SUBMERSIBLE WITH BASE FRAME Recommended version provided for electric pumps installed on flat/solid surfaces and with flexible discharge hose only, particularly suitable for: - all infrequent or non-routine uses; - use on building sites or where mobile systems are required; - remodelling of existing stations with architectural constraints. Support frame, delivery hose pipe holder, chain, etc. available on demand.</p> <p>IMMERGEE AVEC CHASSIS DE SOUTIEN <i>Version conseillée à condition que l'électropompe soit installée sur surface d'appui solide et plate et avec tuyauterie de refoulement flexible, particulièrement indiquée pour:</i> <i>-tous emplois occasionnels ou exceptionnels</i> <i>-emplois sur chantier ou sites mobiles</i> <i>-restructuration de stations existantes ayant des contraintes de génie civil. Sur demande sont disponibles le châssis de soutien, coude de refoulement pour tuyau flexible, chaîne, etc.</i></p> <p>IMMERSA SU TELAIO Versione consigliata solo con elettropompa installata su superficie di appoggio solida e piana e con tubazione di mandata flessibile, particolarmente indicata per: - tutti gli impieghi saltuari o che hanno carattere di eccezionalità - impiego in cantiere o dove sia richiesta la mobilità - ristrutturazione di stazioni esistenti con vincoli architettonici. Sono fornibili il telaio di sostegno, curva porta tubo di mandata flessibile, catena ecc..</p>	
<p>IN A DRY CHAMBER This is the horizontal or vertical installation requiring a dry chamber beside the fluid accumulation tank in order to house the electric pump unit. As compared to conventional non-submersible machines, this installation offers the utmost reliability during operation and absence of risks even if the dry chamber becomes submerged with fluid. Base frames available on demand.</p> <p>EN FOSSE SECHE <i>L'installation horizontale ou verticale requiert une fosse sèche, adjacente à la cuve de récupération du liquide, pour loger le groupe électropompe. Par rapport aux machines traditionnelles non submersibles, le fonctionnement est parfaitement sûr et sans risques même dans le cas où la fosse est submergée par le liquide. Sur demande sont disponibles les supports de soutien.</i></p> <p>IN CAMERA ASCIUTTA E' l'installazione orizzontale o verticale che necessita di una camera asciutta, adiacente alla vasca di raccolta del liquido, per ospitare il gruppo elettropompa. Rispetto le macchine tradizionali non sommergibili presenta massima sicurezza di funzionamento ed assenza di rischi anche nella eventualità che la camera asciutta venga sommersa di liquido. Sono fornibili i supporti di sostegno.</p>	
<p>HORIZONTAL Upward outlet. The electric pump is fixed in place with support brackets. This keeps the need for special parts to the minimum. Horizontal intake, vertical delivery. Minimum height measurement.</p> <p>HORIZONTALE <i>Avec orifice de refoulement vers le haut. La fixation de l'électropompe est effectuée avec étriers de support. Cette disposition demande un minimum en pièces spéciales. L'aspiration est horizontale tandis que le refoulement est vertical; encombrements minimum en hauteur.</i></p> <p>ORIZZONTALE Con bocca premente rivolta verso l'alto. Il fissaggio della elettropompa viene eseguito con staffe di sostegno. Questa disposizione richiede un numero limitato di pezzi speciali. L'aspirazione è orizzontale e la mandata è verticale con un contenuto ingombro in altezza.</p>	
<p>VERTICAL Assembly allowing easy inspection and maintenance. Horizontal intake and delivery. This is the dry chamber installation that offers the smallest plan size.</p> <p>VERTICALE <i>Cette disposition demande une bonne facilité de visite et d'entretien, l'aspiration et le refoulement sont horizontaux; c'est l'installation qui est la moins encombrante.</i></p> <p>VERTICALE Questa disposizione consente la massima facilità di ispezione e manutenzione, l'aspirazione e la mandata sono orizzontali e presenta i minimi ingombri in pianta.</p>	

Technical and operational features
 Caractéristiques techniques et de fonctionnement
 Caratteristiche tecniche e di funzionamento

- Asynchronous, three-phase electric motor with squirrel-cage rotor, class F insulation (max. 155 °C) and class H insulation (max. 180 °C), submersible, with protection degree IP68 in compliance with IEC 529 standards or IP58 according to EN 60034-5 standards. Continuous or intermittent service.
- Tolerable voltage: 230 V ± 10%; 400 V ± 10%.
- Maximum power draw unbalance: 5%.
- Minimum submergence depth: consult data stated on each performance page.
- Maximum submergence depth: 20 m.
- Maximum temperature of pumped fluid: 40 °C.
- pH of raised fluid: 4 ÷ 10.
- The pumped fluid can contain solids in suspension, the size of which must not exceed the open section in the hydraulic part.
- Contact our technical department if the density of the pumped fluid exceeds 1 kg/dm³ and/or if the viscosity exceeds 1 mm²/s (1 cSt).
- If the percentage of dry matter in the fluid exceeds 4%, it will be necessary to consider the consequences of the variation in the specific weight and viscosity of the fluid.
- When the electric pump is installed in compliance with the instructions given in the use and maintenance instructions, the acoustic pressure level issued by the machine within the forecast operating field will never reach 70 dB(A). Noise measurement was conducted according to ISO 3746 and the gauging points complied with EU directive 98/37. The maximum value is evenly distributed around the product.
- Construction of electric pump models in the explosion-proof version (X) complies with standards EN60079-0 - EN60079-1 type ATEX II 2G Ex db h IIB T4 Gb (models in electrical size F, H, L, N, P, R, Z) and I M2 Ex db h I Mb (models in electrical size F, H, L, N, P).
- Rotation direction: Clockwise viewed from above.

FORCED COOLING EXECUTION (..R VERSION)

Forced cooling on above models is obtained as follows:

- through the internal circulation of the pumped liquid itself. In such a case its temperature must not be higher than 40 °C and a low solid content;
- by feeding the system through an external source (Q_{min}=0,2 l/s at 4 bar max).

- *Moteur électrique submersible, asynchrone triphasé, avec rotor à cage d'écureuil, isolement classe F (155 °C maxi.) ou classe H (180 °C maxi.), degré de protection IP68 conformément aux normes IEC 529 ou bien IP58 conformément aux normes EN 60034-5, service continu ou intermittent.*
- *Variation de la tension d'alimentation: 230 V ± 10%; 400 V ± 10%.*
- *Déséquilibre maximum admis sur le courant absorbé: 5%.*
- *Profondeur d'immersion minimum: voir la cote indiquée sur chaque page des caractéristiques.*
- *Profondeur d'immersion maximum: 20 m.*
- *Température maxi. du liquide pompé: 40 °C.*
- *pH du liquide à relever: 4 à 10.*
- *Le liquide véhiculé peut contenir des corps solides en suspension dont la dimension ne dépasse pas le passage libre dans la partie hydraulique.*
- *En présence d'une densité supérieure à 1 kg/dm³ et/ou une viscosité supérieure à 1 mm²/s (1 cSt) consulter directement nos services techniques. Si le liquide à pomper contient un pourcentage de matière sèche de plus de 4%, il faut prendre en compte les conséquences provoquées par la variation du poids spécifique et de la viscosité du mélange liquide.*
- *Quand l'électropompe est installée selon les indications indiquées dans la notice d'utilisation et d'entretien, le niveau acoustique est inférieur à 70 dB(A). La mesure du bruit est contrôlée selon la ISO 3746 et les points de relevés selon la directive 98/37/CE. Les valeurs maximum sont uniformes autour de la machine.*
- *Pour les modèles d'électropompes en version antidéflagrantes (X), la construction est conforme à la norme EN60079-0 - EN60079-1, type ATEX II 2G Ex db h IIB T4 Gb (modèles en taille électrique F, H, L, N, P, R, Z) et I M2 Ex db h I Mb (modèles en taille électrique F, H, L, N, P).*
- *Rotation: dans le sens des aiguilles d'une montre vue du haut.*

EXECUTION AVEC REFROIDISSEMENT (VERSION ..R)

Sur ces modèles le refroidissement forcé est obtenu:

- *par la circulation intérieure du liquide pompé pourvu que sa température soit inférieure à 40 °C et un faible contenu de corps solides;*
- *par alimentation parmi une source extérieure (Q_{min}=0,2 l/s à 4 bar max) dans les autres conditions.*

- **Motore elettrico, asincrono trifase, con rotore a gabbia di scoiattolo, isolamento in classe F (155 °C max.) o in classe H (180 °C max.), sommersibile con grado di protezione IP68 secondo le norme IEC 529 o IP58 secondo le norme EN 60034-5, servizio continuo o intermittente.**
- **Variazione della tensione di alimentazione: 230 V ± 10%; 400 V ± 10%.**
- **Squilibrio massimo ammesso sulla corrente assorbita: 5%.**
- **Profondità di immersione minima: vedi quota indicata su ogni pagina caratteristica.**
- **Profondità di immersione massima: 20 m.**
- **Temperatura max. liquido pompato: 40 °C.**
- **pH del liquido da sollevare: 4 ÷ 10.**
- **Il liquido pompato può contenere corpi solidi in sospensione la cui grandezza non sia superiore al passaggio libero nella parte idraulica.**
- **Interpellare i nostri uffici tecnici in presenza di una densità superiore a 1 kg/dm³ e/o di una viscosità superiore a 1 mm²/s (1 cSt). Se si riscontra una percentuale secca del fluido superiore al 4% occorre considerare le conseguenze dovute alla variazione del peso specifico e della viscosità della miscela liquida.**
- **Quando l'elettropompa viene installata secondo le indicazioni fornite sul manuale di uso e manutenzione il livello di pressione acustica emesso dalla macchina nel campo di funzionamento previsto, non raggiunge in nessun caso i 70 dB(A). La misura del rumore è stata condotta secondo la ISO 3746 ed i punti di rilievo secondo la direttiva 98/37/CE. Il valore massimo si trova uniformemente distribuito attorno al prodotto.**
- **Per i modelli di elettropompe in versione antidéflagrante (X), la costruzione è conforme alle norme EN60079-0 - EN60079-1 tipo ATEX II 2G Ex db h IIB T4 Gb (modelli in grandezza elettrica F, H, L, N, P, R, Z) e I M2 Ex db h I Mb (modelli in grandezza elettrica F, H, L, N, P).**
- **Senso di rotazione: orario vista dall'alto.**

MACCHINE CON RAFFREDDAMENTO (VERSIONE ..R)

Su questi modelli il sistema di raffreddamento forzato è ottenuto:

- con la circolazione interna dello stesso liquido pompato purché la sua temperatura non superi i 40 °C. e con un basso contenuto di sostanze solide.
- alimentandolo tramite una fonte esterna (Q_{min}=0,2 l/s a 4 bar max) negli altri casi.

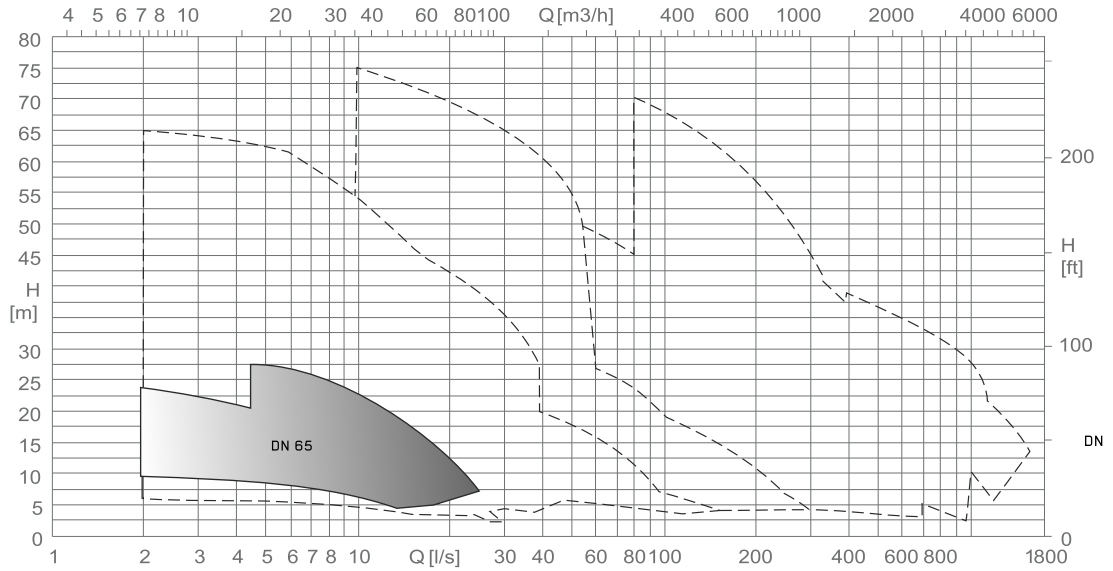

[Imp.g.p.m.]



[US.g.p.m.]



[l/min]



Construction and materials
Construction et matériaux
Costruzione e materiali

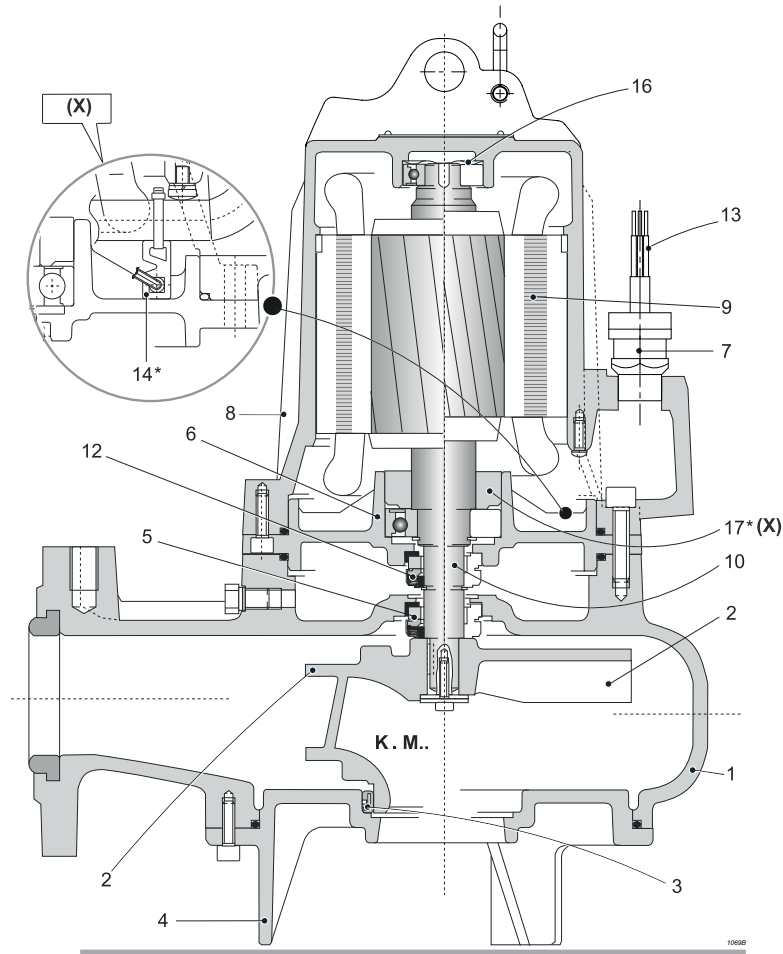

Pos.	Parts	Materials	Nomenclature	Matériaux	Nomenclatura	Materiale
1	Delivery body	Cast iron	Corps de refoulement	Fonte grise	Corpo mandata	Ghisa grigia
2	Impeller	Cast iron	Roue	Fonte grise	Girante	Ghisa grigia
3	Impeller wear ring	Steel/Rubber	Bague d'usure	Acier/Caoutchouc	Anello sede girante	Acciaio/Gomma
4	Suction support	Cast iron	Palier aspiration	Fonte grise	Supporto aspirazione	Ghisa grigia
5	Mechanical seal on pump side	silicon carbide/ceramic	Garniture mécanique côté pompe	carbure de silicium/céramique	Tenuta meccanica lato pompa	Carburo di silicio/ceramica
6	Support bearing	Nodular cast iron	Support de roulement	Fonte sphéroïdale	Supporto cuscinetto	Ghisa sferoidale
7	Cable clamp	Brass	Presse-étoupe	Laiton	Pressacavo	Ottone
8	Motor casing	Cast iron	Enveloppe du moteur	Fonte grise	Carcassa motore	Ghisa grigia
9	Stator	Electrical steel	Stator	Tôle magnétique	Statore	Lamierino magnetico
10	Complete shaft with rotor	Stainless steel/ Magnetic steel	Arbre avec rotor	Acier inox/Tôle magnétique	Albero completo di rotore	Acciaio inox/ Lamierino magnetico
12	Mechanical seal on motor side	Ceramic/graphite	Garniture mécanique côté moteur	Céramique/graphite	Tenuta meccanica lato motore	Ceramica/grafite
13	Round power cable	-	Câble rond d'alimentation	-	Cavo tondo di alimentazione	-
14*	Conductivity probe	-	Sondes de conductivité	-	Sonda di conduttività	-
16	Elastic ring	Stainless steel	Circlip	Acier inox	Anello elastico	Acciaio inox
17*	Spacer sleeve	Steel	Entretoise	Acier	Distanziale	Acciaio
18	Handle (upon request)	Stainless steel	Poignée (sur demande)	Acier inox	Maniglia (su richiesta)	Acciaio inox

* For explosion-proof versions (X);
On demand for (N) versions.
(Conductivity probe in the motor casing)
Screws and nuts in stainless steel.
Available version with AISI 316 stainless steel impeller.

* Pour version antidéflagrantes (X);
Sur demande pour les versions (N).
(Sonde de conductivité dans l'enveloppe du moteur)
Vis et écrous en acier inox
Disponible version Avec roue en acier inox AISI 316.

* Per versioni antideflagranti (X);
su richiesta per versioni (N).
(Sonda di conduttività nella carcassa motore)
Viti e dadi in acciaio inox
Disponibile versione con girante in acciaio inox AISI 316.

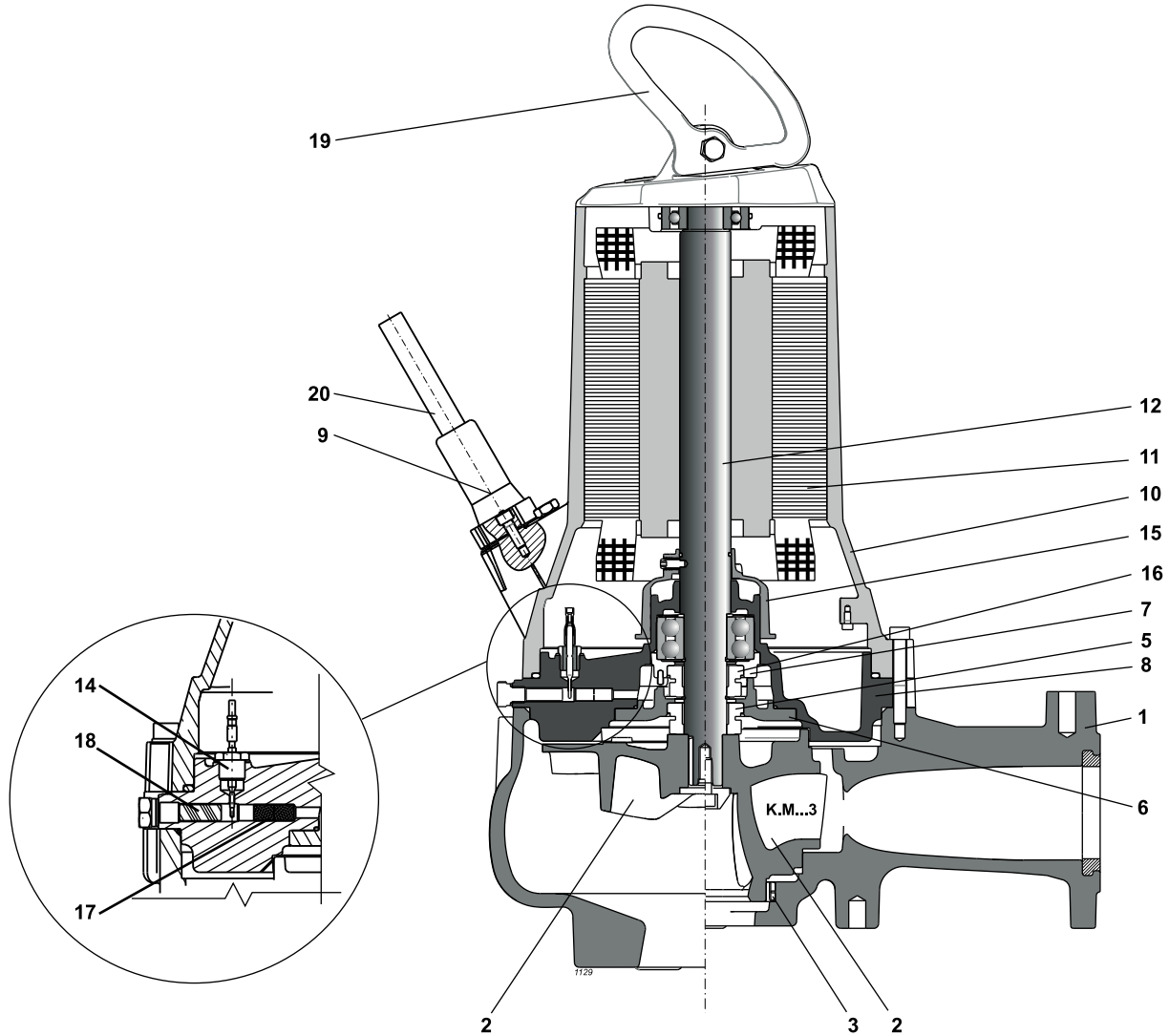

Pos.	Parts	Materials	Nomenclature	Matériaux	Nomenclatura	Materiale
1	Delivery body	Cast iron	Corps de refoulement	Fonte grise	Corpo mandata	Ghisa grigia
2	Impeller	Cast iron	Roue	Fonte grise	Girante	Ghisa grigia
3	Impeller wear ring	-	Bague d'usure	-	Anello sede girante	-
5	Mechanical seal on pump side	Silicon carbide/ceramic	Garniture mécanique côté pompe	carbure de silicium/ céramique	Tenuta meccanica lato pompa	Carburo di silicio/ ceramica
6	Flange for mechanical seal	Nodular cast iron	Bride porte garniture mécanique	Fonte sphéroïdale	Flangia porta tenuta meccanica	Ghisa sferoidale
7	Support bearing	Cast iron	Support de roulement	Fonte grise	Supporto cuscinetto	Ghisa grigia
8	Oil box	Cast iron	Chambre à huile	Fonte grise	Scatola olio	Ghisa grigia
9	Cable clamp	Stainless steel	Presse-étoupe	Acier inox	Pressacavo	Acciaio inox
10	Motor casing	Cast iron	Enveloppe du moteur	Fonte grise	Carcassa motore	Ghisa grigia
11	Stator	Electrical steel	Stator	Tôle magnétique	Statore	Lamierino magnetico
12	Complete shaft with rotor	Stainless steel/ Magnetic steel	Arbre avec rotor	Acier inox/Tôle magnétique	Albero completo di rotore	Acciaio inox/ Lamierino magnetico
14	Conductivity probe	-	Sondes de conductivité	-	Sonda di conduttività	-
15	Oil centrifuge	Technopolymer	Centrifugeur huile	Polymère technique	Centrifugatore olio	Tecnopolimero
16	Mechanical seal on motor side	Ceramic/graphite	Garniture mécanique côté moteur	Céramique/graphite	Tenuta meccanica lato motore	Ceramica/grafite
17	Flame arrester	-	Arrête-Flamme	-	Arrestatore di fiamma	-
18	Diaphragm	Steel/Rubber	Membrane	Acier/Caoutchouc	Membrana	Acciaio/Gomma
19	Handle	Stainless steel	Poignée	Acier inox	Maniglia	Acciaio inox
20	Round power cable	-	Câble rond d'alimentation	-	Cavo tondo di alimentazione	-

Screws and nuts in stainless steel.
Available version with AISI 316 stainless steel impeller.

Vis et écrous en acier inox
Disponible version Avec roue en acier inox AISI 316.

Viti e dadi in acciaio inox
Disponible versione con girante in acciaio inox AISI 316.

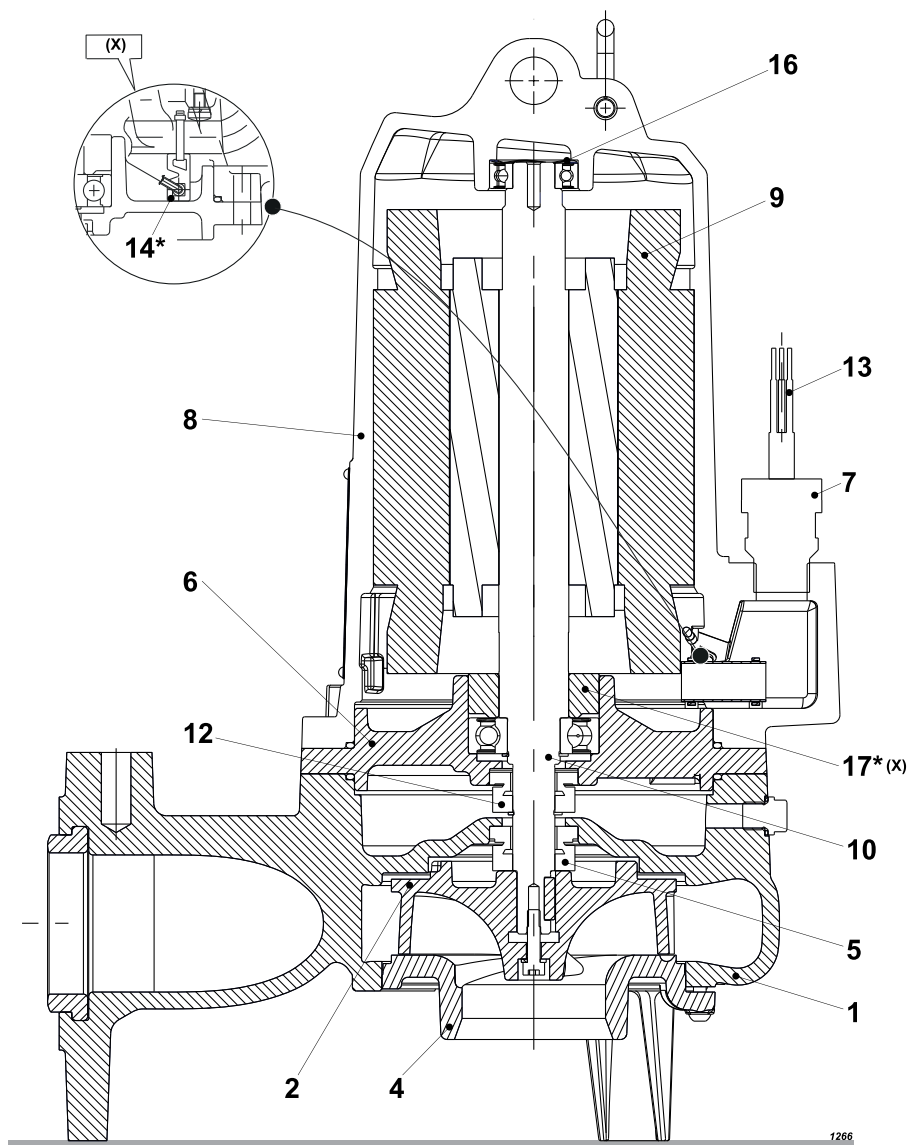

Pos.	Parts	Materials	Nomenclature	Matériaux	Nomenclatura	Materiale
1	Delivery body	Cast iron	Corps de refoulement	Fonte grise	Corpo mandata	Ghisa grigia
2	Impeller	Cast iron	Roue	Fonte grise	Girante	Ghisa grigia
4	Suction support	Nodular cast iron	Palier aspiration	Fonte sphéroïdale	Supporto aspirazione	Ghisa sferoidale
5	Mechanical seal on pump side	silicon carbide/ceramic	Garniture mécanique côté pompe	carbure de silicium/ céramique	Tenuta meccanica lato pompa	Carburo di silicio/ ceramica
6	Support bearing	Nodular cast iron	Support de roulement	Fonte sphéroïdale	Supporto cuscinetto	Ghisa sferoidale
7	Cable clamp	Brass	Presse-étoupe	Laiton	Pressacavo	Ottone
8	Motor casing	Cast iron	Enveloppe du moteur	Fonte grise	Carcassa motore	Ghisa grigia
9	Stator	Electrical steel	Stator	Tôle magnétique	Statore	Lamierino magnetico
10	Complete shaft with rotor	Stainless steel/ Magnetic steel	Arbre avec rotor	Acier inox/Tôle magnétique	Albero completo di rotore	Acciaio inox/ Lamierino magnetico
12	Mechanical seal on motor side	Ceramic/graphite	Garniture mécanique côté moteur	Céramique/graphite	Tenuta meccanica lato motore	Ceramica/grafite
13	Round power cable	-	Câble rond d'alimentation	-	Cavo tondo di alimentazione	-
14	Conductivity probe	-	Sondes de conductivité	-	Sonda di conduttività	-
16	Elastic ring	Stainless steel	Circlip	Acier inox	Anello elastico	Acciaio inox
17	Spacer sleeve	-	Entretoise	-	Distanziale	-
18	Handle (upon request)	Stainless steel	Poignée (sur demande)	Acier inox	Maniglia (su richiesta)	Acciaio inox

* For explosion-proof versions (X);
On demand for (N) versions.
(Conductivity probe in the motor casing)
Screws and nuts in stainless steel.
Available version with AISI 316 stainless steel impeller.

* Pour version antidéflagrantes (X);
Sur demande pour les versions (N).
(Sonde de conductivité dans l'enveloppe du moteur)
Vis et écrous en acier inox
Disponible version Avec roue en acier inox AISI 316.

* Per versioni antideflagranti (X);
su richiesta per versioni (N).
(Sonda di conduttività nella carcassa motore)
Viti e dadi in acciaio inox
Disponibile versione con girante in acciaio inox AISI 316.

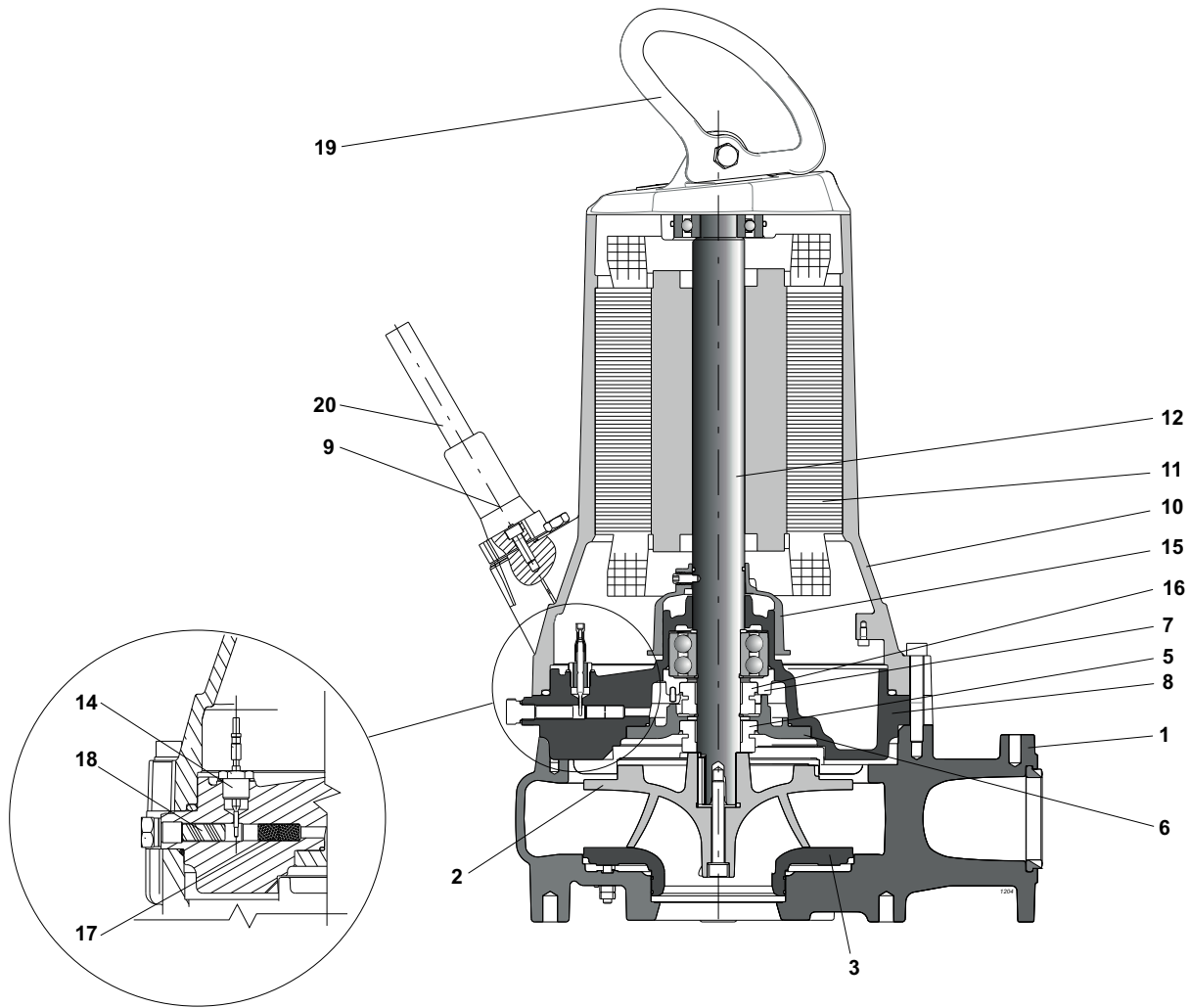

Pos.	Parts	Materials	Nomenclature	Matériaux	Nomenclatura	Materiale
1	Delivery body	Cast iron	Corps de refoulement	Fonte grise	Corpo mandata	Ghisa grigia
2	Impeller	Cast iron	Roue	Fonte grise	Girante	Ghisa grigia
3	Suction support	Nodular cast iron	Palier aspiration	Fonte sphéroïdale	Supporto aspirazione	Ghisa sferoidale
5	Mechanical seal on pump side	silicon carbide/ceramic	Garniture mécanique côté pompe	carbure de silicium/ céramique	Tenuta meccanica lato pompa	Carburo di silicio/ ceramica
6	Flange for mechanical seal	Nodular cast iron	Bride porte garniture mécanique	Fonte sphéroïdale	Flangia porta tenuta meccanica	Ghisa sferoidale
7	Support bearing	Cast iron	Support de roulement	Fonte grise	Supporto cuscinetto	Ghisa grigia
8	Oil box	Cast iron	Chambre à huile	Fonte grise	Scatola olio	Ghisa grigia
9	Cable clamp	Stainless steel	Presse-étoupe	Acier inox	Pressacavo	Acciaio inox
10	Motor casing	Cast iron	Enveloppe du moteur	Fonte grise	Carcassa motore	Ghisa grigia
11	Stator	Electrical steel	Stator	Tôle magnétique	Statore	Lamierino magnetico
12	Complete shaft with rotor	Stainless steel/ Magnetic steel	Arbre avec rotor	Acier inox/Tôle magnétique	Albero completo di rotore	Acciaio inox/ Lamierino magnetico
14	Conductivity probe	-	Sondes de conductivité	-	Sonda di conduttività	-
15	Oil centrifuge	Technopolymer	Centrifugeur huile	Polymère technique	Centrifugatore olio	Tecnopolimero
16	Mechanical seal on motor side	Ceramic/graphite	Garniture mécanique côté moteur	Céramique/graphite	Tenuta meccanica lato motore	Ceramica/grafite
17	Flame arrester	-	Arrête-Flamme	-	Arrestatore di fiamma	-
18	Diaphragm	Steel/Rubber	Membrane	Acier/Caoutchouc	Membrana	Acciaio/Gomma
19	Handle	Stainless steel	Poignée	Acier inox	Maniglia	Acciaio inox
20	Round power cable	-	Câble rond d'alimentation	-	Cavo tondo di alimentazione	-

* For explosion-proof versions (X);
On demand for (N) versions.
(Conductivity probe in the motor casing)
Screws and nuts in stainless steel.
Available version with AISI 316 stainless steel impeller.

* Pour version antidéflagrantes (X);
Sur demande pour les versions (N).
(Sonde de conductivité dans l'enveloppe du moteur)
Vis et écrous en acier inox
Disponible version Avec roue en acier inox AISI 316.

* Per versioni antideflagranti (X);
su richiesta per versioni (N).
(Sonda di conduttività nella carcassa motore)
Viti e dadi in acciaio inox
Disponibile versione con girante in acciaio inox AISI 316.

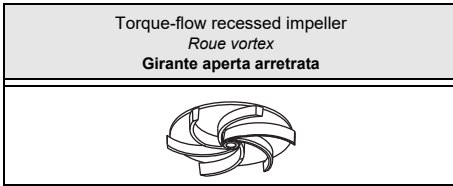

Type Type Tipo	KCW065F...41N3	KCW065F...41X3
Thermal probes <i>Sondes thermiques</i> Sonda termiche	On request <i>Sur demande</i> Su richiesta	Yes <i>Oui</i> Sì
Conductivity probe <i>Sonde de conductivité</i> Sonda di conduttività	On request <i>Sur demande</i> Su richiesta	Yes <i>Oui</i> Sì

Version cable (1) <i>Version câble (1)</i> Cavo Versione (1)		
Electric pump type <i>Electropompe type</i> Elettropompa tipo	Power supply <i>Alimentation</i> Alimentazione	Auxiliary <i>Auxiliaire</i> Ausiliario
KCW065FG+001641N3	1x(4x1,5)x10	
KCW065FD+002141N3	1x(4x1,5)x10	
KCW065FA+002641N3	1x(4x1,5)x10	

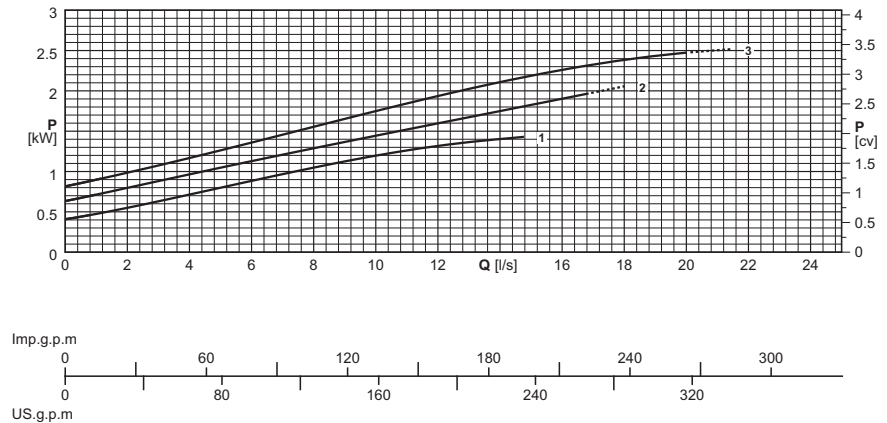
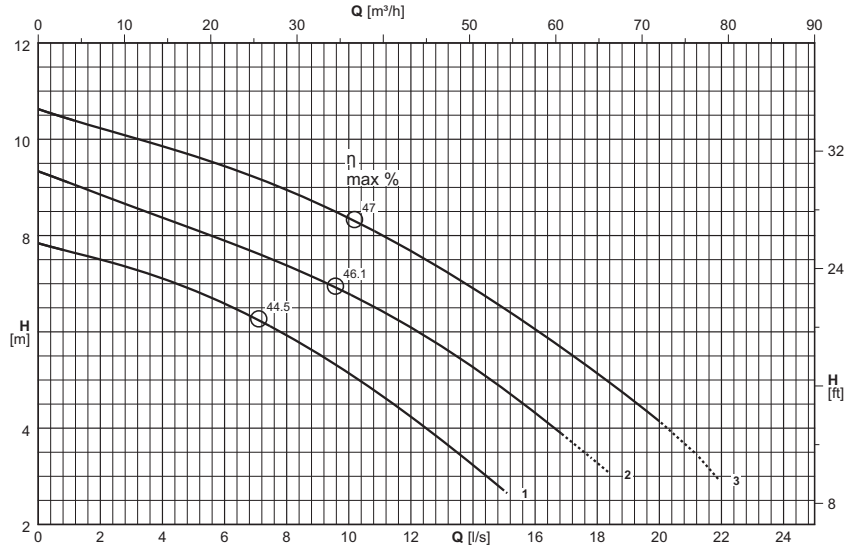

(1) = n°. of cables x (n°. of wires each cable x size [mm²]) x cable length [m] - Cable sheath in rubber H07RN8-F (Version+...41X3: Cable NSSHÖU-J)
Version+...41X3 Power supply:1x(7x1,5)x10
Cable length exceeding 10 m on request

(1) = n°. câbles x (n°. conducteurs câble x section [mm²]) x longueur câble [m] - Câble avec gaine en caoutchouc H07RN8-F (Version+...41X3: Câble NSSHÖU-J)
Version+...41X3 Alimentation:1x(7x1,5)x10
Sur demande longueur de câble supérieure à 10 m

(1) = n°. cavi x (n°. conduttori per cavo x sezione [mm²]) x lunghezza cavo [m] - Guaina cavo in gomma H07RN8-F (Versione+...41X3: Cavo NSSHÖU-J)
Versione+...41X3 Alimentazione:1x(7x1,5)x10
Lunghezza cavo superiore a 10 m - su richiesta

Electric pump type <i>Electropompe type</i> Elettropompa tipo	Curve <i>Courbe</i> Curva	Motor power <i>Puiss. moteur</i> Potenza motore	Capacity <i>Debit</i> Portata																	
			[l/s]	0	0,8	1	2	3	4	5	6	7	8	9	10	15	20	21		
			P ₂	[m³/h]	0	2,9	3,6	7,2	10,8	14,4	18	21,6	25,2	28,8	32,4	36	54	72	75,6	
			(N°)	[kW]	Head <i>Hauteur</i> Prevalenza															
KCW065FG+001641N3	1	1,6	[m]	7,8	7,7	7,7	7,5	7,3	7,1	6,9	6,6	6,3	5,9	5,5	5,1	2,7				
KCW065FD+002141N3	2	2,1	[m]	9,3	9,1	9,1	8,9	8,6	8,4	8,1	7,9	7,6	7,4	7,1	6,8	4,8				
KCW065FA+002641N3	3	2,6	[m]	10,6	10,5	10,4	10,2	10	9,9	9,7	9,4	9,2	8,9	8,7	8,4	6,5	4,1	3,6		

P₂ = Power rated by the motor
Performance tolerance as per:
UNI/ISO 9906 Grade 3B

For motor performances specification see page "motor features"

For the accessories specification see page "Accessories"

The impellers will be trimmed to meet the duty point

P₂ = Puissance restituée par le moteur
Tolérances sur les performances selon normes:
UNI/ISO 9906 Niveau 3B

Pour caractéristiques techniques moteurs voir page "Caractéristiques des moteurs"

Pour les accessoires voir page "Accessories"

Le point de fonctionnement désiré peut être obtenu par rognage de roue

P₂ = Potenza resa dal motore

Tolleranze sulle prestazioni secondo norme:
UNI/ISO 9906 Grado 3B

Per caratteristiche motori vedere pagina "caratteristiche motori"

Per accessori vedere pagina accessori

Le giranti vengono tornite in modo da ottenere il punto di lavoro richiesto

Permanent submersible version
Version fixe immergée
Esecuzione immersa fissa

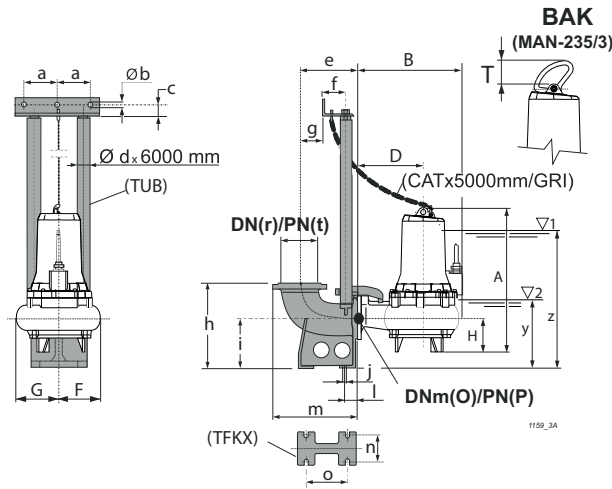

Type Type Tipo	Free passage Passage libre Passaggio Libero			Weight Poids Peso	A	B	D	F	G	H	O	P	T	Accessories Accessoires Accessori				
	[mm]	[mm]	[kg]															
KCW065FG+001641N3	Ø 55		63		565,6	373	225	148	148	140	65	16	65,3	F/E 2", F/E-A 2", E 2"				
KCW065FD+002141N3	Ø 55		68		565,6	373	225	148	148	140	65	16	65,3	F/E 2", F/E-A 2", E 2"				
KCW065FA+002641N3	Ø 55		66		565,6	373	225	148	148	140	65	16	65,3	F/E 2", F/E-A 2", E 2"				
BAK.	a	b	c	d	e	f	g	h	i	j	l	m	n	o	r	t	y	z
BAKF/E 2"	130	12,5	35	2"	220	102	40	280	160	18	47	320	110	156	80	ex PN10	250	415
BAKF/E-A 2"	130	12,5	35	2"	220	102	40	280	160	18	47	320	110	156	80	16	250	415
BAKE 2"	130	12,5	35	2"	220	102	40	280	160	18	47	312,5	110	156	65	16	250	415

(3) z = Minimum submergence depth for motor without casing with continuous duty S1 (NPSHR permitting)

(3) z = Immersion minimum pour moteur sans chemise en service continu S1 (compatible avec le NPSHR)

(3) z = Immersion minima per motore senza mantello in funzione continuo S1 compatibile con l'NPSHR

y = Minimum submergence depth for motor without casing with intermittent duty S3 (NPSHR permitting)

y = Immersion minimum pour moteur sans chemise en service intermittent S3 (compatible avec le NPSHR)

y = Immersion minima con motore senza mantello in funzione intermittente S3 compatibilmente con l'NPSHR

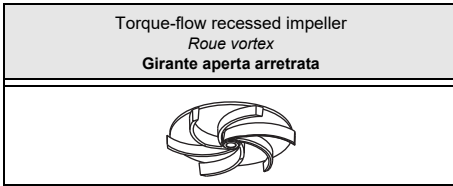

Type Type Tipo	KCW065F...21N3	KCW065F...21X3
Thermal probes Sondes termiques Sonda termiche	On request Sur demande Su richiesta	Yes Oui Sì
Conductivity probe Sonde de conductivité Sonda di conduttività	On request Sur demande Su richiesta	Yes Oui Sì

Version cable (1) <i>Version câble (1)</i> Cavo Versione (1)		
Electric pump type <i>Electropompe type</i> Elettropompa tipo	Power supply <i>Alimentation</i> Alimentazione	Auxiliary <i>Auxiliaire</i> Ausiliario
KCW065FL+002021N3	1x(4x1,5)x10	
KCW065FG+002521N3	1x(4x1,5)x10	
KCW065FD+003121N3	1x(4x1,5)x10	
KCW065FA+003121N3	1x(4x1,5)x10	

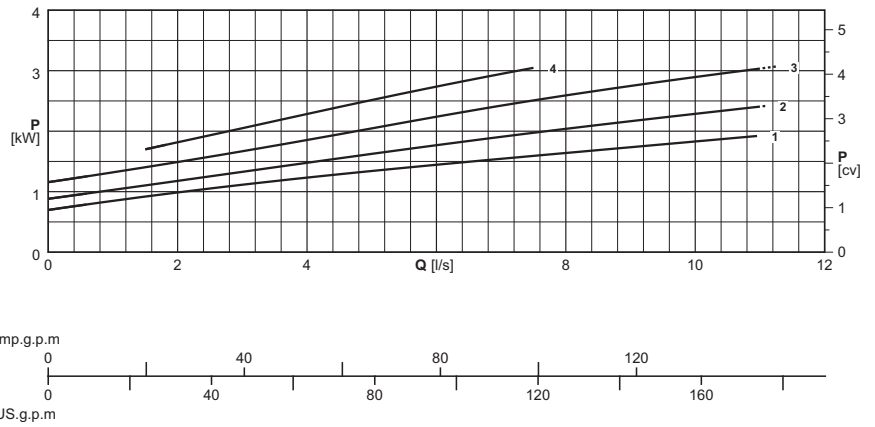
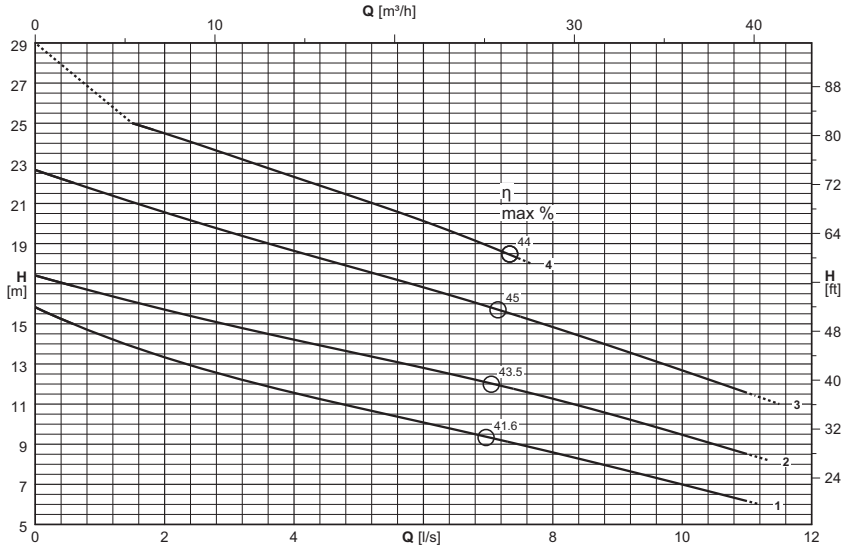

(1) = n°. of cables x (n°. of wires each cable x size [mm²]) x cable length [m] - Cable sheath in rubber H07RN8-F (Version+...21X3: Cable NSSHÖU-J)

Version+...21X3 Power supply:1x(7x1,5)x10
Cable length exceeding 10 m on request

(1) = n°. câbles x (n°. conducteurs câble x section [mm²]) x longueur câble [m] - Câble avec gaine en caoutchouc H07RN8-F (Version+...21X3: Câble NSSHÖU-J)

Version+...21X3 Alimentation:1x(7x1,5)x10
Sur demande longueur de câble supérieure à 10 m

(1) = n°. cavi x (n°. conduttori per cavo x sezione [mm²]) x lunghezza cavo [m] - Guaina cavo in gomma H07RN8-F (Versione+...21X3: Cavo NSSHÖU-J)

Versione+...21X3 Alimentazione:1x(7x1,5)x10
Lunghezza cavo superiore a 10 m - su richiesta

Electric pump type <i>Electropompe type</i> Elettropompa tipo	Curve <i>Courbe</i> Curva	Motor power <i>Puiss. moteur</i> Potenza motore	Capacity <i>Debit</i> Portata																		
			[l/s]	0	0,6	0,7	0,8	0,9	1	2	3	4	5	6	7	8	9	10	11		
			P ₂	[m³/h]	0	2,2	2,5	2,9	3,2	3,6	7,2	10,8	14,4	18	21,6	25,2	28,8	32,4	36	39,6	
			(N°)	[kW]	Head <i>Hauteur</i> Prevalenza																
			[m]	[m]	15,8	15	14,9	14,7	14,6	14,5	13,3	12,4	11,6	10,8	10,1	9,3	8,6	7,8	7	6,2	
KCW065FL+002021N3	1	2	[m]	[m]	17,6	16,9	16,8	16,7	16,6	16,5	15,7	14,9	14,2	13,5	12,8	12,1	11,3	10,4	9,5	8,5	
KCW065FG+002521N3	2	2,5	[m]	[m]	22,7	22	21,9	21,8	21,7	21,6	20,6	19,6	18,6	17,7	16,8	15,9	14,8	13,8	12,7	11,6	
KCW065FD+003121N3	3	3,1	[m]	[m]	26,8						24,5	23,4	22,3	21,2	20,1	18,9					
KCW065FA+003121N3	4	3,1	[m]	[m]																	

P₂ = Power rated by the motor

Performance tolerance as per:
UNI/ISO 9906 Grade 3B

For motor performances specification see page "motor features"

For the accessories specification see page "Accessories"

The impellers will be trimmed to meet the duty point

P₂ = Puissance restituée par le moteur

Tolérances sur les performances selon normes:
UNI/ISO 9906 Niveau 3B

Pour caractéristiques techniques moteurs voir page "Caractéristiques des moteurs"

Pour les accessoires voir page "Accessories"

Le point de fonctionnement désiré peut être obtenu par rognage de roue

P₂ = Potenza resa dal motore

Tolleranze sulle prestazioni secondo norme:
UNI/ISO 9906 Grado 3B

Per caratteristiche motori vedere pagina "caratteristiche motori"

Per accessori vedere pagina accessori

Le giranti vengono tornite in modo da ottenere il punto di lavoro richiesto

Permanent submersible version
Version fixe immergée
Esecuzione immersa fissa

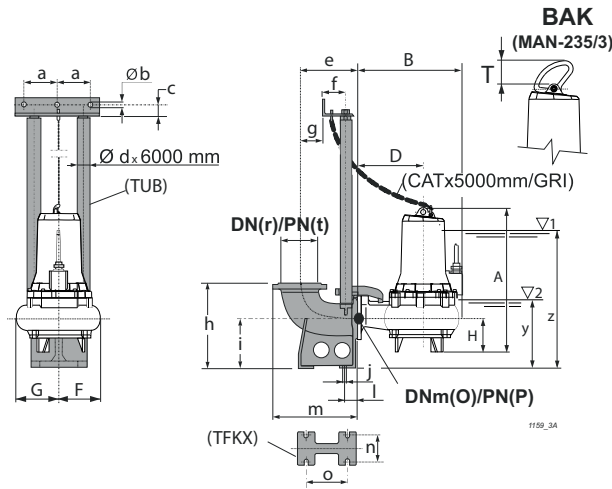

Type Type Tipo	Free passage Passage libre Passaggio Libero			Weight Poids Peso	A	B	D	F	G	H	O	P	T	Accessories Accessoires Accessori				
	[mm]	[mm]	[kg]															
KCW065FL+002021N3	Ø 40		54	529,6	363	225	113	113	107,5	65	16	65,3	F/E 2", F/E-A 2", E 2"					
KCW065FG+002521N3	Ø 40		56	529,6	370	225	113	113	107,5	65	16	65,3	F/E 2", F/E-A 2", E 2"					
KCW065FD+003121N3	Ø 40		62	533,6	370	225	113	113	107,5	65	16	65,3	F/E 2", F/E-A 2", E 2"					
KCW065FA+003121N3	Ø 40		61	533,6	370	225	113	113	107,5	65	16	65,3	F/E 2", F/E-A 2", E 2"					
BAK.	a	b	c	d	e	f	g	h	i	j	l	m	n	o	r	t	y	z
BAKF/E 2"	130	12,5	35	2"	220	102	40	280	160	18	47	320	110	156	80	ex PN10	252,5	442,5
BAKF/E-A 2"	130	12,5	35	2"	220	102	40	280	160	18	47	320	110	156	80	16	252,5	442,5
BAKE 2"	130	12,5	35	2"	220	102	40	280	160	18	47	312,5	110	156	65	16	252,5	442,5

(3) z = Minimum submergence depth for motor without casing with continuous duty S1 (NPSHR permitting)

y = Minimum submergence depth for motor without casing with intermittent duty S3 (NPSHR permitting)

(3) z = Immersion minimum pour moteur sans chemise en service continu S1 (compatible avec le NPSHR)

y = Immersion minimum pour moteur sans chemise en service intermittent S3 (compatible avec le NPSHR)

(3) z = Immersion minima per motore senza mantello in funzione continuo S1 compatibilmente con l'NPSHR

y = Immersione minima con motore senza mantello in funzione intermittente S3 compatibilmente con l'NPSHR

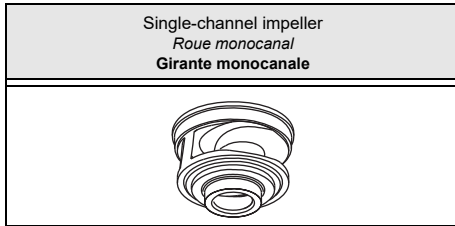

Type Type Tipo	KCM065F...+...21N3	KCM065F...+...21X3
Thermal probes Sondes thermiques Sonda termiche	On request Sur demande Su richiesta	Yes Oui Si
Conductivity probe Sonde de conductivité Sonda di conduttività	On request Sur demande Su richiesta	Yes Oui Si

Version cable (1)
Version câble (1)
Cavo Versione (1)

Electric pump type Electropompe type Elettropompa tipo	Power supply Alimentation Alimentazione	Auxiliary Auxiliaire Ausiliario
KCM065FG+002021N3	1x(4x1,5)x10	
KCM065FD+002021N3	1x(4x1,5)x10	
KCM065FA+002521N3	1x(4x1,5)x10	
KCM065FK+003121N3	1x(4x1,5)x10	

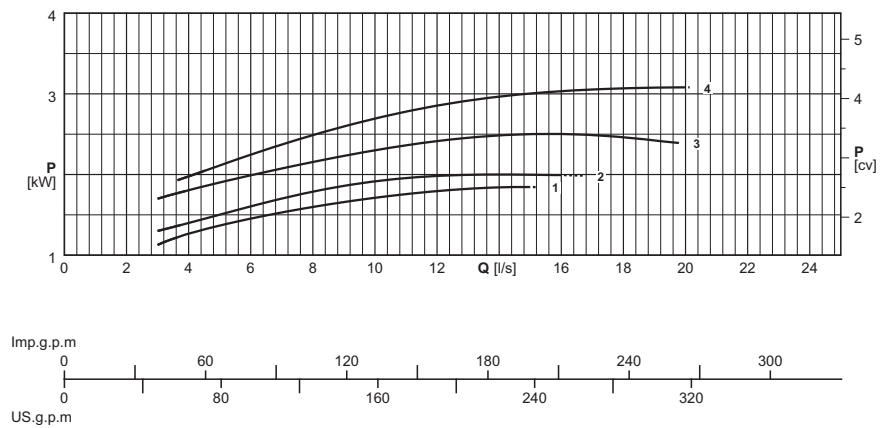
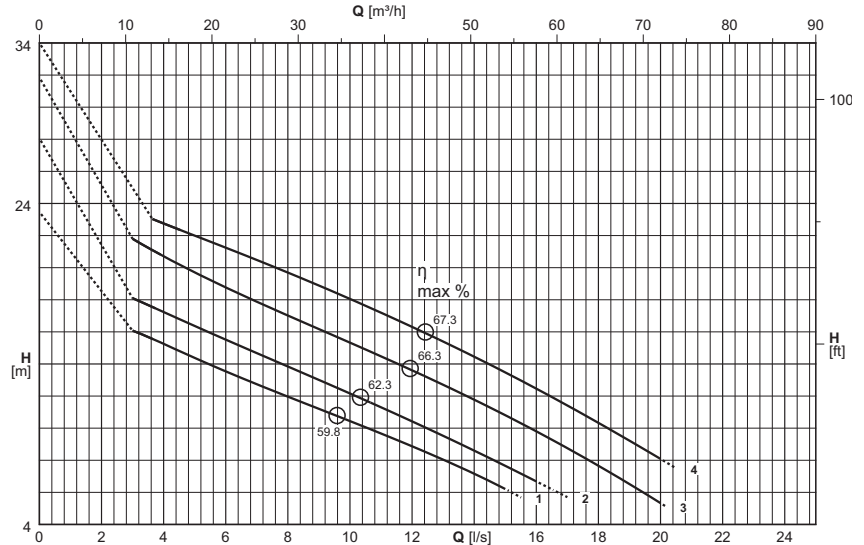

(1) = n°. of cables x (n°. of wires each cable x size [mm²]) x cable length [m] - Cable sheath in rubber H07RN8-F (Versione+...21X3: Cable NSSHÖU-J)
Version+...21X3 Power supply:1x(7x1,5)x10
Cable length exceeding 10 m on request

(1) = n°. câbles x (n°. conducteurs câble x section [mm²]) x longueur câble [m] - Câble avec gaine en caoutchouc H07RN8-F (Versione+...21X3: Câble NSSHÖU-J)
Version+...21X3 Alimentation:1x(7x1,5)x10
Sur demande longueur de câble supérieure à 10 m

(1) = n°. cavi x (n°. conduttori per cavo x sezione [mm²]) x lunghezza cavo [m] - Guaina cavo in gomma H07RN8-F (Versione+...21X3: Cavo NSSHÖU-J)
Versione+...21X3 Alimentazione:1x(7x1,5)x10
Lunghezza cavo superiore a 10 m - su richiesta

Electric pump type Electropompe type Elettropompa tipo	Curve Courbe Curva	Motor power Puiss. moteur Potenza motore	Capacity Débit Portata															
			[l/s]	0	3	4	5	6	7	8	9	10	12	14	16	18	20	
		P ₂	[m³/h]	0	10,8	14,4	18	21,6	25,2	28,8	32,4	36	43,2	50,4	57,6	64,8	72	
	(N°)	[kW]	Head Hauteur Prevalenza															
			[m]	19,5	16,1	15,2	14,4	13,5	12,7	12	11,2	10,4	8,9	7,2				
KCM065FG+002021N3	1	2	[m]	19,5	16,1	15,2	14,4	13,5	12,7	12	11,2	10,4	8,9	7,2				
KCM065FD+002021N3	2	2	[m]	24,1	18,1	17,2	16,4	15,5	14,7	13,8	13	12,2	10,4	8,6	6,7			
KCM065FA+002521N3	3	2,5	[m]	27,9	21,8	20,7	19,7	18,8	17,9	17	16,2	15,3	13,6	11,8	9,8	7,7	5,3	
KCM065FK+003121N3	4	3,1	[m]	30,4			22,8	22	21,2	20,5	19,7	18,9	18,1	16,3	14,4	12,5	10,3	8,1

P₂ = Power rated by the motor
Performance tolerance as per:
UNI/ISO 9906 Grade 3B
For motor performances specification see page "motor features"
For the accessories specification see page "Accessories"

P₂ = Puissance restituée par le moteur
Tolérances sur les performances selon normes:
UNI/ISO 9906 Niveau 3B
Pour caractéristiques techniques moteurs voir page "Caractéristiques des moteurs"
Pour les accessoires voir page "Accessories"

P₂ = Potenza resa dal motore
Tolleranze sulle prestazioni secondo norme:
UNI/ISO 9906 Grado 3B
Per caratteristiche motori vedere pagina "caratteristiche motori"
Per accessori vedere pagina accessori

Permanent submersible version
Version fixe immergée
Esecuzione immersa fissa

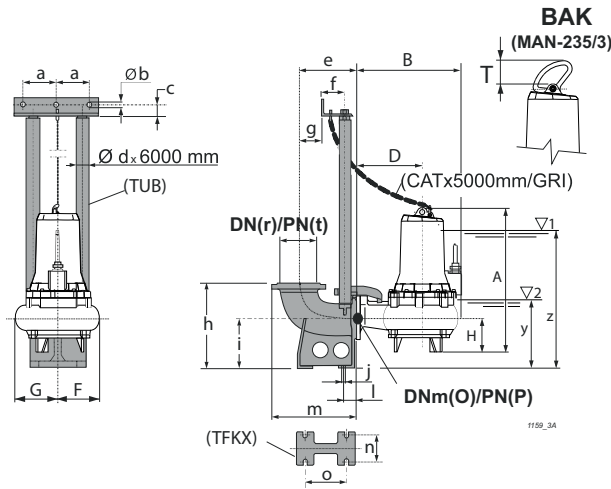

Type Type Tipo	Free passage Passage libre Passaggio Libero	Weight Poids Peso	A	B	D	F	G	H	O	P	T	Accessories Accessoires Accessori								
	[mm]	[kg]	[mm]									BAK.								
KCM065FG+002021N3	Ø 40	61	561,6	373	225	148	148	140	65	16	65,3	F/E 2", F/E-A 2", E 2"								
KCM065FD+002021N3	Ø 40	60	561,6	373	225	148	148	140	65	16	65,3	F/E 2", F/E-A 2", E 2"								
KCM065FA+002521N3	Ø 40	62	561,6	373	225	148	148	140	65	16	65,3	F/E 2", F/E-A 2", E 2"								
KCM065FK+003121N3	Ø 40	62	565,6	373	225	148	148	140	65	16	65,3	F/E 2", F/E-A 2", E 2"								
BAK.			a	b	c	d	e	f	g	h	i	j	l	m	n	o	r	t	y	z
BAKF/E 2"			130	12,5	35	2"	220	102	40	280	160	18	47	320	110	156	80	ex PN10	253	443
BAKF/E-A 2"			130	12,5	35	2"	220	102	40	280	160	18	47	320	110	156	80	16	253	443
BAKE 2"			130	12,5	35	2"	220	102	40	280	160	18	47	312,5	110	156	65	16	253	443

(3) z = Minimum submergence depth for motor without casing with continuous duty S1 (NPSHR permitting)

y = Minimum submergence depth for motor without casing with intermittent duty S3 (NPSHR permitting)

(3) z = Immersion minimum pour moteur sans chemise en service continu S1 (compatible avec le NPSHR)

y = Immersion minimum pour moteur sans chemise en service intermittent S3 (compatible avec le NPSHR)

(3) z = Immersion minima per motore senza mantello in funzione continuo S1 compatibilmente con l'NPSHR

y = Immersion minima con motore senza mantello in funzione intermittente S3 compatibilmente con l'NPSHR

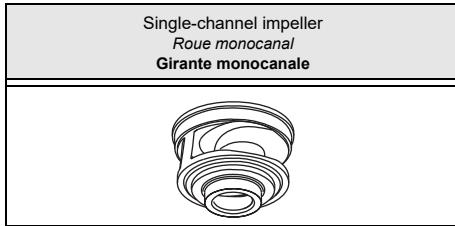

Type Type Tipo	KCM065H...+...21N3	KCM065H...+...21X3
Thermal probes <i>Sondes thermiques</i> Sonda termiche	Yes <i>Oui</i> Sì	Yes <i>Oui</i> Sì
Conductivity probe <i>Sonde de conductivité</i> Sonda di conduttività	Yes <i>Oui</i> Sì	Yes <i>Oui</i> Sì

Version cable (1)
Version câble (1)
Cavo Versione (1)

Electric pump type <i>Electropompe type</i> Elettropompa tipo	Power supply <i>Alimentation</i> Alimentazione	Auxiliary <i>Auxiliaire</i> Ausiliario
KCM065HL+003821N3	1x(7x1,5)x10	
KCM065HG+003821N3	1x(7x1,5)x10	
KCM065HD+004821N3	1x(7x1,5)x10	
KCM065HA+004821N3	1x(7x1,5)x10	

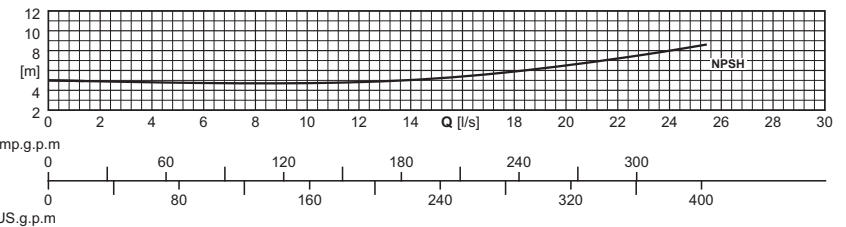
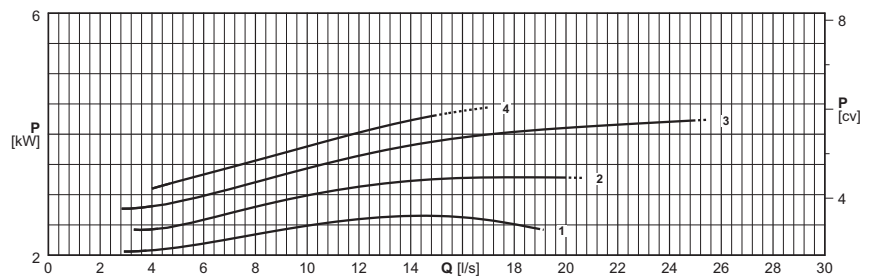
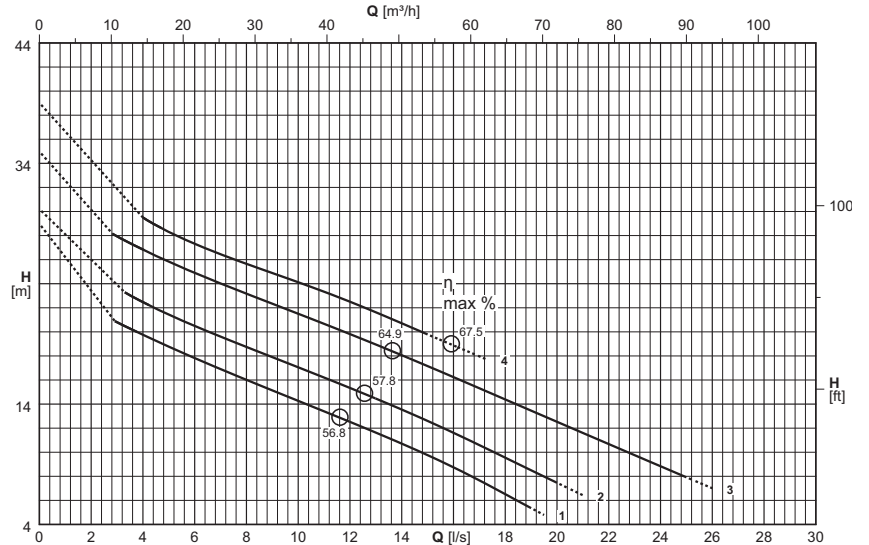

(1) = n°. of cables x (n°. of wires each cable x size [mm²]) x cable length [m] - Câble NSSHOU-J

Version+...21X3 Power supply:1x(7x1,5)x10

Cable length exceeding 10 m on request

(1) = n°. câbles x (n°. conducteurs câble x section [mm²]) x longueur câble [m] - Câble NSSHOU-J

Version+...21X3 Alimentation:1x(7x1,5)x10

Sur demande longueur de câble supérieure à 10 m

(1) = n°. cavi x (n°. conduttori per cavo x sezione [mm²]) x lunghezza cavo [m] - Cavo NSSHOU-J

Versione+...21X3 Alimentazione:1x(7x1,5)x10

Lunghezza cavo superiore a 10 m - su richiesta

Electric pump type <i>Electropompe type</i> Elettropompa tipo	Curve <i>Courbe</i> Curva	Motor power <i>Puiss. moteur</i> Potenza motore	Capacity <i>Debit</i> Portata																	
			[l/s]	0	3	4	5	6	7	8	9	10	12,5	15	17,5	20	22,5	25	26	
		P ₂	[m³/h]	0	10,8	14,4	18	21,6	25,2	28,8	32,4	36	45	54	63	72	81	90	93,6	
	(N°)	[kW] <th colspan="16">Head <i>Hauteur</i> Prevalenza</th>	Head <i>Hauteur</i> Prevalenza																	
KCM065HL+003821N3	1	3,8	[m]	25	20,8	19,8	18,8	17,8	16,9	16	15,1	14,3	12,1	9,8	7,1					
KCM065HG+003821N3	2	3,8	[m]	26,2		22,5	21,4	20,5	19,6	18,7	17,9	17,1	14,9	12,6	10,1	7,5				
KCM065HD+004821N3	3	4,8	[m]	31	28	26,8	25,8	24,9	24	23,2	22,3	21,5	19,4	17,2	14,9	12,5	10,2	7,9	7	
KCM065HA+004821N3	4	4,8	[m]	35		29,5	28,3	27,3	26,5	25,7	24,9	24,1	22,1	19,8						

P₂ = Power rated by the motor

Performance tolerance as per:
UNI/ISO 9906 Grade 3B

For motor performances specification see page "motor features"

For the accessories specification see page "Accessories"

P₂ = Puissance restituée par le moteur

Tolérances sur les performances selon normes:
UNI/ISO 9906 Niveau 3B

Pour caractéristiques techniques moteurs voir page "Caractéristiques techniques des moteurs"

Pour les accessoires voir page "Accessories"

P₂ = Potenza resa dal motore

Tolleranze sulle prestazioni secondo norme:
UNI/ISO 9906 Grado 3B

Per caratteristiche motori vedere pagina "caratteristiche motori"

Per accessori vedere pagina accessori

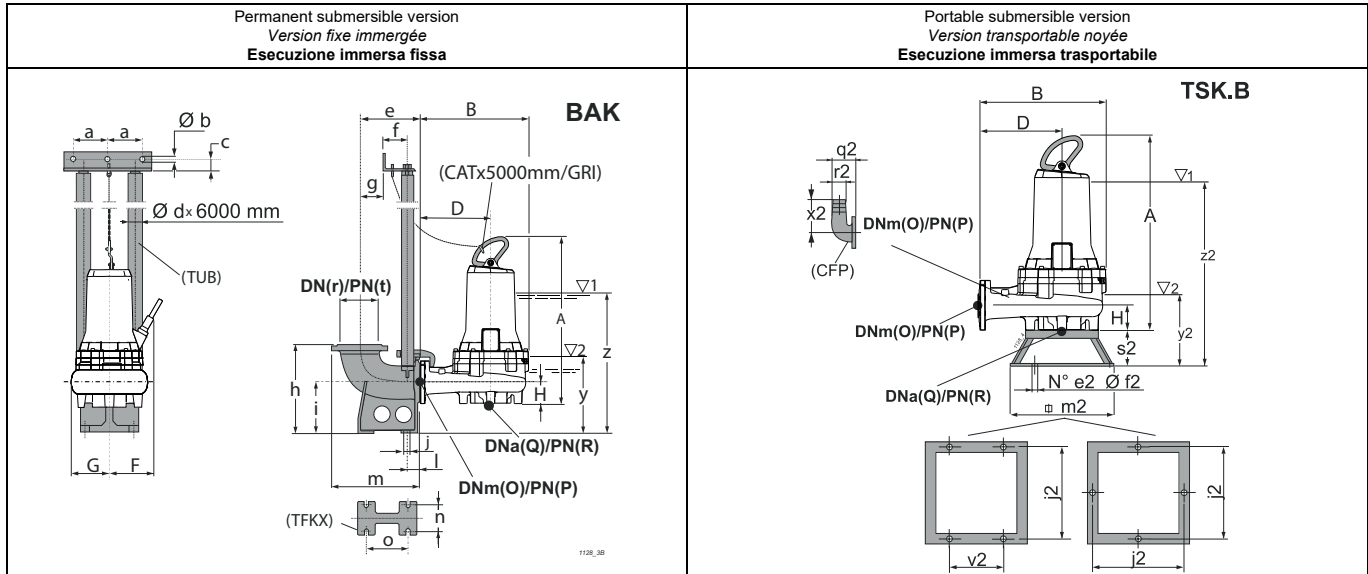

Permanent submersible version
Version fixe immergée
Esecuzione immersa fissa

Portable submersible version
Version transportable noyée
Esecuzione immersa trasportabile

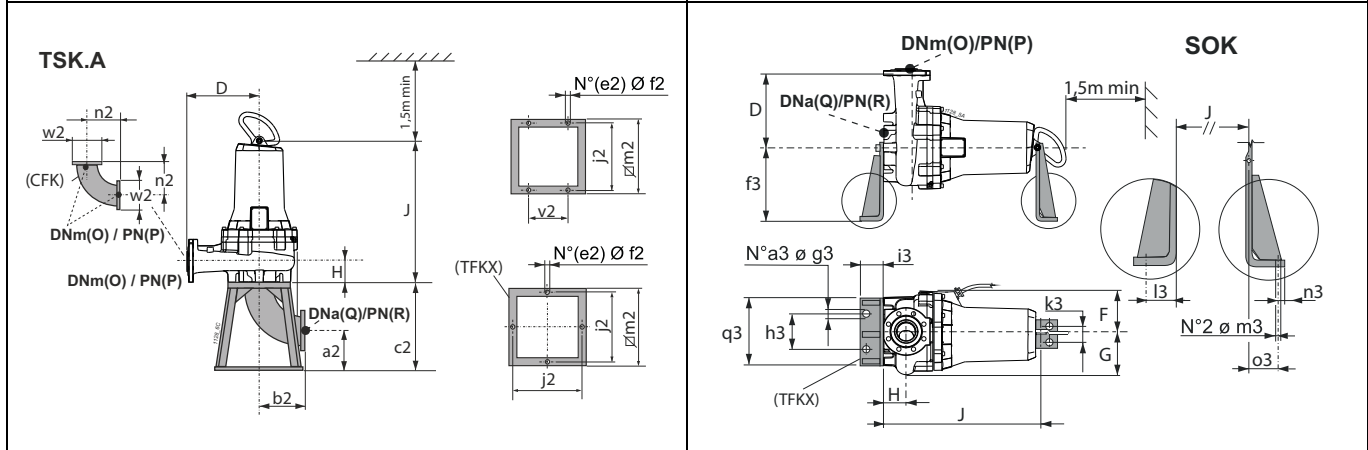

For fixed installation in a dry chamber - vertical (R)
Pour installation fixe en fosse sèche - verticale (R)
Esecuzione per camera asciutta - verticale (R)

For fixed installation in a dry chamber - horizontal (R)
Pour installation fixe en fosse sèche - horizontale (R)
Esecuzione per camera asciutta - orizzontale (R)

Type Type Tipo	Free passage Passage libre Passaggio Libero	Weight Poids Peso	A	B	D	F	G	H	J	O	P	Q	R	Accessories Accessoires Accessori			
			[mm]	[kg]	[mm]											BAK.	SOK.
KCM065HL+003821N3	Ø 40	88,7	601,7	390	245	204,5	145	80,5	516,4	65	16	65	16 (*)	F/E 2", F/E-A 2", E 2"	80/N3	K65	80
KCM065HG+003821N3	Ø 40	88,7	601,7	390	245	204,5	145	80,5	516,4	65	16	65	16 (*)	F/E 2", F/E-A 2", E 2"	80/N3	K65	80
KCM065HD+004821N3	Ø 40	93,3	601,7	390	245	204,5	145	80,5	516,4	65	16	65	16 (*)	F/E 2", F/E-A 2", E 2"	80/N3	K65	80
KCM065HA+004821N3	Ø 40	93,3	601,7	390	245	204,5	145	80,5	516,4	65	16	65	16 (*)	F/E 2", F/E-A 2", E 2"	80/N3	K65	80

BAK.	a	b	c	d	e	f	g	h	i	j	l	m	n	o	r	t	y	z
BAKF/E 2"	130	12,5	35	2"	220	102	40	280	160	18	47	320	110	156	80	ex PN10	231,9	483,9
BAKF/E-A 2"	130	12,5	35	2"	220	102	40	280	160	18	47	320	110	156	80	16	231,9	483,9
BAKE 2"	130	12,5	35	2"	220	102	40	280	160	18	47	312,5	110	156	65	16	231,9	483,9
SOK.	a3	f3	g3	h3	i3	k3	l3	m3	n3	o3	q3							
SOK80/N3	2	400	22	270	100	100	66	22	34	43	400							
TSK.A	a2	b2	c2	e2	f2	j2	m2	n2	v2	w2								
TSKK65A	150	140	290	4	12	390	440	140	230	185								
TSK.B	e2	f2	j2	m2	q2	r2	s2	v2	x2	y2	z2							
TSKB0B	4	12	400	440	135	75	166	230	200	318,4	570,4							

(3) z = Minimum submergence depth for motor without casing with continuous duty S1 (NPSHR permitting)
(3) z = Immersion minimum pour moteur sans chemise en service continu S1 (compatible avec le NPSHR)
(3) z = Immersion minima per motore senza mantello in funzione continuo S1 compatibilmente con l'NPSHR

y = Minimum submergence depth for motor without casing with intermittent duty S3 (NPSHR permitting)
y = Immersion minimum pour moteur sans chemise en service intermittent S3 (compatible avec le NPSHR)
y = Immersion minima con motore senza mantello in funzione intermittente S3 compatibilmente con l'NPSHR

(*) Consult the flanges page.
(*) Voir page brides.
(*) Vedere pagina flange.

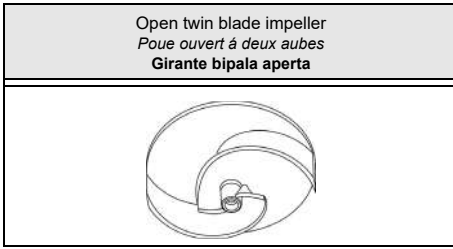

Type Type Tipo	KCA065F.+...21N3	KCA065F.+...21X3
Thermal probes Sondes thermiques Sonde termiche	On request Sur demande Su richiesta	Yes Oui Sì
Conductivity probe Sonde de conductivité Sonda di conduttività	On request Sur demande Su richiesta	Yes Oui Sì

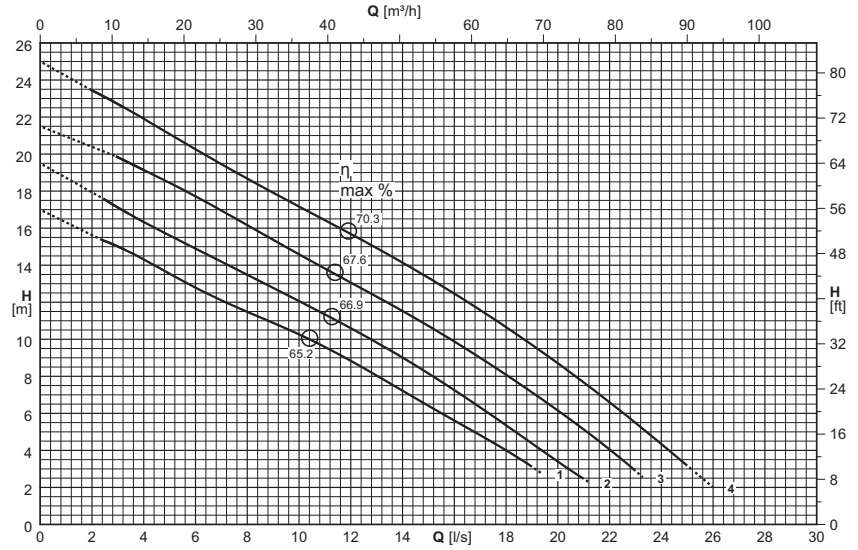

Version cable (1) Version câble (1) Cavo Versione (1)		
Electric pump type Electropompe type Elettropompa tipo	Power supply Alimentation Alimentazione	Auxiliary Auxiliaire Ausiliario
KCA065FL+002021N3	1x(4x1,5)x10	
KCA065FG+002021N3	1x(4x1,5)x10	
KCA065FD+002521N3	1x(4x1,5)x10	
KCA065FA+003121N3	1x(4x1,5)x10	

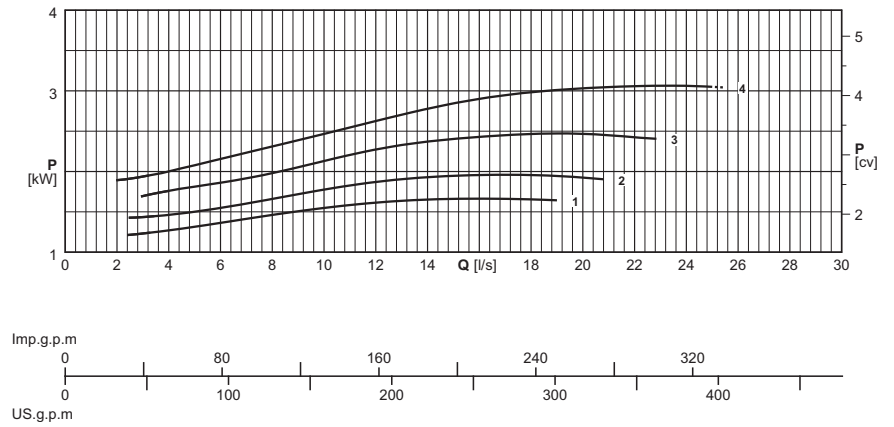

(1) = n°. of cables x (n°. of wires each cable x size [mm²]) x cable length [m] - Câble sheath in rubber H07RN8-F (Version+...21X3: Cable NSSHÔU-J)
Version+...21X3 Alimentation:1x(7x1,5)x10
Cable length exceeding 10 m on request

(1) = n°. câbles x (n°. conducteurs câble x section [mm²]) x longueur câble [m] - Câble avec gaine en caoutchouc H07RN8-F (Version+...21X3: Câble NSSHÔU-J)
Version+...21X3 Alimentation:1x(7x1,5)x10
Sur demande longueur de câble supérieure à 10 m

(1) = n°. cavi x (n°. conduttori per cavo x sezione [mm²]) x lunghezza cavo [m] - Guaina cavo in gomma H07RN8-F (Versione+...21X3: Cavo NSSHÔU-J)
Versione+...21X3 Alimentazione:1x(7x1,5)x10
Lunghezza cavo superiore a 10 m - su richiesta

Electric pump type Electropompe type Elettropompa tipo	Curve Courbe Curva	Motor power Puiss. moteur Potenza motore	Capacity Débit Portata																		
			[l/s]	0	2	3	4	5	6	7	8	9	10	12,5	15	17,5	20	22,5	25	26	
		P ₂	[m³/h]	0	7,2	10,8	14,4	18	21,6	25,2	28,8	32,4	36	45	54	63	72	81	90	93,6	
	(N°)	[kW]	Head Hauteur Prevalenza																		
			[m]	17		15	14,3	13,5	12,8	12,1	11,5	10,9	10,3	8,4	6,4	4,4					
KCA065FL+002021N3	1	2	[m]	17		15	14,3	13,5	12,8	12,1	11,5	10,9	10,3	8,4	6,4	4,4					
KCA065FG+002021N3	2	2	[m]	19,5		17,1	16,3	15,6	14,9	14,2	13,5	12,8	12,1	10,2	8,1	5,8	3,4				
KCA065FD+002521N3	3	2,5	[m]	21,5		19,8	19,1	18,4	17,7	16,9	16,2	15,4	14,6	12,7	10,7	8,5	6,2	3,5			
KCA065FA+003121N3	4	3,1	[m]	25	23,4	22,7	21,9	21,1	20,3	19,5	18,7	17,9	17,2	15,3	13,3	11,1	8,7	6	3,2	2	

P₂ = Power rated by the motor
Performance tolerance as per:
UNI/ISO 9906 Grade 3B
For motor performances specification see page "motor features"
For the accessories specification see page "Accessories"
The impellers will be trimmed to meet the duty point

P₂ = Puissance restituée par le moteur
Tolérances sur les performances selon normes:
UNI/ISO 9906 Niveau 3B
Pour caractéristiques techniques moteurs voir page "Caractéristiques des moteurs"
Pour les accessoires voir page "Accessories"
Le point de fonctionnement désiré peut être obtenu par rognage de roue

P₂ = Potenza resa dal motore
Tolleranze sulle prestazioni secondo norme:
UNI/ISO 9906 Grado 3B
Per caratteristiche motori vedere pagina "caratteristiche motori"
Per accessori vedere pagina accessori
Le giranti vengono tornite in modo da ottenere il punto di lavoro richiesto

Permanent submersible version
Version fixe immergée
Esecuzione immersa fissa

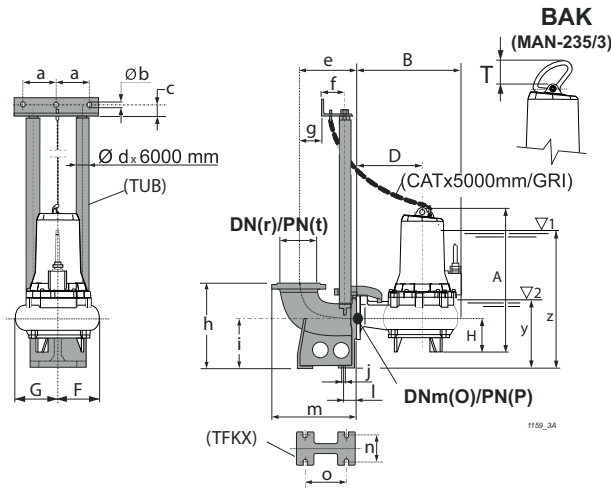

Type Type Tipo	Free passage Passage libre Passaggio Libero			Weight Poids Peso	A	B	D	F	G	H	O	P	T	Accessories Accessoires Accessori				
	[mm]	[mm]	[kg]															
KCA065FL+002021N3	---	---	54	518,6	370	225	113	131	103	65	16	65,3	F/E 2", F/E-A 2", E 2"					
KCA065FG+002021N3	---	---	54	518,6	370	225	113	131	103	65	16	65,3	F/E 2", F/E-A 2", E 2"					
KCA065FD+002521N3	---	---	56	518,6	370	225	113	131	103	65	16	65,3	F/E 2", F/E-A 2", E 2"					
KCA065FA+003121N3	---	---	56	522,6	370	225	113	131	103	65	16	65,3	F/E 2", F/E-A 2", E 2"					
BAK.																		
	a	b	c	d	e	f	g	h	i	j	l	m	n	o	r	t	y	z
BAKF/E 2"	130	12,5	35	2"	220	102	40	280	160	18	47	320	110	156	80	ex PN10	244	409
BAKF/E-A 2"	130	12,5	35	2"	220	102	40	280	160	18	47	320	110	156	80	16	244	409
BAKE 2"	130	12,5	35	2"	220	102	40	280	160	18	47	312,5	110	156	65	16	244	409

(3) z = Minimum submergence depth for motor without casing with continuous duty S1 (NPSHR permitting)
y = Minimum submergence depth for motor without casing with intermittent duty S3 (NPSHR permitting)

(3) z = Immersion minimum pour moteur sans chemise en service continu S1 (compatible avec le NPSHR)
y = Immersion minimum pour moteur sans chemise en service intermittent S3 (compatible avec le NPSHR)

(3) z = Immersion minima per motore senza mantello in funzione continuo S1 compatibilmente con l'NPSHR
y = Immersione minima con motore senza mantello in funzione intermittente S3 compatibilmente con l'NPSHR

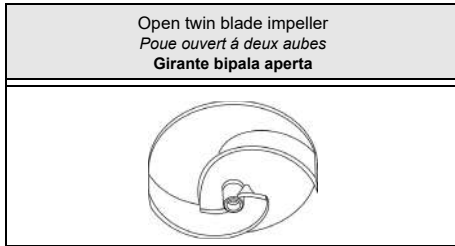

Type Type Tipo	KCA065H...21N3	KCA065H...21X3
Thermal probes Sondes thermiques Sonde termiche	Yes Oui Sì	Yes Oui Sì
Conductivity probe Sonde de conductivité Sonda di conduttività	Yes Oui Sì	Yes Oui Sì

Version cable (1)
Version câble (1)
Cavo Versione (1)

Electric pump type Electropompe type Elettropompa tipo	Power supply Alimentation Alimentazione	Auxiliary Auxiliaire Ausiliario
KCA065HL+003821N3	1x(7x1,5)x10	
KCA065HG+003821N3	1x(7x1,5)x10	
KCA065HD+004821N3	1x(7x1,5)x10	
KCA065HA+006522N3	1x(10x2,5)x10	

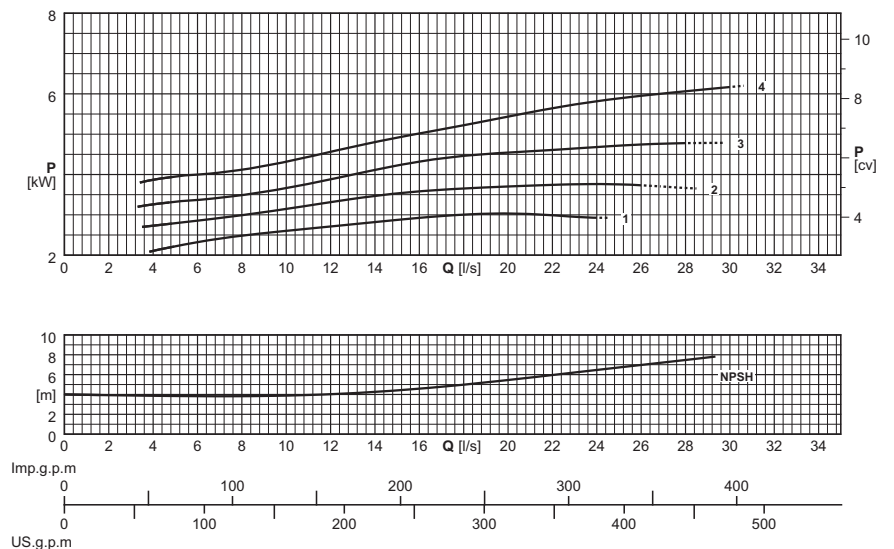
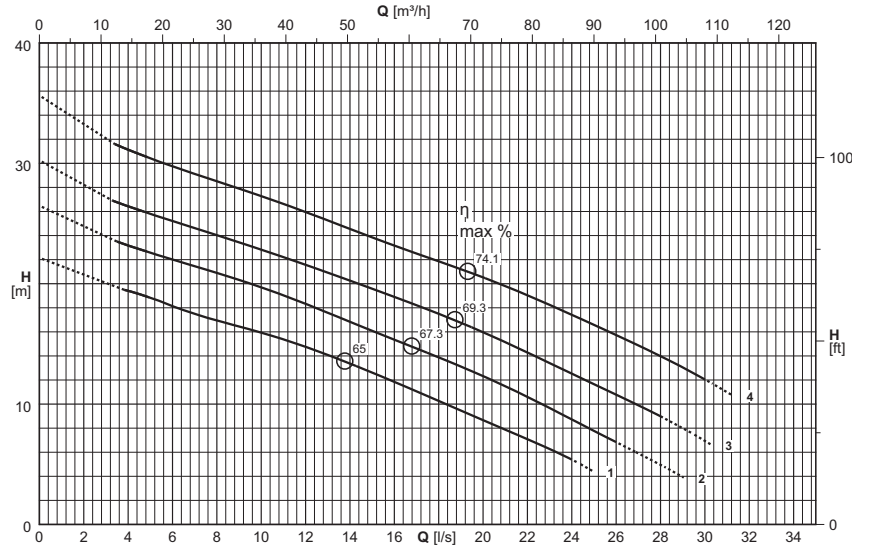

(1) = n°. of cables x (n°. of wires each cable x size [mm²]) x cable length [m] - Câble NSSHOU-J

Version+...21X3 Power supply:1x(7x1,5)x10

Cable length exceeding 10 m on request

(1) = n°. câbles x (n°. conducteurs câble x section [mm²]) x longueur câble [m] - Câble NSSHOU-J

Version+...21X3 Alimentation:1x(7x1,5)x10

Sur demande longueur de câble supérieure à 10 m

(1) = n°. cavi x (n°. conduttori per cavo x sezione [mm²]) x lunghezza cavo [m] - Cavo NSSHOU-J

Versione+...21X3 Alimentazione:1x(7x1,5)x10

Lunghezza cavo superiore a 10 m - su richiesta

Electric pump type Electropompe type Elettropompa tipo	Curve Courbe Curva	Motor power Puiss. moteur Potenza motore	Capacity Débit Portata																		
			[l/s]	0	4	5	6	7	8	9	10	12,5	15	17,5	20	22,5	25	27,5	30	31	
		P ₂	[m³/h]	0	14,4	18	21,6	25,2	28,8	32,4	36	45	54	63	72	81	90	99	108	111,6	
	(N°)	[kW]	Head Hauteur Prevalenza																		
KCA065HL+003821N3	1	3,8	[m]	22,2	19,4	18,8	18,1	17,5	17	16,4	15,9	14,4	12,6	10,7	8,7	6,7					
KCA065HG+003821N3	2	3,8	[m]	26,5	23,2	22,6	22	21,5	20,9	20,3	19,7	18	16,1	14,2	12,3	10,1	7,8	5,4			
KCA065HD+004821N3	3	4,8	[m]	30,3	26,4	25,8	25,2	24,6	24	23,4	22,8	21,2	19,6	17,9	16	13,8	11,7	9,4	6,9		
KCA065HA+006522N3	4	6,5	[m]	35,6	31,2	30,4	29,8	29,1	28,5	27,9	27,3	25,6	23,9	22,2	20,5	18,6	16,6	14,4	12	11	

P₂ = Power rated by the motor

Performance tolerance as per:
UNI/ISO 9906 Grade 3B

For motor performances specification see page "motor features"

For the accessories specification see page "Accessories"

The impellers will be trimmed to meet the duty point

P₂ = Puissance restituée par le moteur

Tolérances sur les performances selon normes:
UNI/ISO 9906 Niveau 3B

Pour caractéristiques techniques moteurs voir page "Caractéristiques des moteurs"

Pour les accessoires voir page "Accessories"

Le point de fonctionnement désiré peut être obtenu par rognage de roue

P₂ = Potenza resa dal motore

Tolleranze sulle prestazioni secondo norme:
UNI/ISO 9906 Grado 3B

Per caratteristiche motori vedere pagina "caratteristiche motori"

Per accessori vedere pagina accessori

Le giranti vengono tornite in modo da ottenere il punto di lavoro richiesto

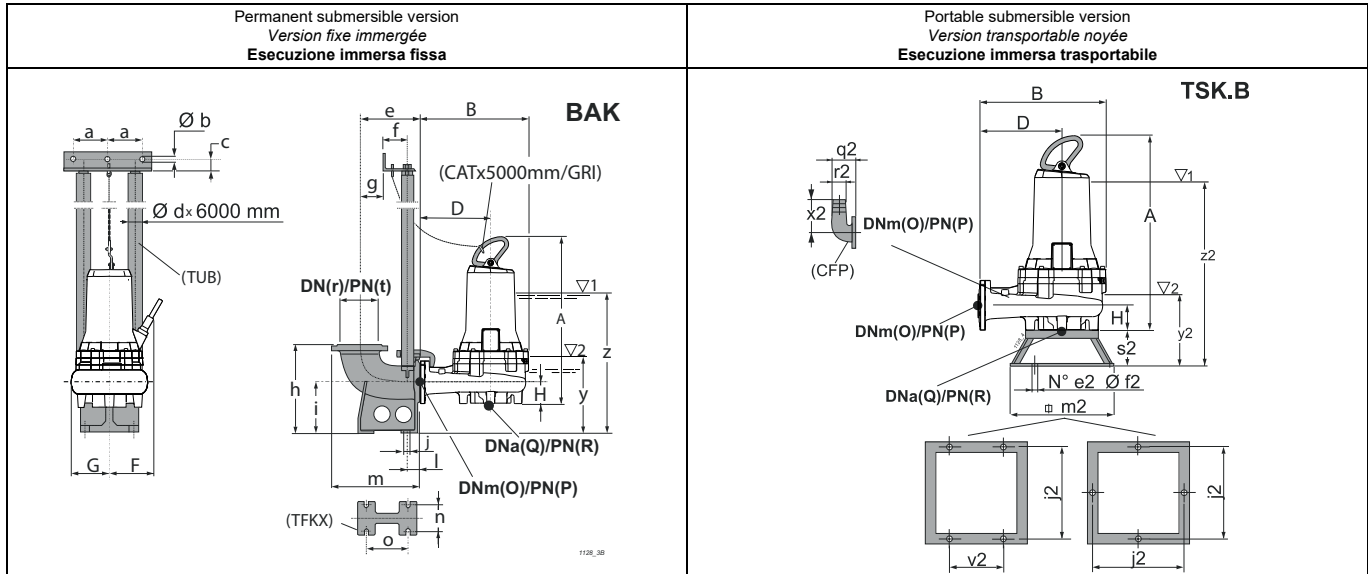

For fixed installation in a dry chamber - vertical (/R) <i>Pour installation fixe en fosse sèche - verticale (/R)</i> Esecuzione per camera asciutta - verticale (/R)	For fixed installation in a dry chamber - horizontal (/R) <i>Pour installation fixe en fosse sèche - horizontale (/R)</i> Esecuzione per camera asciutta - orizzontale (/R)
--	--

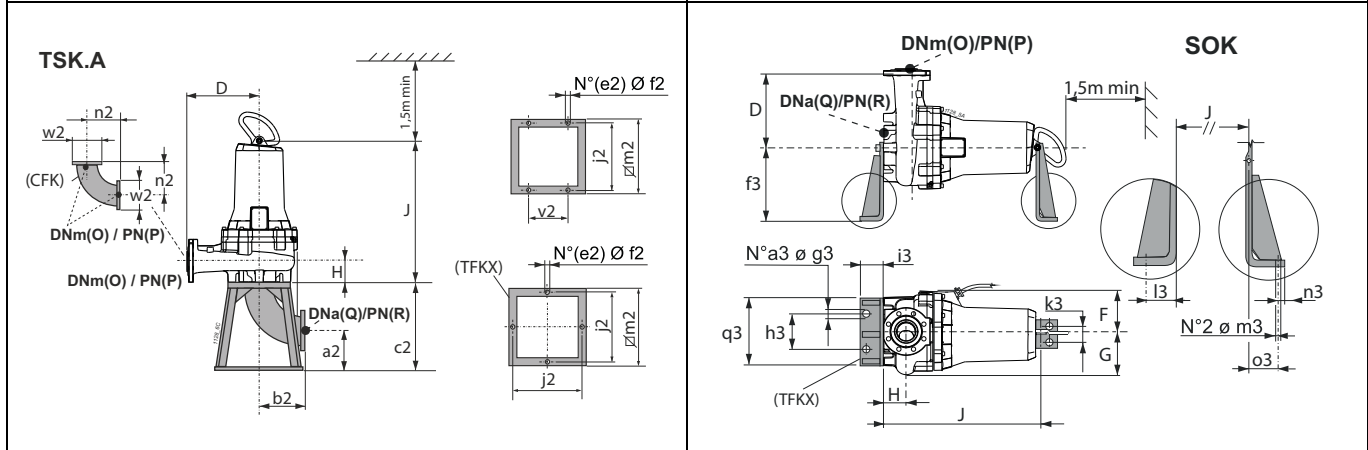

Type Type Tipo	Free passage Passage libre Passaggio Libero	Weight Poids Peso	A	B	D	F	G	H	J	O	P	Q	R	Accessories Accessoires Accessori			
			[mm]	[kg]	[mm]											BAK.	SOK.
KCA065HL+003821N3	---	81,69	608,8	390	245	145	221	91	523,5	65	16	65	16 (*)	F/E 2", F/E-A 2", E 2"	80/N3	K65	80
KCA065HG+003821N3	---	81,72	608,8	390	245	145	221	91	523,5	65	16	65	16 (*)	F/E 2", F/E-A 2", E 2"	80/N3	K65	80
KCA065HD+004821N3	---	81,75	608,8	390	245	145	221	91	523,5	65	16	65	16 (*)	F/E 2", F/E-A 2", E 2"	80/N3	K65	80
KCA065HA+006522N3	---	100,06	677,9	390	245	145	221	91	559,5	65	16	65	16 (*)	F/E 2", F/E-A 2", E 2"	80/N3	K65	80

BAK.	a	b	c	d	e	f	g	h	i	j	l	m	n	o	r	t	y	z
BAKF/E 2"	130	12,5	35	2"	220	102	40	280	160	18	47	320	110	156	80	ex PN10	270	595
BAKF/E-A 2"	130	12,5	35	2"	220	102	40	280	160	18	47	320	110	156	80	16	270	595
BAKE 2"	130	12,5	35	2"	220	102	40	280	160	18	47	312,5	110	156	65	16	270	595
SOK.	a3	f3	g3	h3	i3	k3	l3	m3	n3	o3	q3							
SOK80/N3	2	400	22	270	100	100	66	22	34	43	400							
TSK.A	a2	b2	c2	e2	f2	j2	m2	n2	v2	w2								
TSKK65A	150	140	290	4	12	390	440	140	230	185								
TSK.B	e2	f2	j2	m2	q2	r2	s2	v2	x2	y2	z2							
TSKB0B	4	12	400	440	135	75	166	230	200	367	692							

(3) z = Minimum submergence depth for motor without casing with continuous duty S1 (NPSHR permitting) (3) z = Immersion minimum pour moteur sans chemise en service continu S1 (compatible avec le NPSHR) (3) z = Immersion minima per motore senza mantello in funzione continuo S1 compatibilmente con l'NPSHR

y = Minimum submergence depth for motor without casing with intermittent duty S3 (NPSHR permitting) y = Immersion minimum pour moteur sans chemise en service intermittent S3 (compatible avec le NPSHR) y = Immersion minima con motore senza mantello in funzione intermittente S3 compatibilmente con l'NPSHR

(*) Consult the flanges page. (*) Voir page brides. (*) Vedere pagina flange.

The following are also available: Anchoring bolts, level regulators and Electric panels
Accessoires supplémentaires: Tire-fond, Régulateurs de niveau et coffres électriques
Sono inoltre disponibili: tirafondi, regolatori di livello e quadri elettrici

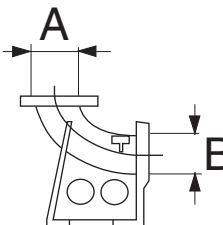
Duck-foot pedestal for automatic coupling (*) <i>Pied d'assise pour accouplement automatique (*)</i> Piede di accoppiamento automatico (*)	Type Type Tipo	A		B		Weight Poids Peso [Kg]	Electric pump type <i>Electropompe type</i> Elettropompa tipo				
		DN	UNI PN	DN	UNI PN		KCW065F	KCM065F	KCM065H	KCA065F	KCA065H
	BAKE 2"	65	16	65	16	21	•	•	•	•	•
	BAKF/E 2"	80	ex PN10	65	16	24	•	•	•	•	•
	BAKF/E-A 2"	80	16	65	16	24	•	•	•	•	•

(*) = Complete with:

Pump coupling bracket (nodular cast iron)

Rail pipes anchor bracket (stainless steel)

Screw and nuts

(*) = Composé de:

Support de guidage (fonte à graphite sphéroïdale)

Support de barre de guidage (acier inox)

Visserie

(*) = Completo di:

Staffa corpo premente (ghisa sferoidale)

Staffa per tubi guida (acciaio inox)



Minuteria

Rail pipes (*) (dipped galvanized steel) <i>Barres de guidage (*) (acier galvanisé à chaud)</i> Tubi guida (*) (acciaio zincato a caldo)	Type Type Tipo	Weight Poids Peso [Kg]	Electric pump type <i>Electropompe type</i> Elettropompa tipo				
			KCW065F	KCM065F	KCM065H	KCA065F	KCA065H
	TUB 2"	21	•	•	•	•	•

(*) = On demand: stainless steel

(*) = Sur demande: acier inox

(*) = Su richiesta: acciaio inox

Chain and Shackle Kit (*) <i>Kit Chaîne et manille (*)</i> Kit Catena e Grillo (*)	Type Type Tipo	Max load Portée max Portata max [Kg]	Length Longueur Lunghezza [m]	Electric pump type <i>Electropompe type</i> Elettropompa tipo				
				KCW065F	KCM065F	KCM065H	KCA065F	KCA065H
CAT  GRI 	CAT D.6 / GRL D.8	140	5	•	•	•	•	•

(*) = On demand: stainless steel

(*) = Sur demande: acier inox

(*) = Su richiesta: acciaio inox

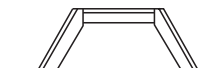
Base frame (dipped galvanized steel) <i>Chassis de soutien (acier galvanisé)</i> Telaio di sostegno (acciaio zincato a caldo)	Type Type Tipo	Weight Poids Peso [Kg]	Electric pump type <i>Electropompe type</i> Elettropompa tipo				
			KCW065F	KCM065F	KCM065H	KCA065F	KCA065H
	TSK80B	8,5	-	-	•	-	•

Flanged hose connection (dipped galvanized steel) <i>Coude pour tuyauterie souple (acier galvanisé à chaud)</i> Curva flangiata portagomma (acciaio zincato a caldo)	Type Type Tipo	Weight Poids Peso [Kg]	Electric pump type <i>Electropompe type</i> Elettropompa tipo				
			KCW065F	KCM065F	KCM065H	KCA065F	KCA065H
	CFP65	5	•	•	•	•	•

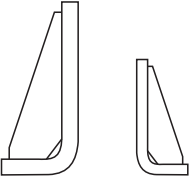
Supports (Steel with protective paint) Support de soutien (Acier revêtu de peinture de protection) Supporti (acciaio con vernice protettiva)	Type Type Tipo	Weight Poids Peso	Electric pump type Electropompe type Elettropompa tipo				
		[Kg]	KCW065F	KCM065F	KCM065H	KCA065F	KCA065H
	SOK80/N3	26,5	-	-	3,8-4,8	-	3,8-4,8-6,5

Handle in stainless steel (*) Manille de soulèvement en acier inox (*) Maniglia di aggancio in acciaio inox (*)	Type Type Tipo	Weight Poids Peso	Electric pump type Electropompe type Elettropompa tipo				
		[Kg]	KCW065F	KCM065F	KCM065H	KCA065F	KCA065H
	MAN-235/3	0,5	•	•	-	•	-

(*) = Complete with screw and bolts

(*) = Complète de visserie

(*) = Completa di minuteria

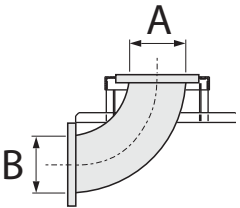
Base frame (dipped galvanized steel) Chassis de soutien (acier galvanisé) Telaio di sostegno (acciaio zincato a caldo)	Type Type Tipo	A		B		Weight Poids Peso [Kg]	Electric pump type Electropompe type Elettropompa tipo				
		DN	UNI PN	DN	UNI PN		KCW065F	KCM065F	KCM065H	KCA065F	KCA065H
	TSKK65A	65	16 (*)	65	16 (*)	14,5	-	-	•	-	•

(*) = Fixed installation in a dry chamber

(*) = Installation fixe en fosse

(*) = Esecuzione per camera asciutta

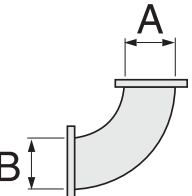
Flanged elbow (dipped galvanized steel) Coude bridé (acier galvanisé à chaud) Curva flangiata (acciaio zincato a caldo)	Type Type Tipo	A		B		Weight Poids Peso [Kg]	Electric pump type Electropompe type Elettropompa tipo				
		DN	UNI PN	DN	UNI PN		KCW065F	KCM065F	KCM065H	KCA065F	KCA065H
	CFK65	65	16	65	16	2	-	-	•	-	•

50 Hz motor features (*N/X)
Caractéristiques des moteurs à 50 Hz (*N/X)
Caratteristiche motori a 50 Hz (*N/X)

Poles Pôles Poli	Motor type Moteur type Motore tipo	Motor power Puiss. moteur Potenza motore		Absorption Intensité Assorbimento	Direct starting Démarrage direct Avviamento diretto	Direct starting2 Démarrage direct2 Avviamento diretto2		Starts / hour max Max démarrages / heure Max avviamenti/ora	Degree of intermittence Degré d'intermittence Grado di intermittenza
		P ₁	P ₂	IN (400V)		(Standard)			
		[kW]		[A]		I _S /I _N	Direct Direct Diretto		
4	KC00164..F100..	1,89	1,6	3,7	6,6	●		20	30
	KC00214..F100..	2,46	2,1	5,1	7,7	●		20	30
	KC00264..F100..	3	2,6	5,8	6,8	●		20	30
2	KC00202..F090..	2,37	2	4,1	6,9	●		20	30
	KC00252..F090..	2,96	2,5	5,5	8,9	●		20	40
	KC00312..F100..	3,53	3,1	5,6	8,5	●		20	40
	KC00382..H112..	4,32	3,8	7,5	10,9	●		20	25
	KC00482..H112..	5,5	4,8	8,9	9,2	●		20	25
	KC00652..H132..	7,34	6,5	11,9	9,2	●	●	15	30

*N = Standard version

*X = Explosion-proof version

P₁ = Power absorbed by the motor

P₂ = Power rated by the motor

I_N = Rated current

I_S = Starting current

- The electric pumps are suitable for S1 continuous service with submersed motor and for S3 intermittent service (see relative degrees of intermittence in the table) with non-submersed motor.

S3 service stands for intermittent service consisting of 10 minute equal cycles of which the previous table indicates the minutes of the cycle during which the motor may operate (eg. : S3 = 25%. operation consists of a repetitive sequence of 2,5 minutes operation and 7,5 minutes at a standstill). See standard CEI EN 60034-1

- The electric motors are produced in the following voltage ratings: 400 V ± 10% standard; 230 V ± 10% on request.

Other voltages on request.

*N = Version standard

*X = Version antidéflagrante

P₁ = Puissance absorbée par le moteur

P₂ = Puissance restituée par le moteur

I_N = Intensité nominale

I_S = Intensité au démarrage

- L'électropompe est apte à fonctionner en service continu S1 avec le moteur complètement immergé, en service intermittent S3 moteur non immergé (se reporter aux valeurs d'intermittence mentionnées dans le tableau).

Le service S3 indique un fonctionnement intermittent par cycles identiques de 10 minutes. Le tableau ci-dessus indique le temps de marche du moteur en minutes pour 1 cycle de 10 minutes (Ex. : S3 = 25% chaque cycle sera composé de 2,5 minutes de marche et de 7,5 minutes d'arrêt). Voir norme CEI EN 60034-1.

- Les moteurs électriques prévus doivent être alimentés aux tensions nominales suivantes: 400 V ± 10% standard; 230 V ± 10% sur demande.

Tensions différentes sur demande.

*N = Versione standard

*X = Versione antideflagrante

P₁ = Potenza assorbita motore

P₂ = Potenza resa dal motore

I_N = Corrente nominale

I_S = Corrente di avviamento

- Le elettropompe sono atte a funzionare in servizio continuo S1 con motore immerso, in servizio intermittente S3 con motore non immerso (vedi relativi gradi di intermittenza nella tabella).

Il servizio S3 sta ad indicare un funzionamento intermittente composto da cicli tutti uguali di 10 minuti di cui si indicano i minuti del ciclo in cui il motore può funzionare (Es. : S3 = 25% il funzionamento è composto da una sequenza ripetitiva di 2,5 minuti di funzionamento e di 7,5 minuti di sosta). Vedi norma CEI EN 60034-1.

- I motori elettrici sono previsti per essere alimentati alle seguenti tensioni nominali di rete: 400 V ± 10% standard; 230 V ± 10% a richiesta.

Tensioni diverse su richiesta.

K+ DN 80÷200



- KCW080H
- KCW080L
- KCW100H
- KCW100L
- KCM080F
- KCM080H
- KCM080L
- KCM100H
- KCM150H
- KCM150L
- KCD200N+
- 00756..6P
- KCA080H
- KCA080L
- KCA100H
- KCA100L
- KCA150H

Performance ranges
Champs de performance
Campi di prestazione

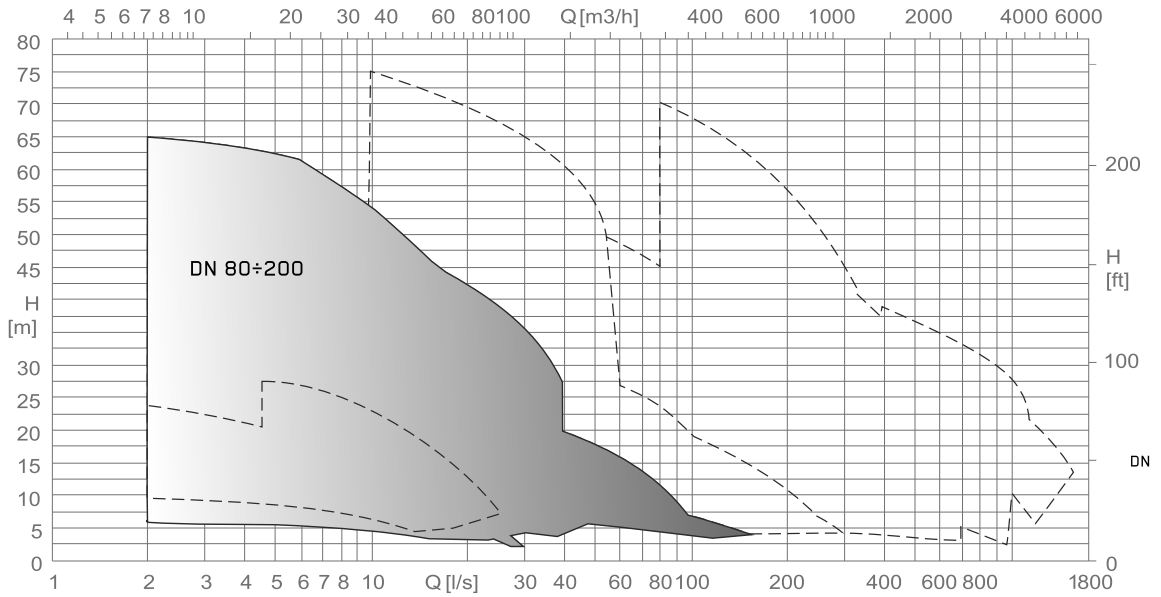

[Imp.g.p.m.]



[US.g.p.m.]



[l/min]



K+ DN 80÷200

caprari

KCW080H
KCW080L
KCW100H
KCW100L
KCM080H
KCM080L
KCM100H
KCM150H
KCM150L
KCD200N+
00756..6P

Construction and materials
Construction et matériaux
Costruzione e materiali

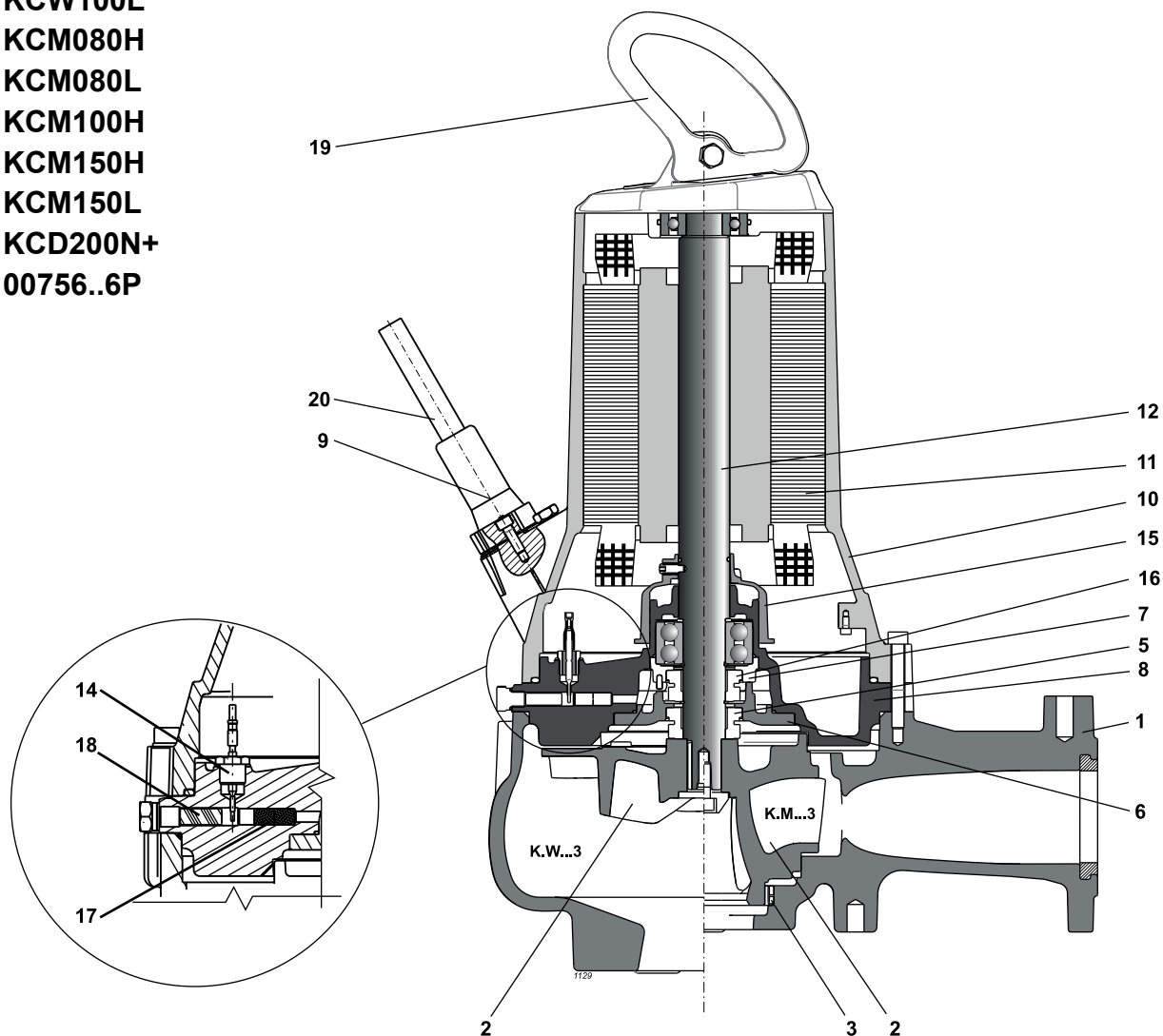

Pos.	Parts	Materials	Nomenclature	Matériaux	Nomenclatura	Materiale
1	Delivery body	Cast iron	Corps de refoulement	Fonte grise	Corpo mandata	Ghisa grigia
2	Impeller	Cast iron	Roue	Fonte grise	Girante	Ghisa grigia
3	Impeller wear ring	-	Bague d'usure	-	Anello sede girante	-
5	Mechanical seal on pump side	silicon carbide/ceramic	Garniture mécanique côté pompe	carbure de silicium/céramique	Tenuta meccanica lato pompa	Carburo di silicio/ceramica
6	Flange for mechanical seal	Nodular cast iron	Bride porte garniture mécanique	Fonte sphéroïdale	Flangia porta tenuta meccanica	Ghisa sferoidale
7	Support bearing	Cast iron	Support de roulement	Fonte grise	Supporto cuscinetto	Ghisa grigia
8	Oil box	Cast iron	Chambre à huile	Fonte grise	Scatola olio	Ghisa grigia
9	Cable clamp	Stainless steel	Presse-étoupe	Acier inox	Pressacavo	Acciaio inox
10	Motor casing	Cast iron	Enveloppe du moteur	Fonte grise	Carcassa motore	Ghisa grigia
11	Stator	Electrical steel	Stator	Tôle magnétique	Statore	Lamierino magnetico
12	Complete shaft with rotor	Stainless steel/ Magnetic steel	Arbre avec rotor	Acier inox/Tôle magnétique	Albero completo di rotore	Acciaio inox/ Lamierino magnetico
14	Conductivity probe	-	Sondes de conductivité	-	Sonda di conduttività	-
15	Oil centrifuge	Technopolymer	Centrifugeur huile	Polymère technique	Centrifugatore olio	Tecnopolimero
16	Mechanical seal on motor side	Ceramic/graphite	Garniture mécanique côté moteur	Céramique/graphite	Tenuta meccanica lato motore	Ceramica/grafite
17	Flame arrester	Stainless steel	Arrête-Flamme	Acier inox	Arrestatore di fiamma	Acciaio inox
18	Diaphragm	Nitrile rubber	Membrane	Caoutchouc nitrile	Membrana	Gomma nitrilica
19	Handle	Stainless steel	Poignée	Acier inox	Maniglia	Acciaio inox
20	Round power cable	-	Câble rond d'alimentation	-	Cavo tondo di alimentazione	-

Screws and nuts in stainless steel.
Available version with AISI 316 stainless steel impeller.

Vis et écrous en acier inox
Disponible version Avec roue en acier inox AISI 316.

Viti e dadi in acciaio inox
Disponibile versione con girante in acciaio inox AISI 316.

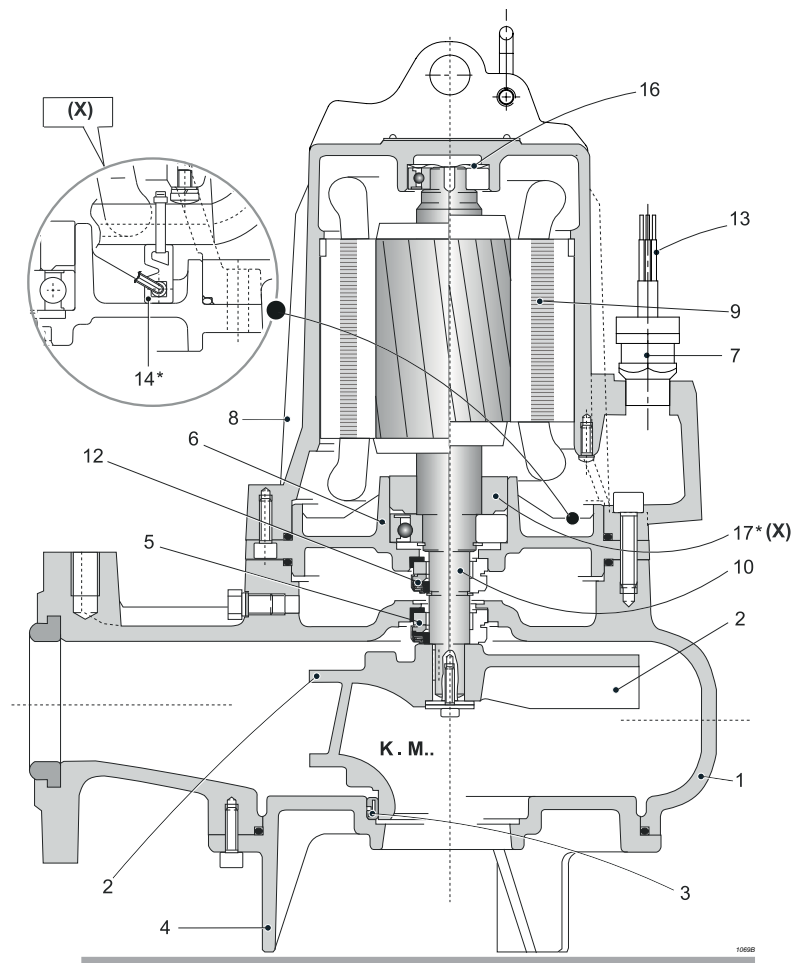

Pos.	Parts	Materials	Nomenclature	Matériaux	Nomenclatura	Materiale
1	Delivery body	Cast iron	Corps de refoulement	Fonte grise	Corpo mandata	Ghisa grigia
2	Impeller	Cast iron	Roue	Fonte grise	Girante	Ghisa grigia
3	Impeller wear ring	Steel/Rubber	Bague d'usure	Acier/Caoutchouc	Anello sede girante	Acciaio/Gomma
4	Suction support	Cast iron	Palier aspiration	Fonte grise	Supporto aspirazione	Ghisa grigia
5	Mechanical seal on pump side	silicon carbide/ceramic	Garniture mécanique côté pompe	carbure de silicium/céramique	Tenuta meccanica lato pompa	Carburo di silicio/ceramica
6	Support bearing	Nodular cast iron	Support de roulement	Fonte sphéroïdale	Supporto cuscinetto	Ghisa sferoidale
7	Cable clamp	Brass	Presse-étoupe	Laiton	Pressacavo	Ottone
8	Motor casing	Cast iron	Enveloppe du moteur	Fonte grise	Carcassa motore	Ghisa grigia
9	Stator	Electrical steel	Stator	Tôle magnétique	Statore	Lamierino magnetico
10	Complete shaft with rotor	Stainless steel/ Magnetic steel	Arbre avec rotor	Acier inox/Tôle magnétique	Albero completo di rotore	Acciaio inox/ Lamierino magnetico
12	Mechanical seal on motor side	Ceramic/graphite	Garniture mécanique côté moteur	Céramique/graphite	Tenuta meccanica lato motore	Ceramica/grafite
13	Round power cable	-	Câble rond d'alimentation	-	Cavo tondo di alimentazione	-
14*	Conductivity probe	-	Sondes de conductivité	-	Sonda di conduttività	-
16	Elastic ring	Stainless steel	Circlip	Acier inox	Anello elastico	Acciaio inox
17*	Spacer sleeve	Steel	Entretoise	Acier	Distanziale	Acciaio
18	Handle (upon request)	Stainless steel	Poignée (sur demande)	Acier inox	Maniglia (su richiesta)	Acciaio inox

* For explosion-proof versions (X);
On demand for (N) versions.
(Conductivity probe in the motor casing)
Screws and nuts in stainless steel.
Available version with AISI 316 stainless steel impeller.

* Pour version antidéflagrantes (X);
Sur demande pour les versions (N).
(Sonde de conductivité dans l'enveloppe du moteur)
Vis et écrous en acier inox
Disponible version Avec roue en acier inox AISI 316.

* Per versioni antideflagranti (X);
su richiesta per versioni (N).
(Sonda di conduttività nella carcassa motore)
Viti e dadi in acciaio inox
Disponibile versione con girante in acciaio inox AISI 316.

K+

DN 80÷200

caprari

Construction and materials
Construction et matériaux
Costruzione e materiali

KCA080H
KCA080L
KCA100H
KCA100L
KCA150H

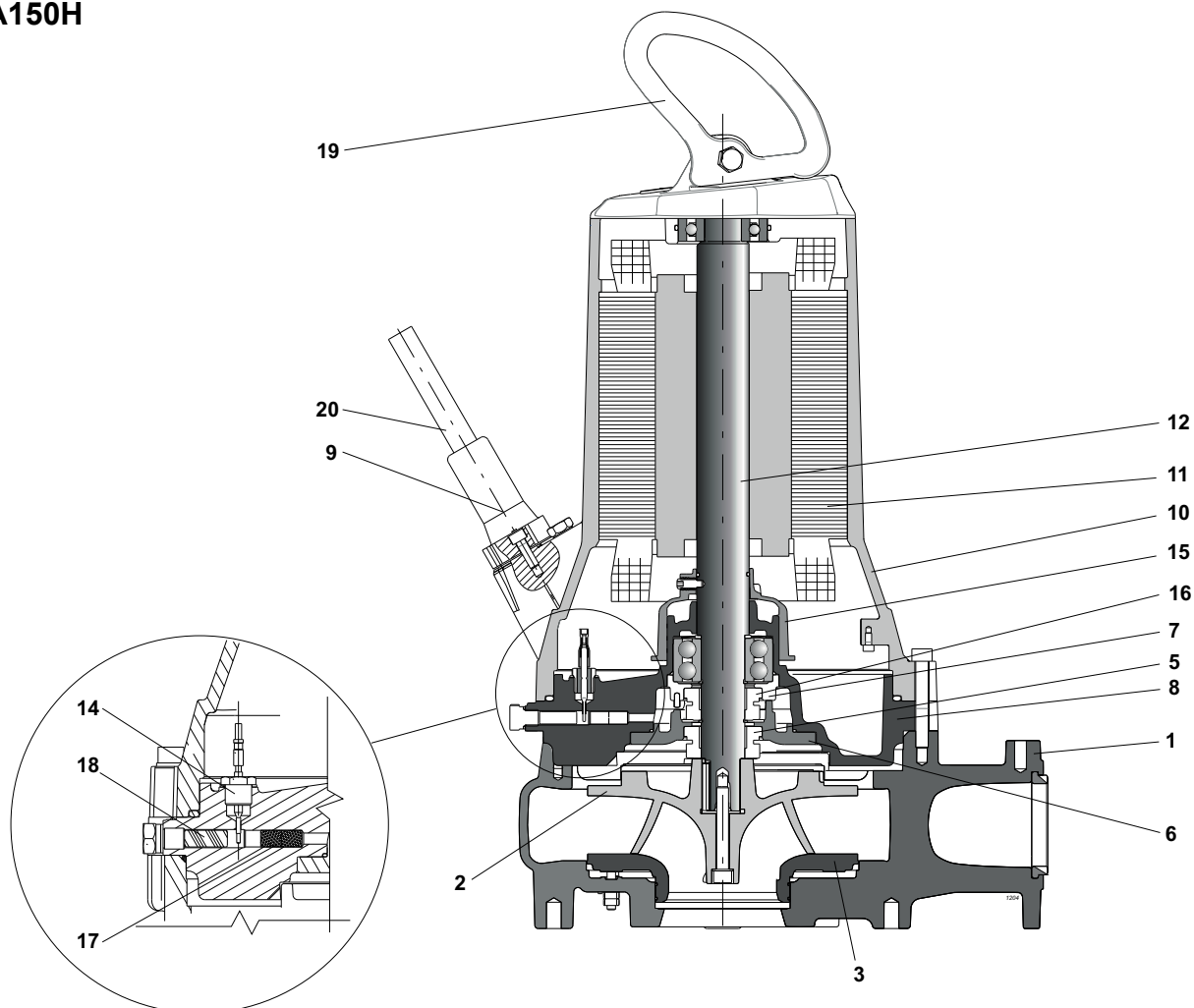

Pos.	Parts	Materials	Nomenclature	Matériaux	Nomenclatura	Materiale
1	Delivery body	Cast iron	Corps de refoulement	Fonte grise	Corpo mandata	Ghisa grigia
2	Impeller	Cast iron	Roue	Fonte grise	Girante	Ghisa grigia
3	Suction support	Nodular cast iron	Palier aspiration	Fonte sphéroïdale	Supporto aspirazione	Ghisa sferoidale
5	Mechanical seal on pump side	silicon carbide/ceramic	Garniture mécanique côté pompe	carbure de silicium/ céramique	Tenuta meccanica lato pompa	Carburo di silicio/ ceramica
6	Flange for mechanical seal	Nodular cast iron	Bride porte garniture mécanique	Fonte sphéroïdale	Flangia porta tenuta meccanica	Ghisa sferoidale
7	Support bearing	Cast iron	Support de roulement	Fonte grise	Supporto cuscinetto	Ghisa grigia
8	Oil box	Cast iron	Chambre à huile	Fonte grise	Scatola olio	Ghisa grigia
9	Cable clamp	Stainless steel	Presse-étoupe	Acier inox	Pressacavo	Acciaio inox
10	Motor casing	Cast iron	Enveloppe du moteur	Fonte grise	Carcassa motore	Ghisa grigia
11	Stator	Electrical steel	Stator	Tôle magnétique	Statore	Lamierino magnetico
12	Complete shaft with rotor	Stainless steel/ Magnetic steel	Arbre avec rotor	Acier inox/Tôle magnétique	Albero completo di rotore	Acciaio inox/ Lamierino magnetico
14	Conductivity probe	-	Sondes de conductivité	-	Sonda di conduttività	-
15	Oil centrifuge	Technopolymer	Centrifugeur huile	Polymère technique	Centrifugatore olio	Tecnopolimero
16	Mechanical seal on motor side	Ceramic/graphite	Garniture mécanique côté moteur	Céramique/graphite	Tenuta meccanica lato motore	Ceramica/grafite
17	Flame arrester	-	Arrête-Flamme	-	Arrestatore di fiamma	-
18	Diaphragm	Nitrile rubber	Membrane	Caoutchouc nitrile	Membrana	Gomma nitrilica
19	Handle	Stainless steel	Poignée	Acier inox	Maniglia	Acciaio inox
20	Round power cable	-	Câble rond d'alimentation	-	Cavo tondo di alimentazione	-

Screws and nuts in stainless steel.

Available version with AISI 316 stainless steel impeller.

Vis et écrous en acier inox

Disponibile version Avec roue en acier inox AISI 316.

Viti e dadi in acciaio inox

Disponibile versione con girante in acciaio inox AISI 316.

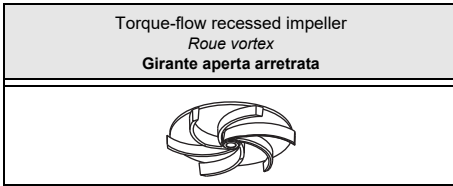

Type Type Tipo	KCW080H...+...61N3	KCW080H...+...61X3
Thermal probes Sondes termiques Sonde termiche	Yes Oui Sì	Yes Oui Sì
Conductivity probe Sonde de conductivité Sonda di conduttività	Yes Oui Sì	Yes Oui Sì

Version cable (1)
Version câble (1)
Cavo Versione (1)

Electric pump type <i>Electropompe type</i> Elettropompa tipo	Power supply <i>Alimentation</i> Alimentazione	Auxiliary <i>Auxiliaire</i> Ausiliario
KCW080HP+001561N3	1x(7x1,5)x10	
KCW080HM+001561N3	1x(7x1,5)x10	
KCW080HI+001561N3	1x(7x1,5)x10	
KCW080HE+001561N3	1x(7x1,5)x10	
KCW080HA+001561N3	1x(7x1,5)x10	

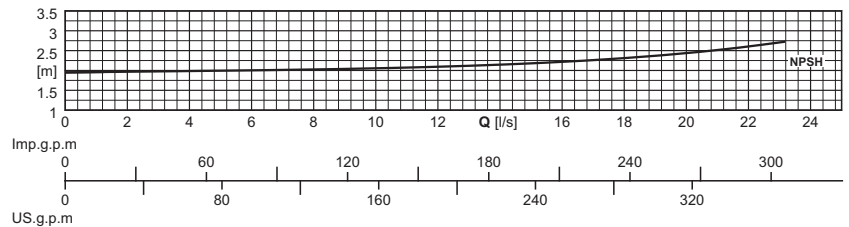
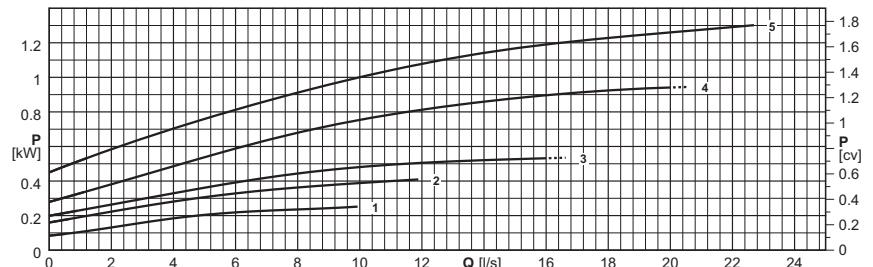
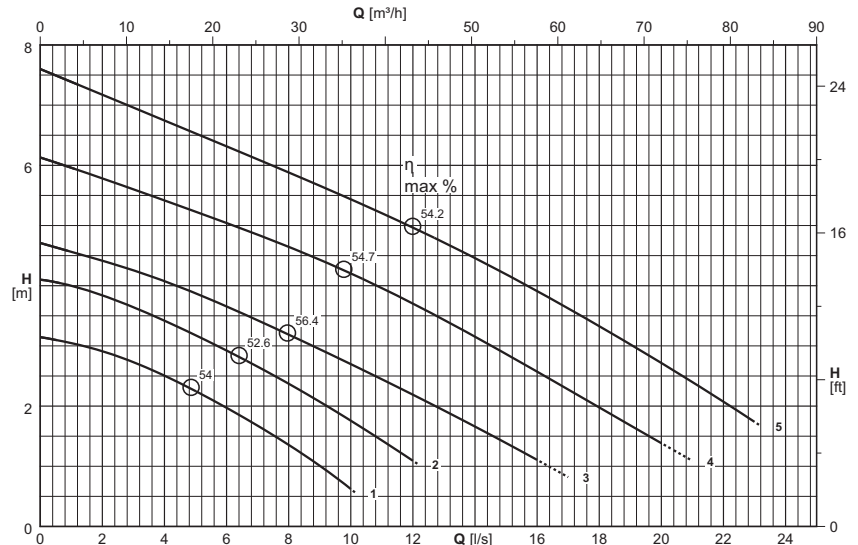

(1) = n°. of cables x (n°. of wires each cable x size [mm²]) x cable length [m] - Cable NSSHÖU-J

Cable length exceeding 10 m on request

(1) = n°. câbles x (n°. conducteurs câble x section [mm²]) x longueur câble [m] - Câble NSSHÖU-J

Sur demande longueur de câble supérieure à 10 m

(1) = n°. cavi x (n°. conduttori per cavo x sezione [mm²]) x lunghezza cavo [m] - Cavo NSSHÖU-J

Lunghezza cavo superiore a 10 m - su richiesta

Electric pump type <i>Electropompe type</i> Elettropompa tipo	Curve <i>Courbe</i> Curva	Motor power <i>Puiss. moteur</i> Potenza motore	Capacity <i>Debit</i> Portata																
			[l/s]	0	0,6	0,8	1	2	3	4	5	6	7	8	9	10	15	20	23
		P ₂	[m ³ /h]	0	2,2	2,9	3,6	7,2	10,8	14,4	18	21,6	25,2	28,8	32,4	36	54	72	82,8
	(N°)	[kW]																	
KCW080HP+001561N3	1	1,5	[m]	3,1	3,1	3,1	3	2,9	2,7	2,5	2,2	2	1,7	1,4	1	0,6			
KCW080HM+001561N3	2	1,5	[m]	4,1	4	4	4	3,8	3,6	3,4	3,2	2,9	2,7	2,4	2,1	1,8			
KCW080HI+001561N3	3	1,5	[m]	4,7	4,6	4,6	4,6	4,4	4,3	4,1	3,9	3,7	3,4	3,2	2,9	2,7	1,4		
KCW080HE+001561N3	4	1,5	[m]	6,1	6	6	6	5,8	5,6	5,4	5,2	5	4,8	4,6	4,4	4,2	2,9	1,4	
KCW080HA+001561N3	5	1,5	[m]	7,6	7,5	7,4	7,4	7,2	7	6,7	6,5	6,3	6,1	5,9	5,7	5,4	4,2	2,7	1,7
NPSH _R			[m]					2	2	2	2	2	2	2	2	2,1	2,2	2,4	2,7

P₂ = Power rated by the motor

Performance tolerance as per:
UNI/ISO 9906 Grade 3B

For motor performances specification see page "motor features"

For the accessories specification see page "Accessories"

The impellers will be trimmed to meet the duty point

P₂ = Puissance restituée par le moteur

Tolérances sur les performances selon normes:
UNI/ISO 9906 Niveau 3B

Pour caractéristiques techniques moteurs voir page "Caractéristiques des moteurs"

Pour les accessoires voir page "Accessories"

Le point de fonctionnement désiré peut être obtenu par rognage de roue

P₂ = Potenza resa dal motore

Tolleranze sulle prestazioni secondo norme:
UNI/ISO 9906 Grado 3B

Per caratteristiche motori vedere pagina "caratteristiche motori"

Per accessori vedere pagina accessori

Le giranti vengono tornite in modo da ottenere il punto di lavoro richiesto

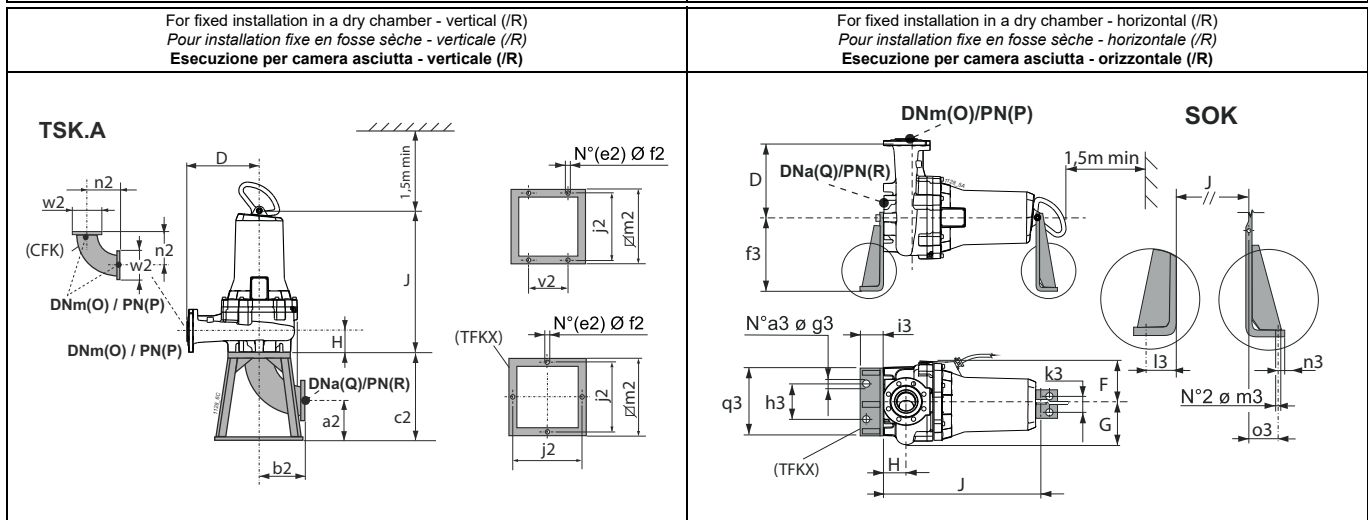
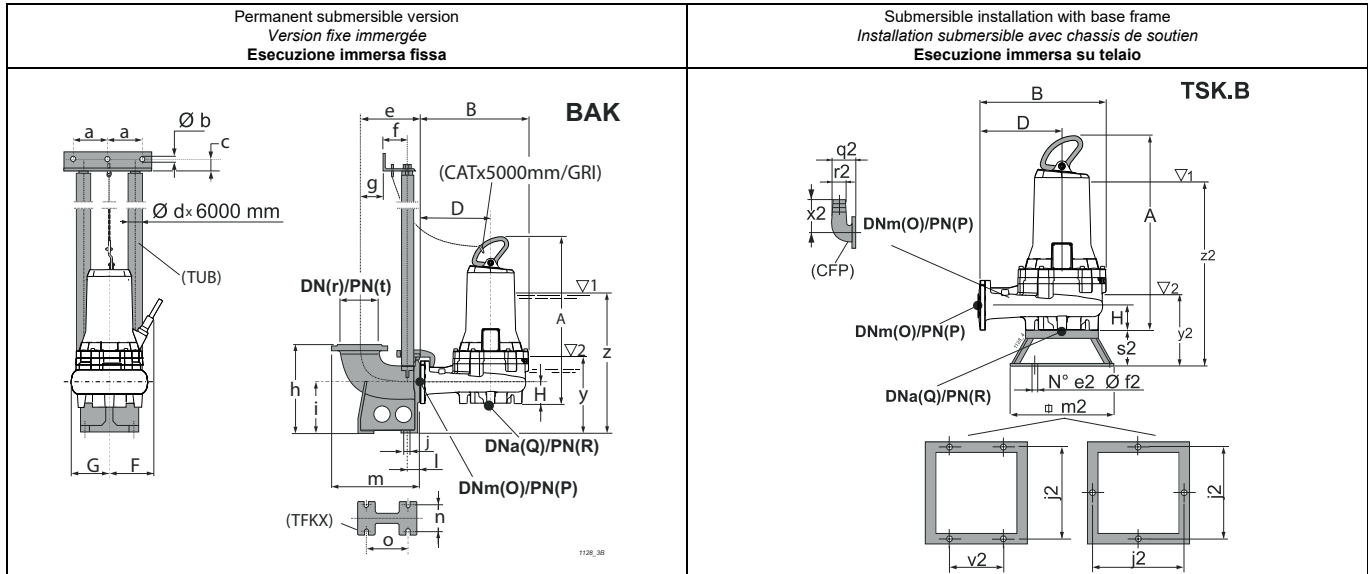

Type Type Tipo	Free passage Passage libre Passaggio Libero	Weight Poids Peso	A	B	D	F	G	H	J	O	P	Q	R	Accessories Accessoires Accessori			
			[mm]	[kg]	[mm]											BAK.	SOK.
KCW080HP+001561N3	Ø 80	83,6	638,3	392	245	204,5	146	92	553	80	16	80	16 (*)	F 2", G/F 2", F-A 2"	80/N3	K80	80
KCW080HM+001561N3	Ø 80	84,5	638,3	392	245	204,5	146	92	553	80	16	80	16 (*)	F 2", G/F 2", F-A 2"	80/N3	K80	80
KCW080HI+001561N3	Ø 80	81,6	638,3	392	245	204,5	146	92	553	80	16	80	16 (*)	F 2", G/F 2", F-A 2"	80/N3	K80	80
KCW080HE+001561N3	Ø 80	86,6	638,3	392	245	204,5	146	92	553	80	16	80	16 (*)	F 2", G/F 2", F-A 2"	80/N3	K80	80
KCW080HA+001561N3	Ø 80	82,7	638,3	392	245	204,5	146	92	553	80	16	80	16 (*)	F 2", G/F 2", F-A 2"	80/N3	K80	80

BAK.	a	b	c	d	e	f	g	h	i	j	l	m	n	o	r	y	z	
BAKF 2"	130	12,5	35	2"	220	102	40	320	180	18	47	320	110	156	80	277	495	
BAKG/F 2"	130	12,5	35	2"	228	102	48	320	180	18	47	338	110	156	100	16	277	495
BAKF-A 2"	130	12,5	35	2"	220	102	40	320	180	18	47	320	110	156	80	16	277	495

SOK.	a3	f3	g3	h3	i3	k3	l3	m3	n3	o3	q3
SOK80/N3	2	400	22	270	100	100	66	22	34	43	400

TSK.A	a2	b2	c2	e2	f2	j2	m2	n2	v2	w2
TSKK80A	126	164	290	4	12	390	440	164	230	200

TSK.B	e2	f2	j2	m2	q2	r2	s2	v2	x2	y2	z2
TSK80B	4	12	400	440	165	75	166	230	217	355	573

(3) z = Minimum submergence depth for motor without casing with continuous duty S1 (NPSHR permitting) (3) z = Immersion minimum pour moteur sans chemise en service continu S1 (compatible avec le NPSHR) (3) z = Immersion minima per motore senza mantello in funzione continuo S1 compatibilmente con l'NPSHR

y = Minimum submergence depth for motor without casing with intermittent duty S3 (NPSHR permitting) y = Immersion minimum pour moteur sans chemise en service intermittent S3 (compatible avec le NPSHR) y = Immersion minima con motore senza mantello in funzione intermittente S3 compatibilmente con l'NPSHR

(*) Consult the flanges page. (*) Voir page brides. (*) Vedere pagina flange.

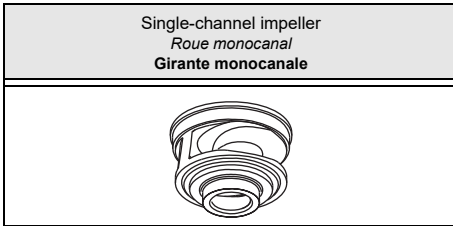

Type Type Tipo	KCM080H...+...61N3	KCM080H...+...61X3
Thermal probes Sondes thermiques Sonda termiche	Yes Oui Sì	Yes Oui Sì
Conductivity probe Sonde de conductivité Sonda di conduttività	Yes Oui Sì	Yes Oui Sì

Version cable (1)
Version câble (1)
Cavo Versione (1)

Electric pump type Electropompe type Elettropompa tipo	Power supply Alimentation Alimentazione	Auxiliary Auxiliaire Ausiliario
KCM080HG+001561N3	1x(7x1,5)x10	
KCM080HD+001561N3	1x(7x1,5)x10	
KCM080HA+001561N3	1x(7x1,5)x10	

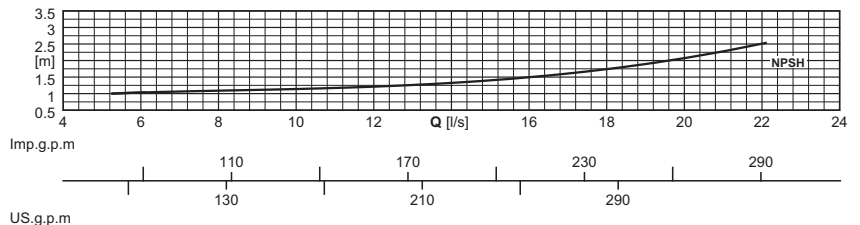
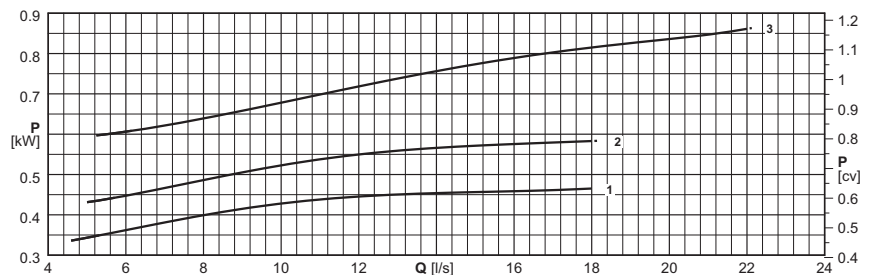
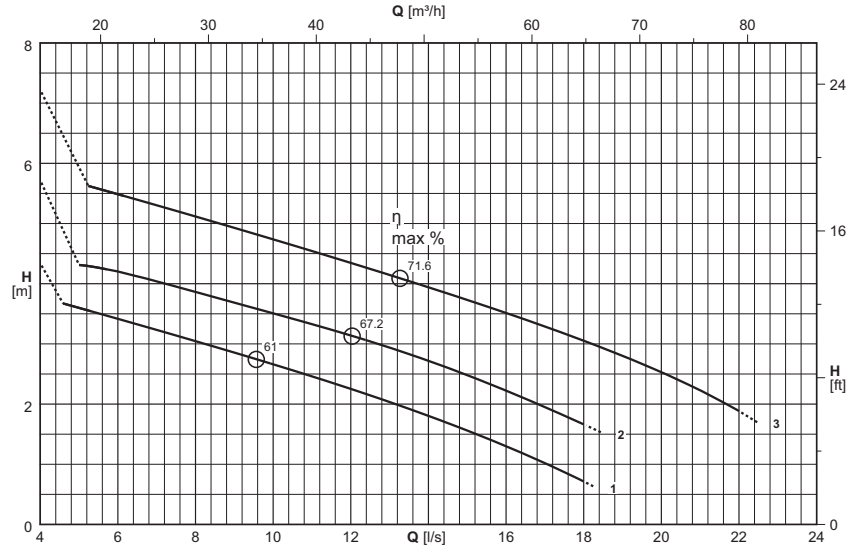

(1) = n°. of cables x (n°. of wires each cable x size [mm²]) x cable length [m] - Câble NSSHOU-J

Cable length exceeding 10 m on request

(1) = n°. câbles x (n°. conducteurs câble x section [mm²]) x longueur câble [m] - Câble NSSHOU-J

Sur demande longueur de câble supérieure à 10 m

(1) = n°. cavi x (n°. conduttori per cavo x sezione [mm²]) x lunghezza cavo [m] - Cavo NSSHOU-J

Lunghezza cavo superiore a 10 m - su richiesta

Electric pump type Electropompe type Elettropompa tipo	Curve Courbe Curva	Motor power Puiss. moteur Potenza motore	Capacity Débit Portata																
			[l/s]	0	5	6	7	8	9	10	12	14	16	18	20	22			
			P ₂	[m ³ /h]	0	18	21,6	25,2	28,8	32,4	36	43,2	50,4	57,6	64,8	72	79,2		
			(N°)	[kW]	Head Hauteur Prevalenza														
			[m]	[m]	4,3	3,6	3,4	3,2	3	2,9	2,7	2,3	1,8	1,3	0,7				
KCM080HG+001561N3	1	1,5		[m]	4,3	3,6	3,4	3,2	3	2,9	2,7	2,3	1,8	1,3	0,7				
KCM080HD+001561N3	2	1,5		[m]	5,7	4,3	4,2	4	3,9	3,7	3,5	3,1	2,7	2,2	1,7				
KCM080HA+001561N3	3	1,5		[m]	7,2		5,5	5,3	5,1	4,9	4,7	4,3	3,9	3,5	3,1	2,5	1,9		
NPSH _R				[m]			1	1,1	1,1	1,1	1,1	1,2	1,3	1,5	1,7	2,1	2,5		

P₂ = Power rated by the motor

Performance tolerance as per: UNI/ISO 9906 Grade 3B

For motor performances specification see page "motor features"

For the accessories specification see page "Accessories"

P₂ = Puissance restituée par le moteur

Tolérances sur les performances selon normes: UNI/ISO 9906 Niveau 3B

Pour caractéristiques techniques moteurs voir page "Caractéristiques des moteurs"

Pour les accessoires voir page "Accessories"

P₂ = Potenza resa dal motore

Tolleranze sulle prestazioni secondo norme: UNI/ISO 9906 Grado 3B

Per caratteristiche motori vedere pagina "caratteristiche motori"

Per accessori vedere pagina accessori

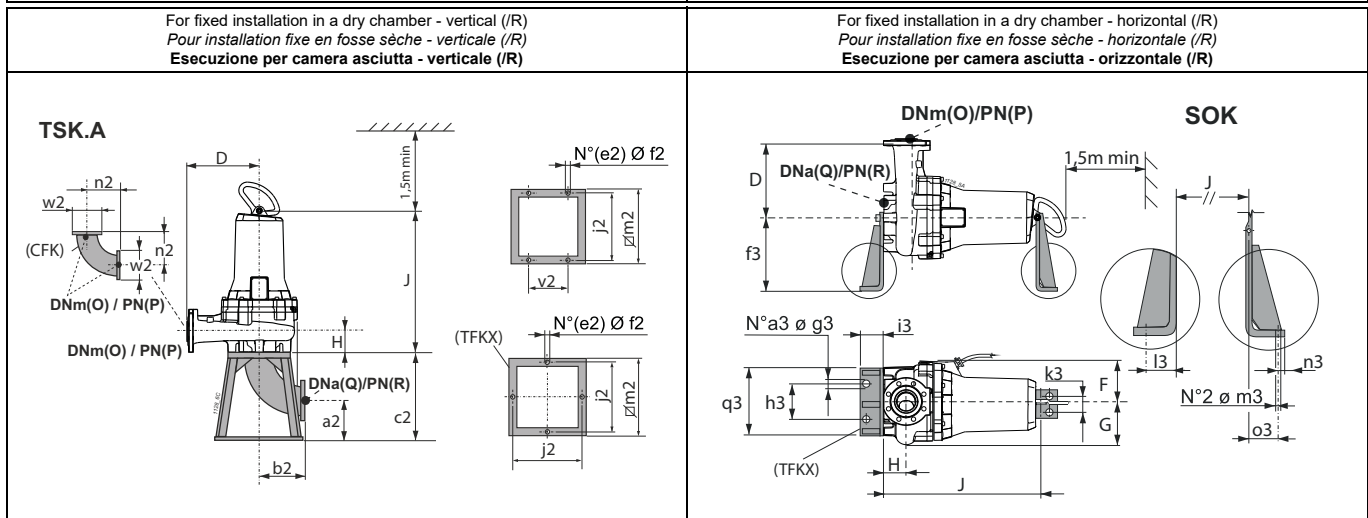
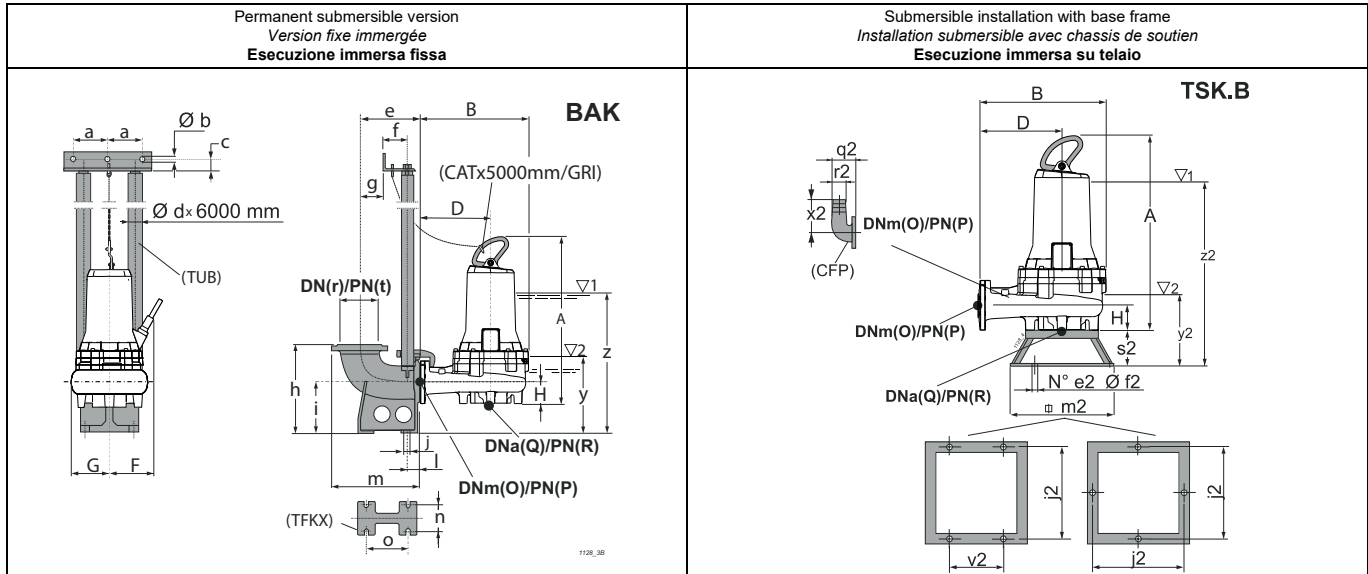

Type Type Tipo	Free passage Passage libre Passaggio Libero	Weight Poids Peso	A	B	D	F	G	H	J	O	P	Q	R	Accessories Accessoires Accessori				
			[mm]	[kg]	[mm]											BAK.	SOK.	TSK.A
KCM080HG+001561N3	Ø 75	87,2	647,3	407	245	204,5	176	121	562	80	16	80	16 (*)	F 2", G/F 2", F-A 2"	80/N3	K80	80	
KCM080HD+001561N3	Ø 75	87,1	647,3	407	245	204,5	176	121	562	80	16	80	16 (*)	F 2", G/F 2", F-A 2"	80/N3	K80	80	
KCM080HA+001561N3	Ø 75	84,9	647,3	407	245	204,5	176	121	562	80	16	80	16 (*)	F 2", G/F 2", F-A 2"	80/N3	K80	80	
BAK.	a	b	c	d	e	f	g	h	i	j	l	m	n	o	r	t	y	z
BAKF 2"	130	12,5	35	2"	220	102	40	320	180	18	47	320	110	156	80	ex PN10	255	477
BAKG/F 2"	130	12,5	35	2"	228	102	48	320	180	18	47	338	110	156	100	16	255	477
BAKF-A 2"	130	12,5	35	2"	220	102	40	320	180	18	47	320	110	156	80	16	255	477
SOK.	a3	f3	g3	h3	i3	k3	l3	m3	n3	o3	q3							
SOK80/N3	2	400	22	270	100	100	66	22	34	43	400							
TSK.A	a2	b2	c2	e2	f2	j2	m2	n2	v2	w2								
TSKK80A	126	164	290	4	12	390	440	164	230	200								
TSK.B	e2	f2	j2	m2	q2	r2	s2	v2	x2	y2	z2							
TSK80B	4	12	400	440	165	75	166	230	217	362	584							

(3) z = Minimum submergence depth for motor without casing with continuous duty S1 (NPSHR permitting)

y = Minimum submergence depth for motor without casing with intermittent duty S3 (NPSHR permitting)

(*) Consult the flanges page.

(3) z = Immersion minimum pour moteur sans chemise en service continu S1 (compatible avec le NPSHR)

y = Immersion minimum pour moteur sans chemise en service intermittent S3 (compatible avec le NPSHR)

(*) Voir page brides.

(3) z = Immersion minima per motore senza mantello in funzione continuo S1 compatibilmente con l'NPSHR

y = Immersion minima con motore senza mantello in funzione intermittente S3 compatibilmente con l'NPSHR

(*) Vedere pagina flange.

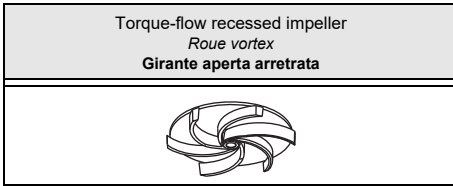

Type Type Tipo	KCW080H...+...41N3	KCW080H...+...41X3
Thermal probes Sondes thermiques Sonda termiche	Yes Oui Sì	Yes Oui Sì
Conductivity probe Sonde de conductivité Sonda di conduttività	Yes Oui Sì	Yes Oui Sì

Version cable (1)
Version câble (1)
Cavo Versione (1)

Electric pump type Electropompe type Elettropompa tipo	Power supply Alimentation Alimentazione	Auxiliary Auxiliaire Ausiliario
KCW080HP+001641N3	1x(7x1,5)x10	
KCW080HM+001641N3	1x(7x1,5)x10	
KCW080HI+002141N3	1x(7x1,5)x10	
KCW080HH+002941N3	1x(7x1,5)x10	
KCW080HE+003741N3	1x(7x1,5)x10	
KCW080HC+004641N3	1x(7x1,5)x10	
KCW080HA+005842N3	1x(10x2,5)x10	

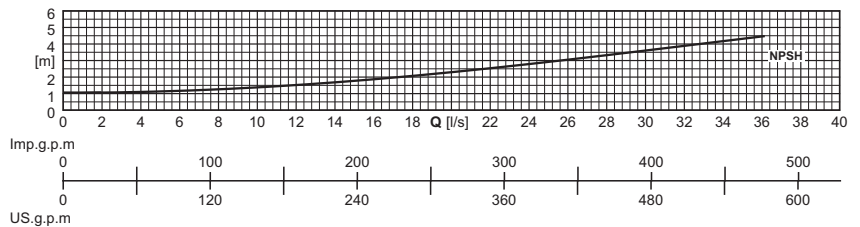
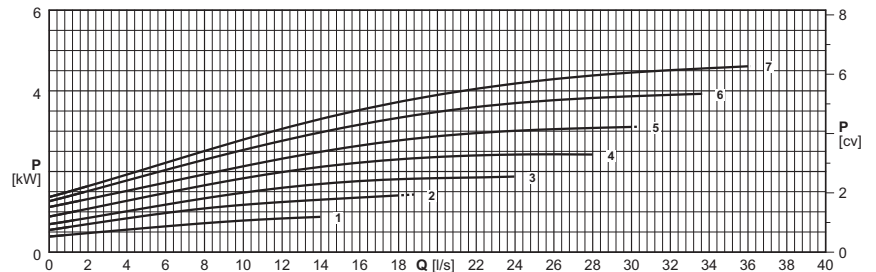
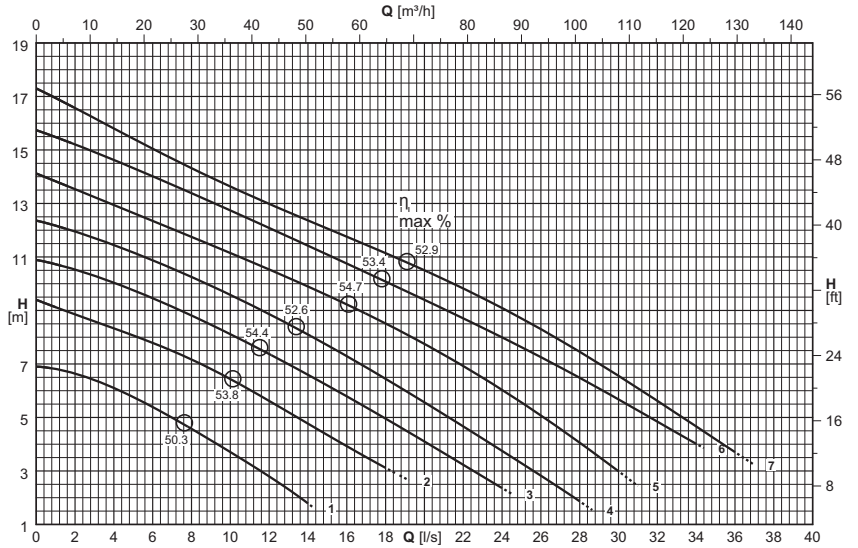

(1) = n°. of cables x (n°. of wires each cable x size [mm²]) x cable length [m] - Cable NSSHÖU-J

Cable length exceeding 10 m on request

(1) = n°. câbles x (n°. conducteurs câble x section [mm²]) x longueur câble [m] - Câble NSSHÖU-J

Sur demande longueur de câble supérieure à 10 m

(1) = n°. cavi x (n°. conduttori per cavo x sezione [mm²]) x lunghezza cavo [m] - Cavo NSSHÖU-J

Lunghezza cavo superiore a 10 m - su richiesta

Electric pump type Electropompe type Elettropompa tipo	Curve Courbe Curva	Motor power Puiss. moteur Potenza motore	Capacity Débit Portata																	
			[l/s]	0	0,8	1	2	4	6	8	10	15	20	25	30	35	36			
			P ₂	[m ³ /h]	0	2,9	3,6	7,2	14,4	21,6	28,8	36	54	72	90	108	126	129,6		
			(N°)	[kW]	Head Hauteur Prevalenza															
				[m]	6,9	6,8	6,8	6,6	6,1	5,4	4,6	3,7								
KCW080HP+001641N3	1	1,6		[m]	6,9	6,8	6,8	6,6	6,1	5,4	4,6	3,7								
KCW080HM+001641N3	2	1,6		[m]	9,4	9,2	9,1	8,9	8,3	7,8	7,2	6,4	4,3							
KCW080HI+002141N3	3	2,1		[m]	10,9	10,8	10,7	10,5	10	9,5	8,8	8,1	6,2	4,1						
KCW080HH+002941N3	4	2,9		[m]	12,4	12,2	12,2	11,9	11,4	10,9	10,2	9,6	7,7	5,6	3,3					
KCW080HE+003741N3	5	3,7		[m]	14,1	13,9	13,8	13,5	12,9	12,3	11,7	11,1	9,6	7,7	5,6	3				
KCW080HC+004641N3	6	4,6		[m]	15,7	15,5	15,5	15,2	14,6	14	13,4	12,7	11,1	9,4	7,6	5,7				
KCW080HA+005842N3	7	5,8		[m]	17,3	17	16,9	16,6	15,8	15	14,3	13,6	12,1	10,5	8,7	6,5	4,2	3,7		
NPSH _R				[m]				1,1	1,1	1,2	1,3	1,4	1,8	2,3	2,9	3,6	4,3	4,5		

P₂ = Power rated by the motor

Performance tolerance as per:
UNI/ISO 9906 Grade 3B

For motor performances specification see page "motor features"

For the accessories specification see page "Accessories"

The impellers will be trimmed to meet the duty point

P₂ = Puissance restituée par le moteur

Tolérances sur les performances selon normes:
UNI/ISO 9906 Niveau 3B

Pour caractéristiques techniques moteurs voir page "Caractéristiques des moteurs"

Pour les accessoires voir page "Accessories"

Le point de fonctionnement désiré peut être obtenu par rognage de roue

P₂ = Potenza resa dal motore

Tolleranze sulle prestazioni secondo norme:
UNI/ISO 9906 Grado 3B

Per caratteristiche motori vedere pagina "caratteristiche motori"

Per accessori vedere pagina accessori

Le giranti vengono tornite in modo da ottenere il punto di lavoro richiesto

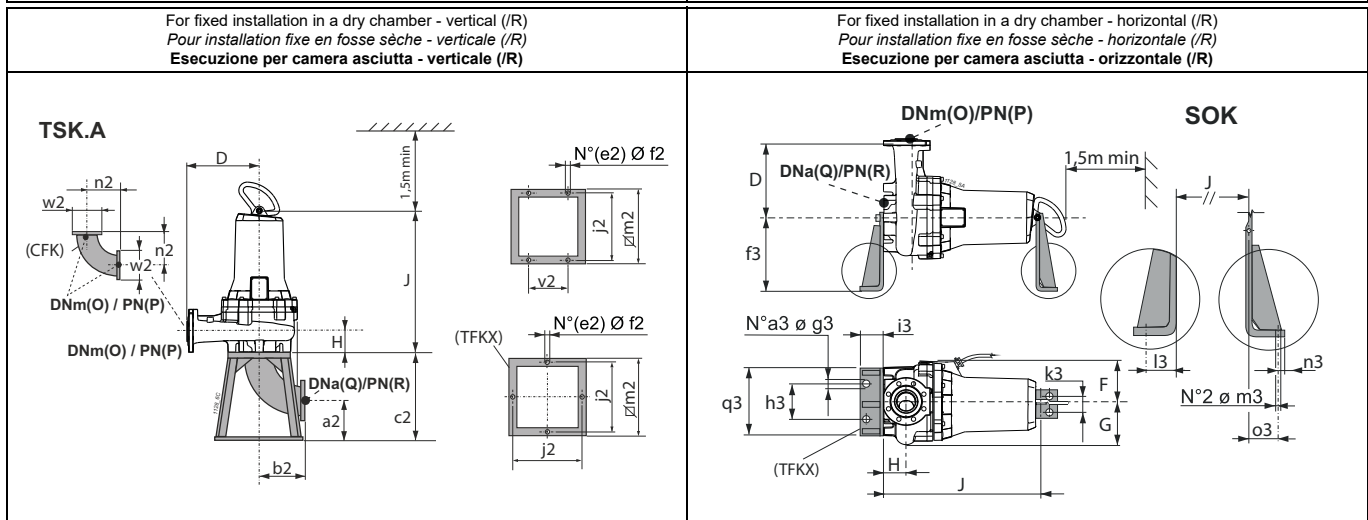
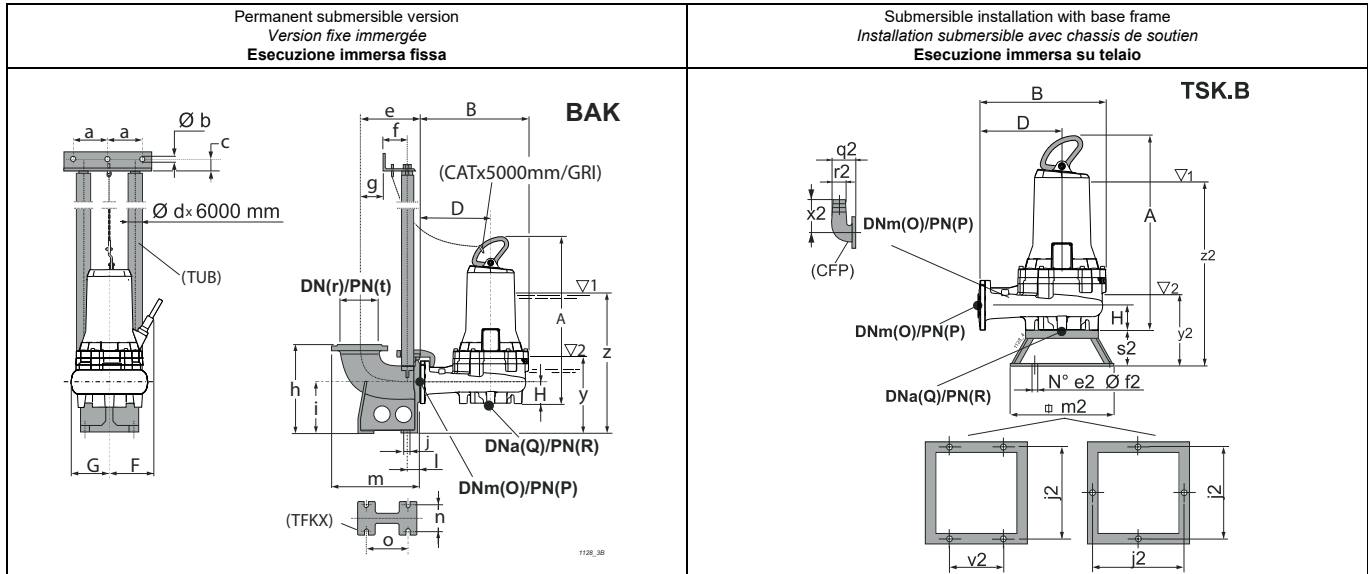

Type Type Tipo	Free passage Passage libre Passaggio Libero	Weight Poids Peso	A	B	D	F	G	H	J	O	P	Q	R	Accessories Accessoires Accessori			
			[mm]	[kg]	[mm]											BAK.	SOK.
KCW080HP+001641N3	Ø 80	87,8	638,3	392	245	204,5	146	92	553	80	16	80	16 (*)	F 2", G/F 2", F-A 2"	80/N3	K80	80
KCW080HM+001641N3	Ø 80	88,7	638,3	392	245	204,5	146	92	553	80	16	80	16 (*)	F 2", G/F 2", F-A 2"	80/N3	K80	80
KCW080HI+002141N3	Ø 80	90,2	638,3	392	245	204,5	146	92	553	80	16	80	16 (*)	F 2", G/F 2", F-A 2"	80/N3	K80	80
KCW080HH+002941N3	Ø 80	94,5	638,3	392	245	204,5	146	92	553	80	16	80	16 (*)	F 2", G/F 2", F-A 2"	80/N3	K80	80
KCW080HE+003741N3	Ø 80	109,5	707,4	392	245	221	146	92	589	80	16	80	16 (*)	F 2", G/F 2", F-A 2"	80/N3	K80	80
KCW080HC+004641N3	Ø 80	109,7	707,4	392	245	221	146	92	589	80	16	80	16 (*)	F 2", G/F 2", F-A 2"	80/N3	K80	80
KCW080HA+005842N3	Ø 80	114,7	707,4	392	245	221	146	92	589	80	16	80	16 (*)	F 2", G/F 2", F-A 2"	80/N3	K80	80

BAK.	a	b	c	d	e	f	g	h	i	j	l	m	n	o	r	t	y	z
BAKF 2"	130	12,5	35	2"	220	102	40	320	180	18	47	320	110	156	80	ex PN10	277	529
BAKG/F 2"	130	12,5	35	2"	228	102	48	320	180	18	47	338	110	156	100	16	277	529
BAKF-A 2"	130	12,5	35	2"	220	102	40	320	180	18	47	320	110	156	80	16	277	529

SOK.	a3	f3	g3	h3	i3	k3	l3	m3	n3	o3	q3
SOK80/N3	2	400	22	270	100	100	66	22	34	43	400

TSK.A	a2	b2	c2	e2	f2	j2	m2	n2	v2	w2
TSKK80A	126	164	290	4	12	390	440	164	230	200

TSK.B	e2	f2	j2	m2	q2	r2	s2	v2	x2	y2	z2
TSK80B	4	12	400	440	165	75	166	230	217	355	607

(3) z = Minimum submergence depth for motor without casing with continuous duty S1 (NPSHR permitting) (3) z = Immersion minimum pour moteur sans chemise en service continu S1 (compatible avec le NPSHR) (3) z = Immersion minima per motore senza mantello in funzione continuo S1 compatibilmente con l'NPSHR

y = Minimum submergence depth for motor without casing with intermittent duty S3 (NPSHR permitting) y = Immersion minimum pour moteur sans chemise en service intermittent S3 (compatible avec le NPSHR) y = Immersion minima con motore senza mantello in funzione intermittente S3 compatibilmente con l'NPSHR

(*) Consult the flanges page. (*) Voir page brides. (*) Vedere pagina flange.

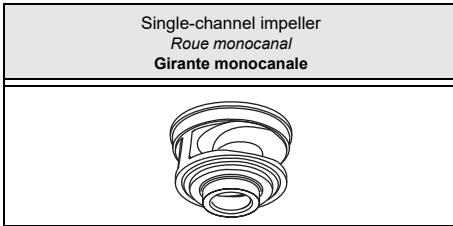

Type Type Tipo	KCM080F...41N3	KCM080F...41X3
Thermal probes Sondes thermiques Sonda termiche	Yes Oui Sì	Yes Oui Sì
Conductivity probe Sonde de conductivité Sonda di conduttività	Yes Oui Sì	Yes Oui Sì

Version cable (1)
Version câble (1)
Cavo Versione (1)

Electric pump type Electropompe type Elettropompa tipo	Power supply Alimentazione	Auxiliary Auxiliaire Ausiliario
KCM080FL+001641N3	1x(4x1,5)x10	
KCM080FG+001641N3	1x(4x1,5)x10	
KCM080FD+002141N3	1x(4x1,5)x10	
KCM080FA+002141N3	1x(4x1,5)x10	

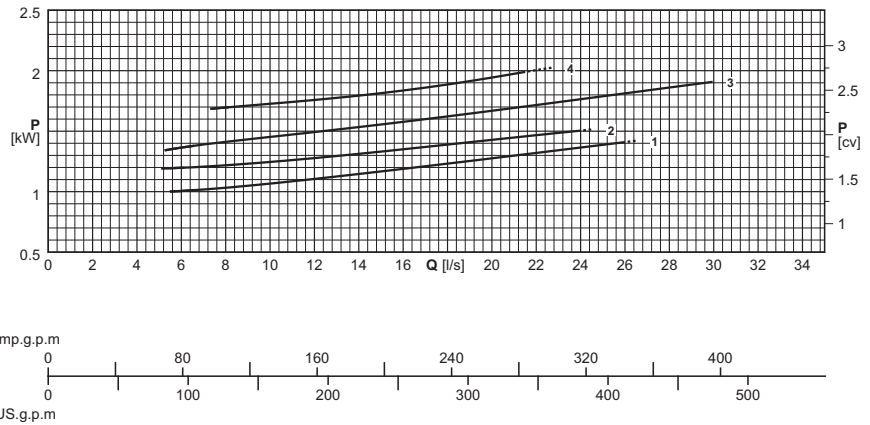
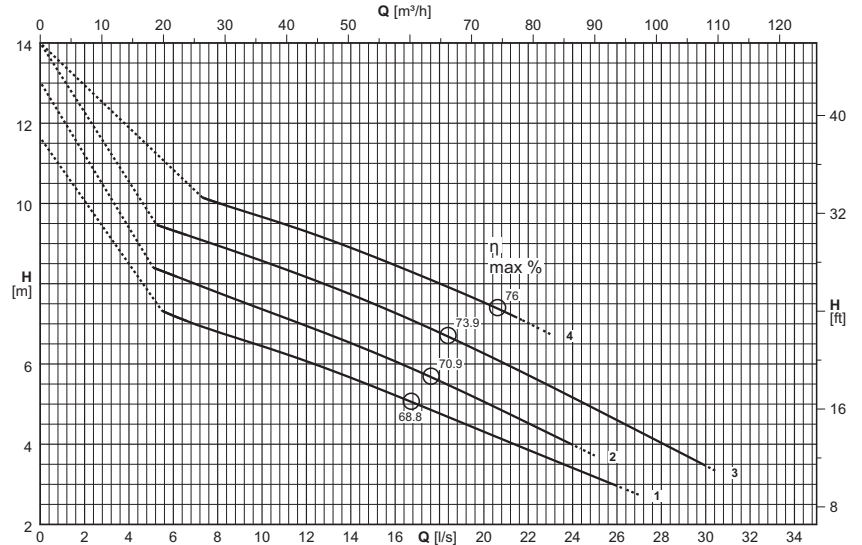

(1) = n°. of cables x (n°. of wires each cable x size [mm²]) x cable length [m] - Cable NSSHÔU-J
Cable length exceeding 10 m on request

(1) = n°. câbles x (n°. conducteurs câble x section [mm²]) x longueur câble [m] - Câble NSSHÔU-J
Sur demande longueur de câble supérieure à 10 m

(1) = n°. cavi x (n°. conduttori per cavo x sezione [mm²]) x lunghezza cavo [m] - Cavo NSSHÔU-J
Lunghezza cavo superiore a 10 m - su richiesta

Electric pump type Electropompe type Elettropompa tipo	Curve Courbe Curva	Motor power Puiss. moteur Potenza motore	Capacity Débit Portata																	
			[l/s]	0	6	7	8	9	10	12,5	15	17,5	20	22,5	25	27,5	30			
			P ₂	[m³/h]	0	21,6	25,2	28,8	32,4	36	45	54	63	72	81	90	99	108		
			(N°)	[kW]	Head Hauteur Prevalenza															
			[m]	[m]	9,6	7,2	7	6,8	6,6	6,4	6	5,4	4,9	4,3	3,7	3,2				
KCM080FL+001641N3	1	1,6	[m]	[m]	9,6	7,2	7	6,8	6,6	6,4	6	5,4	4,9	4,3	3,7	3,2				
KCM080FG+001641N3	2	1,6	[m]	[m]	11	8,2	8	7,8	7,6	7,4	6,8	6,3	5,7	5,1	4,4	3,7				
KCM080FD+002141N3	3	2,1	[m]	[m]	12,6	9,3	9,1	9	8,8	8,6	8,1	7,5	6,9	6,3	5,6	4,9	4,2	3,5		
KCM080FA+002141N3	4	2,1	[m]	[m]	13,9			10	9,8	9,7	9,2	8,7	8,1	7,5	6,9					
NPSH _R			[m]	[m]																

P₂ = Power rated by the motor
Performance tolerance as per:
UNI/ISO 9906 Grade 3B
For motor performances specification see page "motor features"
For the accessories specification see page "Accessories"

P₂ = Puissance restituée par le moteur
Tolérances sur les performances selon normes:
UNI/ISO 9906 Niveau 3B
Pour caractéristiques techniques moteurs voir page "Caractéristiques des moteurs"
Pour les accessoires voir page "Accessories"

P₂ = Potenza resa dal motore
Tolleranze sulle prestazioni secondo norme:
UNI/ISO 9906 Grado 3B
Per caratteristiche motori vedere pagina "caratteristiche motori"
Per accessori vedere pagina accessori

Permanent submersible version
Version fixe immergée
Esecuzione immersa fissa

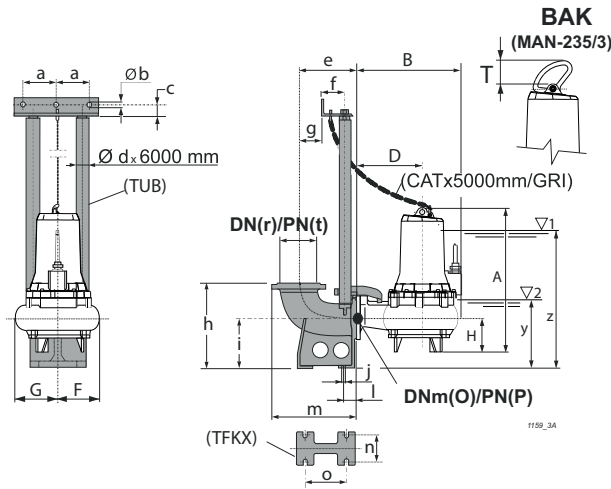

Type Type Tipo	Free passage Passage libre Passaggio Libero			Weight Poids Peso	A	B	D	F	G	H	O	P	T	Accessories Accessoires Accessori				
	[mm]	[mm]	[kg]															
KCM080FL+001641N3	Ø 75		74,9	622,6	393	235	144	173	180	80	16	65,3	F 2", G/F 2", F-A 2"					
KCM080FG+001641N3	Ø 75		74,9	622,6	393	235	144	173	180	80	16	65,3	F 2", G/F 2", F-A 2"					
KCM080FD+002141N3	Ø 75		79,9	622,6	393	235	144	173	180	80	16	65,3	F 2", G/F 2", F-A 2"					
KCM080FA+002141N3	Ø 75		79,9	622,6	393	235	144	173	180	80	16	65,3	F 2", G/F 2", F-A 2"					
BAK.	a	b	c	d	e	f	g	h	i	j	l	m	n	o	r	t	y	z
BAKF 2"	130	12,5	35	2"	220	102	40	320	180	18	47	320	110	156	80	ex PN10	287	452
BAKG/F 2"	130	12,5	35	2"	228	102	48	320	180	18	47	338	110	156	100	16	287	452
BAKF-A 2"	130	12,5	35	2"	220	102	40	320	180	18	47	320	110	156	80	16	287	452

(3) z = Minimum submergence depth for motor without casing with continuous duty S1 (NPSHR permitting)

y = Minimum submergence depth for motor without casing with intermittent duty S3 (NPSHR permitting)

(3) z = Immersion minimum pour moteur sans chemise en service continu S1 (compatible avec le NPSHR)

y = Immersion minimum pour moteur sans chemise en service intermittent S3 (compatible avec le NPSHR)

(3) z = Immersion minima per motore senza mantello in funzione continuo S1 compatibilmente con l'NPSHR

y = Immersion minima con motore senza mantello in funzione intermittente S3 compatibilmente con l'NPSHR

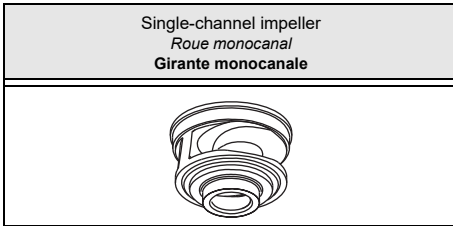

Type Type Tipo	KCM080H...41N3	KCM080H...41X3
Thermal probes Sondes thermiques Sonda termiche	Yes Oui Sì	Yes Oui Sì
Conductivity probe Sonde de conductivité Sonda di conduttività	Yes Oui Sì	Yes Oui Sì

Version cable (1)
Version câble (1)
Cavo Versione (1)

Electric pump type Electropompe type Elettropompa tipo	Power supply Alimentazione	Auxiliary Auxiliaire Ausiliario
KCM080HG+001641N3	1x(7x1,5)x10	
KCM080HD+002141N3	1x(7x1,5)x10	
KCM080HL+002941N3	1x(7x1,5)x10	
KCM080HA+002941N3	1x(7x1,5)x10	
KCM080HG+003741N3	1x(7x1,5)x10	
KCM080HD+004641N3	1x(7x1,5)x10	
KCM080HA+005842N3	1x(10x2,5)x10	

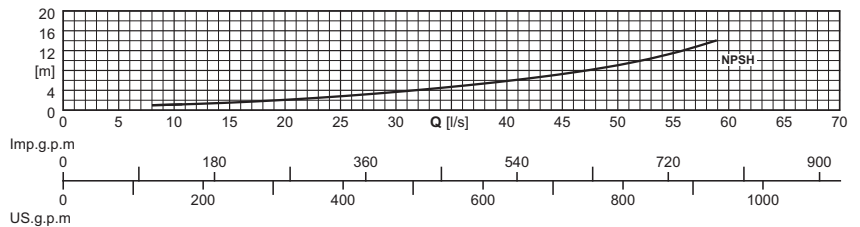
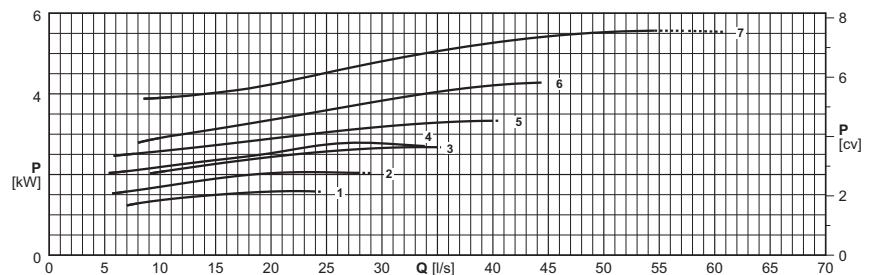
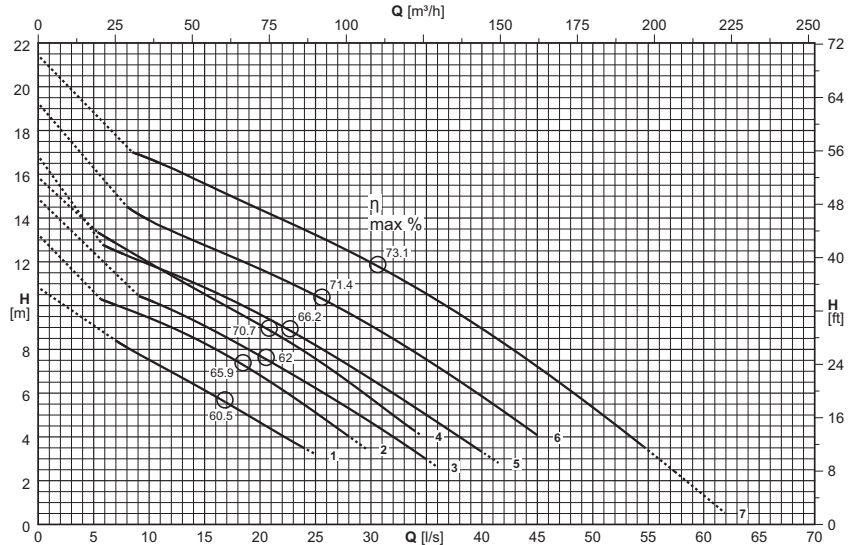

(1) = n°. of cables x (n°. of wires each cable x size [mm²]) x cable length [m] - Câble NSSHÖU-J

Cable length exceeding 10 m on request

(1) = n°. câbles x (n°. conducteurs câble x section [mm²]) x longueur câble [m] - Câble NSSHÖU-J

Sur demande longueur de câble supérieure à 10 m

(1) = n°. cavi x (n°. conduttori per cavo x sezione [mm²]) x lunghezza cavo [m] - Cavo NSSHÖU-J

Lunghezza cavo superiore a 10 m - su richiesta

Electric pump type Electropompe type Elettropompa tipo	Curve Courbe Curva	Motor power Puiss. moteur Potenza motore	Capacity Débit Portata																	
			[l/s]	0	6	8	10	15	20	25	30	35	40	45	50	55	60	61		
			P ₂	[m ³ /h]	0	21,6	28,8	36	54	72	90	108	126	144	162	180	198	216	219,6	
			(N°)	[kW]	Head Hauteur Prevalenza															
			[m]	[m]	10,8	13,2	14,9	15,9	16,8	18,3	19,3	21,4	21,4	21,4	21,4	21,4	21,4	21,4	21,4	21,4
KCM080HG+001641N3	1	1,6																		
KCM080HD+002141N3	2	2,1																		
KCM080HL+002941N3	3	2,9																		
KCM080HA+002941N3	4	2,9																		
KCM080HG+003741N3	5	3,7																		
KCM080HD+004641N3	6	4,6																		
KCM080HA+005842N3	7	5,8																		
NPSH _R						1	1,1	1,5	2,1	2,8	3,7	4,7	5,9	7,3	9,1	11,5	15			

P₂ = Power rated by the motor

Performance tolerance as per:
UNI/ISO 9906 Grade 3B

For motor performances specification see page "motor features"

For the accessories specification see page "Accessories"

P₂ = Puissance restituée par le moteur

Tolérances sur les performances selon normes:
UNI/ISO 9906 Niveau 3B

Pour caractéristiques techniques moteurs voir page "Caractéristiques des moteurs"

Pour les accessoires voir page "Accessories"

P₂ = Potenza resa dal motore

Tolleranze sulle prestazioni secondo norme:
UNI/ISO 9906 Grado 3B

Per caratteristiche motori vedere pagina "caratteristiche motori"

Per accessori vedere pagina accessori

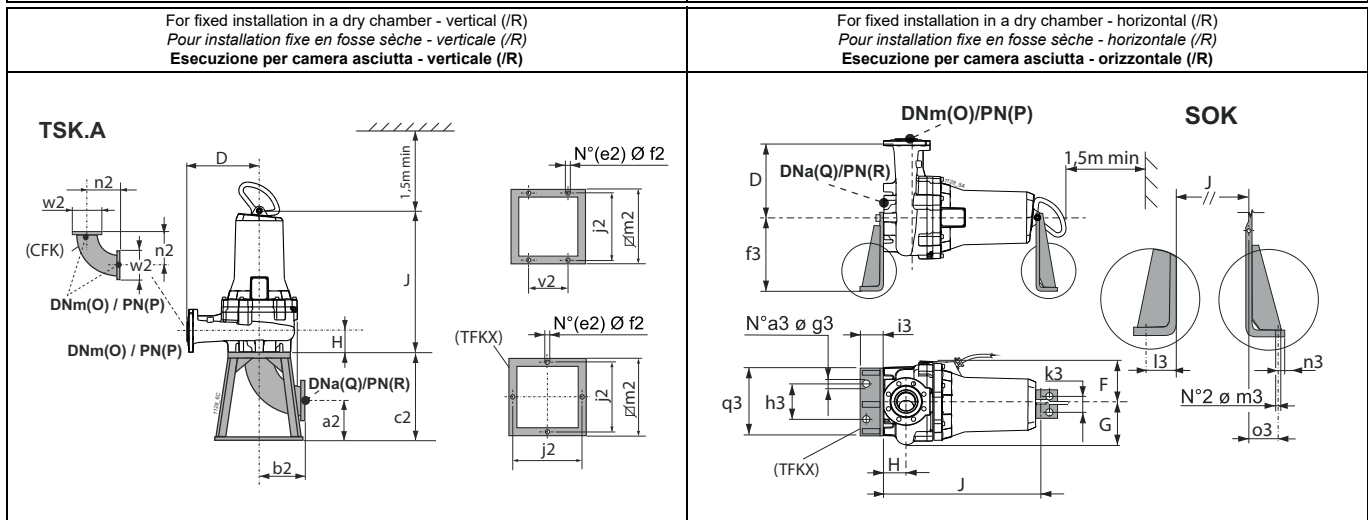
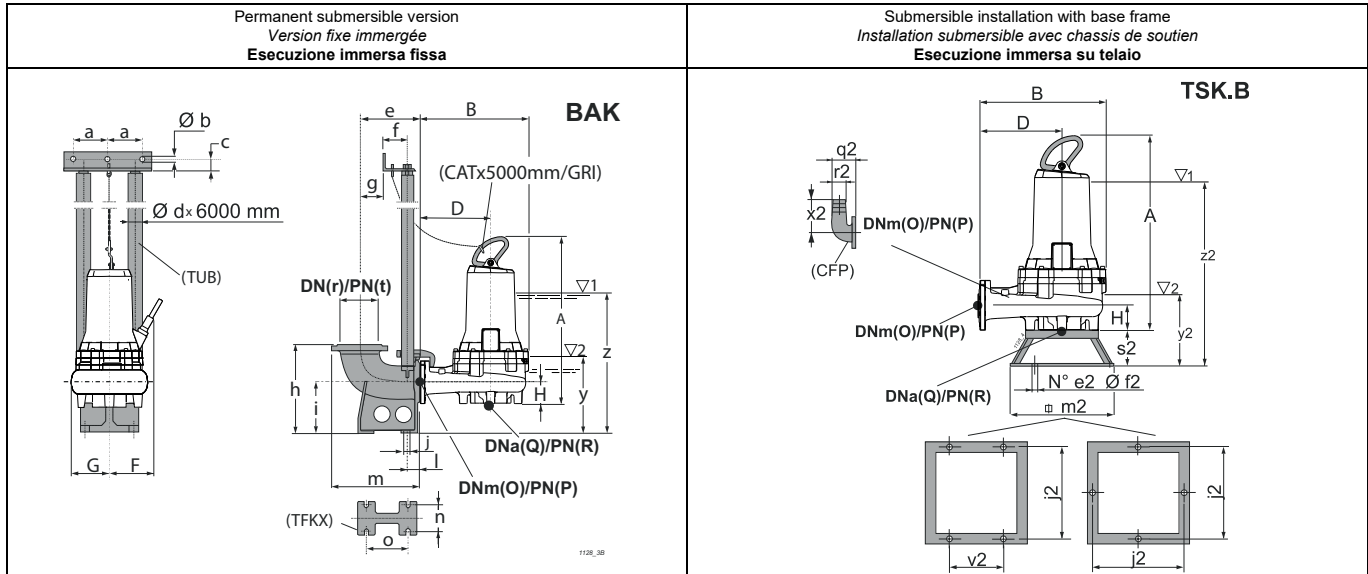

Type Type Tipo	Free passage Passage libre Passaggio Libero	Weight Poids Peso	A	B	D	F	G	H	J	O	P	Q	R	Accessories Accessoires Accessori			
														[mm]	[kg]	[mm]	
KCM080HG+001641N3	Ø 75	91,3	647,3	407	245	204,5	176	121	562	80	16	80	16 (*)	F 2", G/F 2", F-A 2"	80/N3	K80	80
KCM080HD+002141N3	Ø 75	95,6	650,3	435	255	204,5	176	118	565	80	16	80	16 (*)	F 2", G/F 2", F-A 2"	80/N3	K80	80
KCM080HA+002941N3	Ø 80	103,2	647,3	407	245	204,5	176	120,5	562	80	16	100	16	F 2", G/F 2", F-A 2"	100/N3	100	100
KCM080HA+002941N3	Ø 75	93,4	647,3	407	245	204,5	176	121	562	80	16	80	16 (*)	F 2", G/F 2", F-A 2"	80/N3	K80	80
KCM080HG+003741N3	Ø 80	117,6	716,4	407	245	221	176	120,5	598	80	16	100	16	F 2", G/F 2", F-A 2"	100/N3	100	100
KCM080HD+004641N3	Ø 80	117,5	716,4	407	245	221	176	120,5	598	80	16	100	16	F 2", G/F 2", F-A 2"	100/N3	100	100
KCM080HA+005842N3	Ø 80	126,6	716,4	407	245	221	176	120,5	598	80	16	100	16	F 2", G/F 2", F-A 2"	100/N3	100	100

BAK.	a	b	c	d	e	f	g	h	i	j	l	m	n	o	r	t	y	z
BAKF 2"	130	12,5	35	2"	220	102	40	320	180	18	47	320	110	156	80	ex PN10	260	550
BAKG/F 2"	130	12,5	35	2"	228	102	48	320	180	18	47	338	110	156	100	16	260	550
BAKF-A 2"	130	12,5	35	2"	220	102	40	320	180	18	47	320	110	156	80	16	260	550

SOK.	a3	f3	g3	h3	i3	k3	l3	m3	n3	o3	q3
SOK80/N3	2	400	22	270	100	100	66	22	34	43	400
SOK100/N3	2	400	22	320	100	100	66	22	34	43	470

TSK.A	a2	b2	c2	e2	f2	j2	m2	n2	v2	w2
TSKK80A	126	164	290	4	12	390	440	164	230	200
TSK100A	135	204	340	4	22	600	650	164	-	200

TSK.B	e2	f2	j2	m2	q2	r2	s2	v2	x2	y2	z2
TSK80B	4	12	400	440	165	75	166	230	217	362	584
TSK100B	4	14	600	650	165	75	180	350	217	380,5	670,5

(3) z = Minimum submergence depth for motor without casing with continuous duty S1 (NPSHR permitting)

y = Minimum submergence depth for motor without casing with intermittent duty S3 (NPSHR permitting)

(*) Consult the flanges page.

(3) z = Immersion minimum pour moteur sans chemise en service continu S1 (compatible avec le NPSHR)

y = Immersion minimum pour moteur sans chemise en service intermittent S3 (compatible avec le NPSHR)

(*) Voir page brides.

(3) z = Immersion minima per motore senza mantello in funzione continuo S1 compatibilmente con l'NPSHR

y = Immersion minima con motore senza mantello in funzione intermittente S3 compatibilmente con l'NPSHR

(*) Vedere pagina flange.

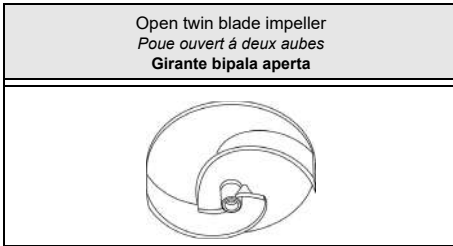

Type Type Tipo	KCA080H...41N3	KCA080H...41X3
Thermal probes Sondes thermiques Sonde termiche	Yes Oui Sì	Yes Oui Sì
Conductivity probe Sonde de conductivité Sonda di conduttività	Yes Oui Sì	Yes Oui Sì

Version cable (1) Version câble (1) Cavo Versione (1)		
Electric pump type Electropompe type Elettropompa tipo	Power supply Alimentation Alimentazione	Auxiliary Auxiliaire Ausiliario
KCA080HL+001641N3	1x(7x1,5)x10	
KCA080HG+001641N3	1x(7x1,5)x10	
KCA080HD+002141N3	1x(7x1,5)x10	
KCA080HA+002941N3	1x(7x1,5)x10	

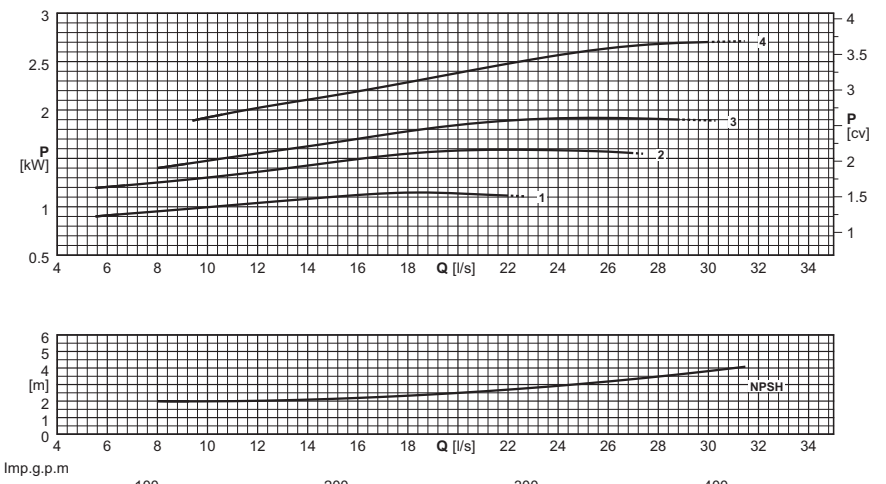
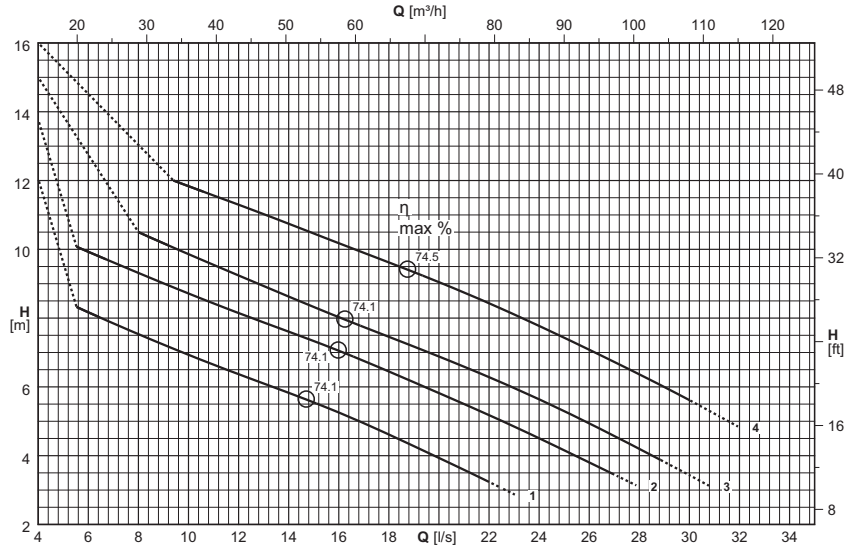

(1) = n°. of cables x (n°. of wires each cable x size [mm²]) x cable length [m] - Câble NSSHÖU-J
Cable length exceeding 10 m on request

(1) = n°. câbles x (n°. conducteurs câble x section [mm²]) x longueur câble [m] - Câble NSSHÖU-J
Sur demande longueur de câble supérieure à 10 m

(1) = n°. cavi x (n°. conduttori per cavo x sezione [mm²]) x lunghezza cavo [m] - Cavo NSSHÖU-J
Lunghezza cavo superiore a 10 m - su richiesta

Electric pump type Electropompe type Elettropompa tipo	Curve Courbe Curva	Motor power Puiss. moteur Potenza motore	Capacity Débit Portata																	
			[l/s]	0	6	7	8	9	10	12,5	15	17,5	20	22,5	25	27,5	30	31		
			P ₂	[m ³ /h]	0	21,6	25,2	28,8	32,4	36	45	54	63	72	81	90	99	108	111,6	
			(N°)	[kW]	Head Hauteur Prevalenza															
			[m]	[m]	10,1	8,2	7,8	7,5	7,2	6,9	6,2	5,5	4,8	3,9	3,1					
KCA080HL+001641N3	1	1,6	[m]	[m]	11,8	9,9	9,6	9,3	9	8,7	8	7,3	6,6	5,8	5	4,2	3,3			
KCA080HG+001641N3	2	1,6	[m]	[m]	13			10,5	10,2	9,9	9,1	8,3	7,6	6,9	6,1	5,3	4,4	3,4		
KCA080HD+002141N3	3	2,1	[m]	[m]	15					11,8	11,2	10,5	9,8	9	8,3	7,4	6,5	5,6	5,2	
KCA080HA+002941N3	4	2,9	[m]	[m]																
NPSH _R			[m]	[m]				2	2	2	2,1	2,2	2,3	2,5	2,7	3	3,4	3,8	4	

P₂ = Power rated by the motor
Performance tolerance as per:
UNI/ISO 9906 Grade 3B

For motor performances specification see page "motor features"

For the accessories specification see page "Accessories"
The impellers will be trimmed to meet the duty point

P₂ = Puissance restituée par le moteur
Tolérances sur les performances selon normes:
UNI/ISO 9906 Niveau 3B
Pour caractéristiques techniques moteurs voir page "Caractéristiques des moteurs"

For the accessories voir page "Accessories"
Le point de fonctionnement désiré peut être obtenu par rognage de roue

P₂ = Potenza resa dal motore
Tolleranze sulle prestazioni secondo norme:
UNI/ISO 9906 Grado 3B

Per caratteristiche motori vedere pagina "caratteristiche motori"

Per accessori vedere pagina accessori
Le giranti vengono tornite in modo da ottenere il punto di lavoro richiesto

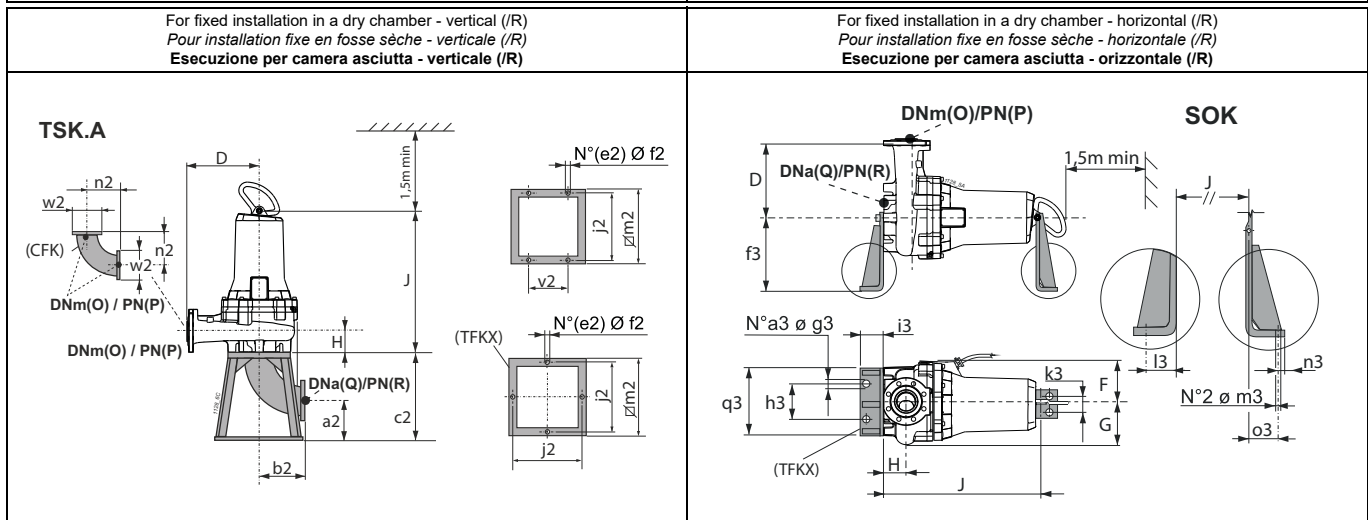
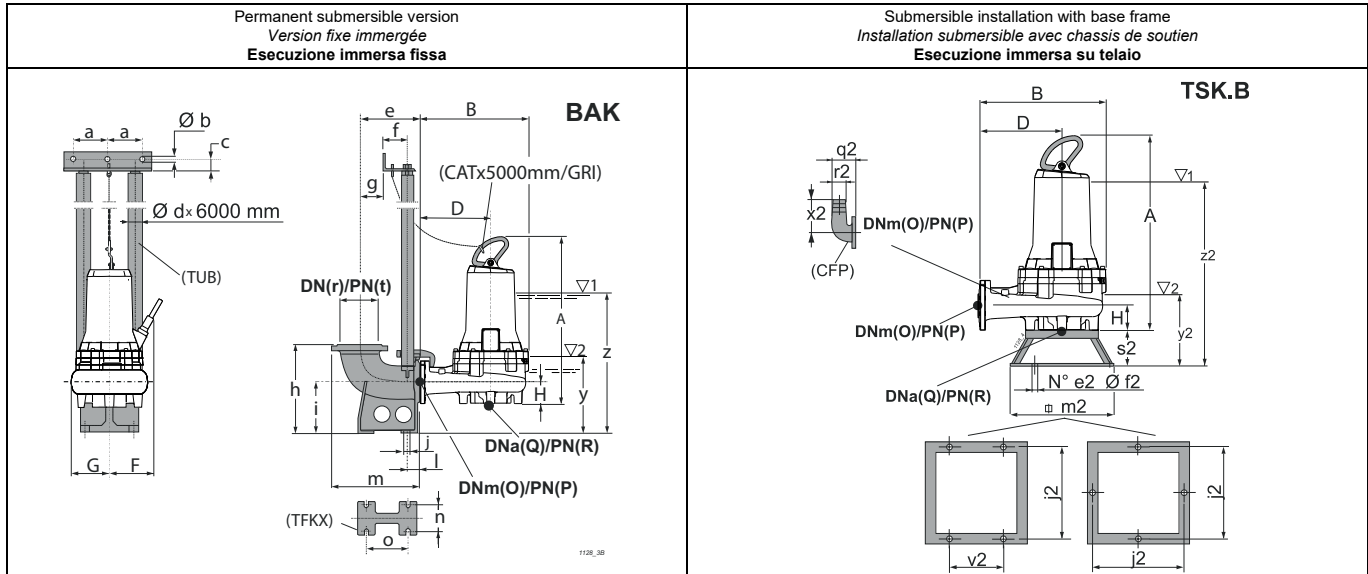

Type Type Tipo	Free passage Passage libre Passaggio Libero	Weight Poids Peso	A	B	D	F	G	H	J	O	P	Q	R	Accessories Accessoires Accessori			
			[mm]	[kg]	[mm]											BAK.	SOK.
KCA080HL+001641N3	---	78,3	615,3	416	245	204,5	190,5	98	530	80	16	80	16 (*)	F 2", G/F 2", F-A 2"	80/N3	K80	80
KCA080HG+001641N3	---	78,6	615,3	416	245	204,5	190,5	98	530	80	16	80	16 (*)	F 2", G/F 2", F-A 2"	80/N3	K80	80
KCA080HD+002141N3	---	80,1	615,3	416	245	204,5	190,5	98	530	80	16	80	16 (*)	F 2", G/F 2", F-A 2"	80/N3	K80	80
KCA080HA+002941N3	---	99,8	615,3	416	245	204,5	190,5	98	530	80	16	80	16 (*)	F 2", G/F 2", F-A 2"	80/N3	K80	80

BAK.	a	b	c	d	e	f	g	h	i	j	l	m	n	o	r	t	y	z
BAKF 2"	130	12,5	35	2"	220	102	40	320	180	18	47	320	110	156	80	ex PN10	246	468
BAKG/F 2"	130	12,5	35	2"	228	102	48	320	180	18	47	338	110	156	100	16	246	468
BAKF-A 2"	130	12,5	35	2"	220	102	40	320	180	18	47	320	110	156	80	16	246	468
SOK.	a3	f3	g3	h3	i3	k3	l3	m3	n3	o3	q3							
SOK80/N3	2	400	22	270	100	100	66	22	34	43	400							
TSK.A	a2	b2	c2	e2	f2	j2	m2	n2	v2	w2								
TSKK80A	126	164	290	4	12	390	440	164	230	200								
TSK.B	e2	f2	j2	m2	q2	r2	s2	v2	x2	y2	z2							
TSKB0B	4	12	400	440	165	75	166	230	217	330	552							

(3) z = Minimum submergence depth for motor without casing with continuous duty S1 (NPSHR permitting) (3) z = Immersion minimum pour moteur sans chemise en service continu S1 (compatible avec le NPSHR) (3) z = Immersion minima per motore senza mantello in funzione continuo S1 compatibilmente con l'NPSHR

y = Minimum submergence depth for motor without casing with intermittent duty S3 (NPSHR permitting) y = Immersion minimum pour moteur sans chemise en service intermittent S3 (compatible avec le NPSHR) y = Immersion minima con motore senza mantello in funzione intermittente S3 compatibilmente con l'NPSHR

(*) Consult the flanges page. (*) Voir page brides. (*) Vedere pagina flange.

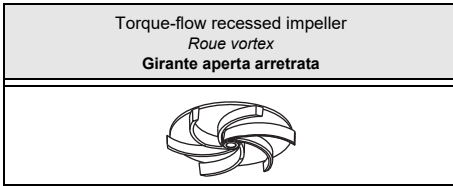

Type Type Tipo	KCW080H...+...21N3	KCW080H...+...21X3
Thermal probes Sondes thermiques Sonda termiche	Yes Oui Sì	Yes Oui Sì
Conductivity probe Sonde de conductivité Sonda di conduttività	Yes Oui Sì	Yes Oui Sì

Version cable (1)
Version câble (1)
Cavo Versione (1)

Electric pump type Electropompe type Elettropompa tipo	Power supply Alimentation Alimentazione	Auxiliary Auxiliaire Ausiliario
KCW080HZ+004821N3	1x(7x1,5)x10	
KCW080HX+004821N3	1x(7x1,5)x10	
KCW080HW+004821N3	1x(7x1,5)x10	
KCW080HV+004821N3	1x(7x1,5)x10	
KCW080HW+006522N3	1x(10x2,5)x10	
KCW080HT+006522N3	1x(10x2,5)x10	
KCW080HR+006522N3	1x(10x2,5)x10	
KCW080HQ+006522N3	1x(10x2,5)x10	
KCW080HP+006522N3	1x(10x2,5)x10	
KCW080HN+006522N3	1x(10x2,5)x10	

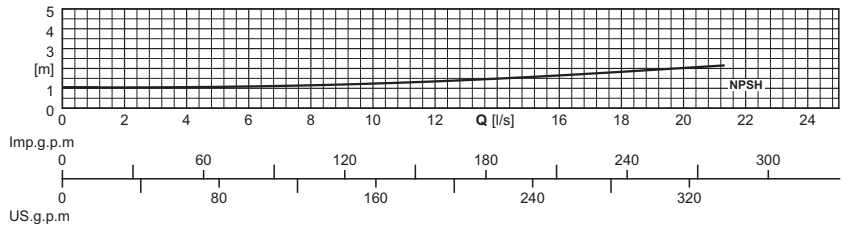
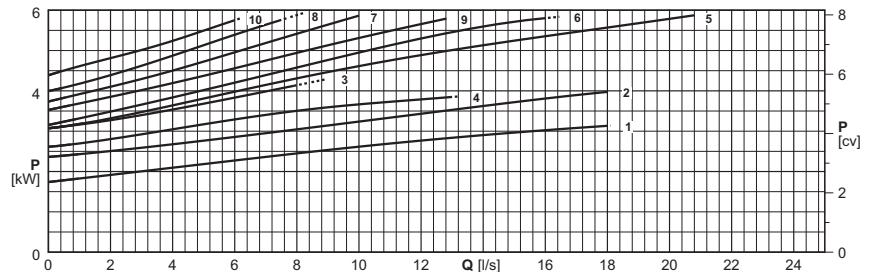
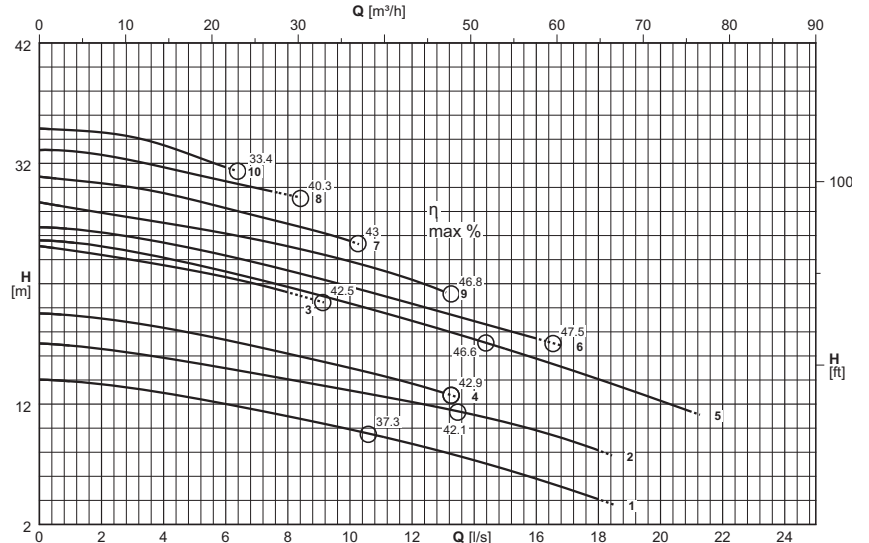

(1) = n°. of cables x (n°. of wires each cable x size [mm²]) x cable length [m] - Câble NSSHOU-J

Cable length exceeding 10 m on request

(1) = n°. câbles x (n°. conducteurs câble x section [mm²]) x longueur câble [m] - Câble NSSHOU-J

Sur demande longueur de câble supérieure à 10 m

(1) = n°. cavi x (n°. conduttori per cavo x sezione [mm²]) x lunghezza cavo [m] - Cavo NSSHOU-J

Lunghezza cavo superiore a 10 m - su richiesta

Electric pump type Electropompe type Elettropompa tipo	Curve Courbe Curva	Motor power Puiss. moteur Potenza motore	Capacity Débit Portata																			
			[l/s]	0	0,4	0,6	0,8	1	2	3	4	5	6	7	8	9	10	15	20	21		
	(N°)	[kW]	P ₂	[m ³ /h]	0	1,4	2,2	2,9	3,6	7,2	10,8	14,4	18	21,6	25,2	28,8	32,4	36	54	72	75,6	
				Head Hauteur Prevalenza																		
			[m]	14	14	13,9	13,9	13,9	13,6	13,3	12,9	12,5	12	11,5	11	10,5	9,9	6,6				
KCW080HZ+004821N3	1	4,8	[m]	14	14	13,9	13,9	13,9	13,6	13,3	12,9	12,5	12	11,5	11	10,5	9,9	6,6				
KCW080HX+004821N3	2	4,8	[m]	17	17	16,9	16,9	16,9	16,6	16,2	15,8	15,4	15	14,5	14,1	13,6	13,1	10,5				
KCW080HW+004821N3	3	4,8	[m]	25,1	25	24,9	24,8	24,8	24,4	24	23,5	23,1	22,5	22	21,3	20,6						
KCW080HV+004821N3	4	4,8	[m]	19,5	19,5	19,4	19,4	19,4	19,1	18,8	18,3	17,9	17,3	16,8	16,2	15,6	15					
KCW080HW+006522N3	5	6,5	[m]	25,6	25,5	25,5	25,5	25,4	25,1	24,7	24,2	23,6	23	22,4	21,7	21,1	20,4	16,6	12,3	11,4		
KCW080HT+006522N3	6	6,5	[m]	26,7	26,6	26,6	26,6	26,5	26,2	25,9	25,4	24,9	24,3	23,7	23,1	22,4	21,7	18,2				
KCW080HR+006522N3	7	6,5	[m]	30,9	30,8	30,7	30,7	30,6	30,3	30	29,5	28,9	28,3	27,6	27	26,3	25,5					
KCW080HQ+006522N3	8	6,5	[m]	33,1	33,1	33,1	33,1	33	32,7	32,2	31,7	31,1	30,5	29,9	29,4							
KCW080HP+006522N3	9	6,5	[m]	28,8	28,6	28,5	28,4	28,3	27,9	27,5	27,1	26,6	26,2	25,7	25,1	24,5	23,9					
KCW080HN+006522N3	10	6,5	[m]	34,9	34,8	34,8	34,8	34,8	34,6	34,2	33,5	32,6	31,7									
NPSH _R			[m]																			

P₂ = Power rated by the motor

Performance tolerance as per:
UNI/ISO 9906 Grade 3B

For motor performances specification see page "motor features"

For the accessories specification see page "Accessories"

The impellers will be trimmed to meet the duty point

P₂ = Puissance restituée par le moteur

Tolérances sur les performances selon normes:
UNI/ISO 9906 Niveau 3B

Pour caractéristiques techniques moteurs voir page "Caractéristiques des moteurs"

Pour les accessoires voir page "Accessories"

Le point de fonctionnement désiré peut être obtenu par rognage de roue

P₂ = Potenza resa dal motore

Tolleranze sulle prestazioni secondo norme:
UNI/ISO 9906 Grado 3B

Per caratteristiche motori vedere pagina "caratteristiche motori"

Per accessori vedere pagina accessori

Le giranti vengono tornite in modo da ottenere il punto di lavoro richiesto

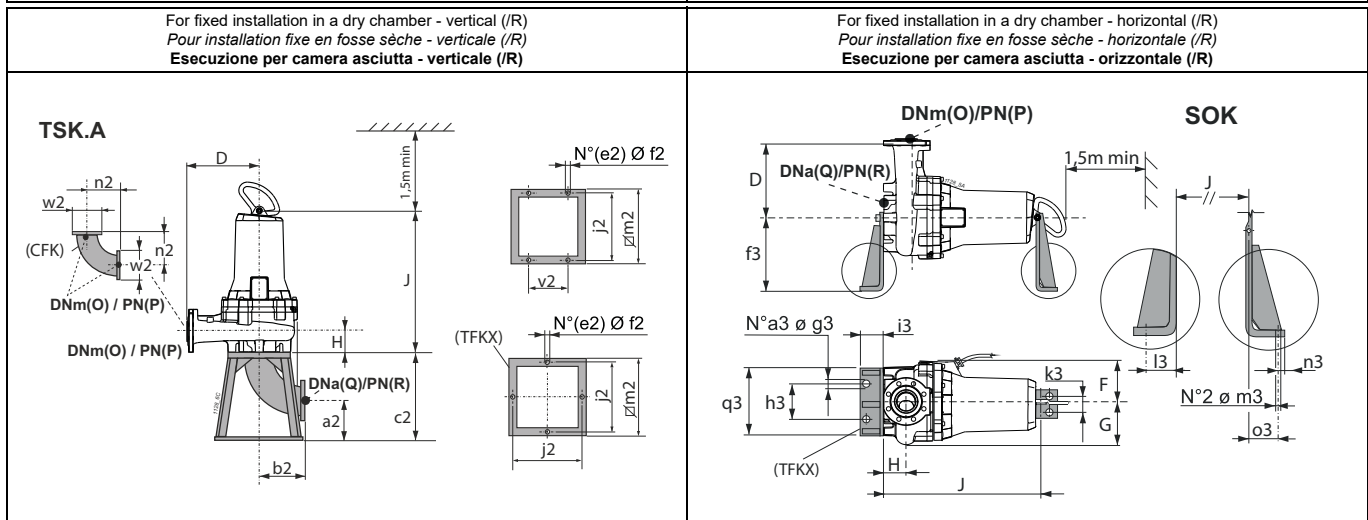
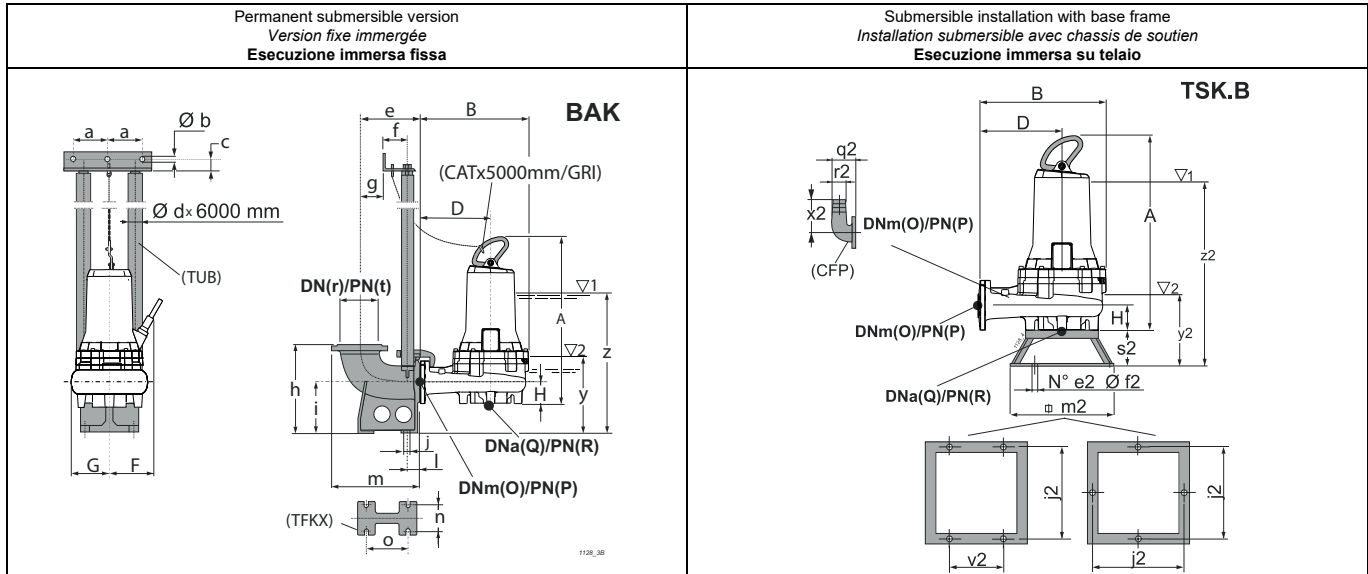

Type Type Tipo	Free passage Passage libre Passaggio Libero	Weight Poids Peso	[mm]											Accessories Accessoires Accessori			
			A	B	D	F	G	H	J	O	P	Q	R	BAK.	SOK.	TSK.A	TSK.B
KCW080HZ+004821N3	Ø 80	92,5	638,3	392	245	204,5	146	92	553	80	16	80	16 (*)	F 2", G/F 2", F-A 2"	80/N3	K80	80
KCW080HX+004821N3	Ø 80	92,7	638,3	392	245	204,5	146	92	553	80	16	80	16 (*)	F 2", G/F 2", F-A 2"	80/N3	K80	80
KCW080HW+004821N3	Ø 80	92,4	638,3	392	245	204,5	146	92	553	80	16	80	16 (*)	F 2", G/F 2", F-A 2"	80/N3	K80	80
KCW080HV+004821N3	Ø 80	92,8	638,3	392	245	204,5	146	92	553	80	16	80	16 (*)	F 2", G/F 2", F-A 2"	80/N3	K80	80
KCW080HW+006522N3	Ø 80	112,4	707,4	392	245	221	146	92	589	80	16	80	16 (*)	F 2", G/F 2", F-A 2"	80/N3	K80	80
KCW080HT+006522N3	Ø 80	112,6	707,4	392	245	221	146	92	589	80	16	80	16 (*)	F 2", G/F 2", F-A 2"	80/N3	K80	80
KCW080HR+006522N3	Ø 80	112,6	707,4	392	245	221	146	92	589	80	16	80	16 (*)	F 2", G/F 2", F-A 2"	80/N3	K80	80
KCW080HQ+006522N3	Ø 80	113	707,4	392	245	221	146	92	589	80	16	80	16 (*)	F 2", G/F 2", F-A 2"	80/N3	K80	80
KCW080HP+006522N3	Ø 80	112,4	707,4	392	245	221	146	92	589	80	16	80	16 (*)	F 2", G/F 2", F-A 2"	80/N3	K80	80
KCW080HN+006522N3	Ø 80	112,8	707,4	392	245	221	146	92	589	80	16	80	16 (*)	F 2", G/F 2", F-A 2"	80/N3	K80	80

BAK.	a	b	c	d	e	f	g	h	i	j	l	m	n	o	r	t	y	z
BAKF 2"	130	12,5	35	2"	220	102	40	320	180	18	47	320	110	156	80	ex PN10	277	529
BAKG/F 2"	130	12,5	35	2"	228	102	48	320	180	18	47	338	110	156	100	16	277	529
BAKF-A 2"	130	12,5	35	2"	220	102	40	320	180	18	47	320	110	156	80	16	277	529
SOK.	a3	f3	g3	h3	i3	k3	l3	m3	n3	o3	q3							
SOK80/N3	2	400	22	270	100	100	66	22	34	43	400							
TSK.A	a2	b2	c2	e2	f2	j2	m2	n2	v2	w2								
TSKK80A	126	164	290	4	12	390	440	164	230	200								
TSK.B	e2	f2	j2	m2	q2	r2	s2	v2	x2	y2	z2							
TSK80B	4	12	400	440	165	75	166	230	217	355	607							

(3) z = Minimum submergence depth for motor without casing with continuous duty S1 (NPSHR permitting)

y = Minimum submergence depth for motor without casing with intermittent duty S3 (NPSHR permitting)

(*) Consult the flanges page.

(3) z = Immersion minimum pour moteur sans chemise en service continu S1 (compatible avec le NPSHR)

y = Immersion minimum pour moteur sans chemise en service intermittent S3 (compatible avec le NPSHR)

(*) Voir page brides.

(3) z = Immersion minima per motore senza mantello in funzione continuo S1 compatibilmente con l'NPSHR

y = Immersione minima con motore senza mantello in funzione intermittente S3 compatibilmente con l'NPSHR

(*) Vedere pagina flange.

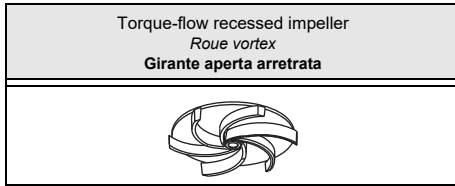

Type Type Tipo	KCW080H...+...21N3	KCW080H...+...21X3
Thermal probes Sondes termiques Sonda termiche	Yes Oui Sì	Yes Oui Sì
Conductivity probe Sonde de conductivité Sonda di conduttività	Yes Oui Sì	Yes Oui Sì

Version cable (1) <i>Version câble (1)</i> Cavo Versione (1)		
Electric pump type <i>Electropompe type</i> Elettropompa tipo	Power supply <i>Alimentation</i> Alimentazione	Auxiliary <i>Auxiliaire</i> Ausiliario
KCW080HW+009022N3	1x(10x2,5)x10	
KCW080HT+009022N3	1x(10x2,5)x10	
KCW080HR+009022N3	1x(10x2,5)x10	
KCW080HQ+009022N3	1x(10x2,5)x10	
KCW080HP+009022N3	1x(10x2,5)x10	
KCW080HN+009022N3	1x(10x2,5)x10	

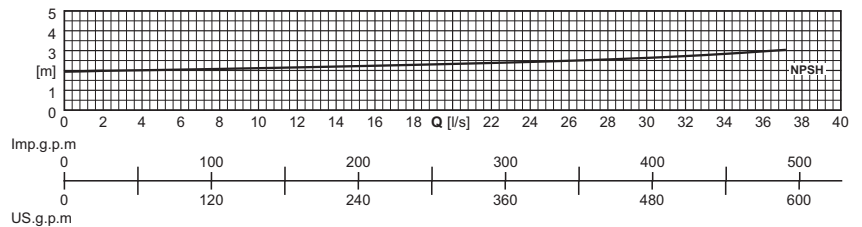
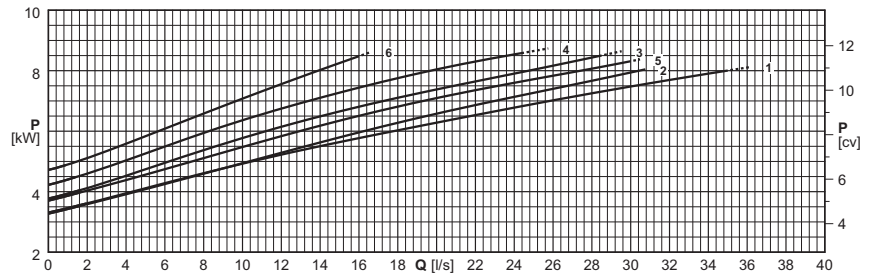
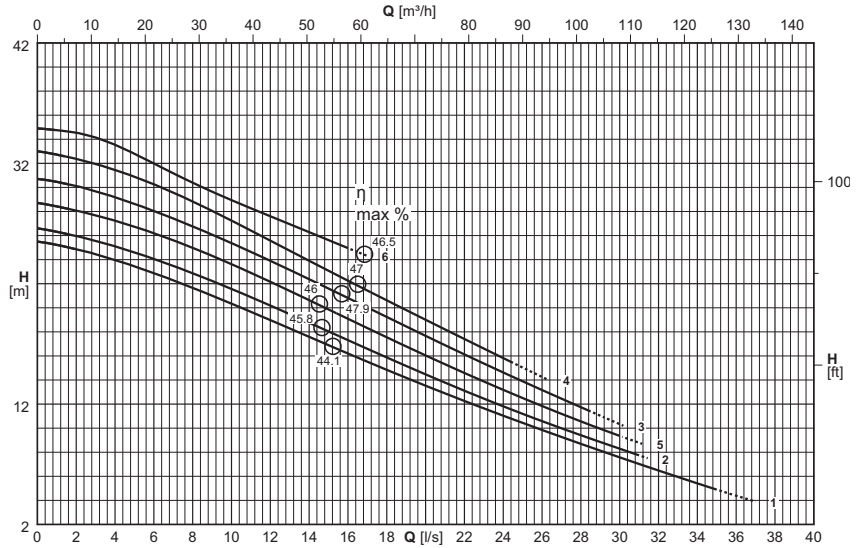

(1) = n°. of cables x (n°. of wires each cable x size [mm²]) x cable length [m] - Cable NSSHÖU-J

Cable length exceeding 10 m on request

(1) = n°. câbles x (n°. conducteurs câble x section [mm²]) x longueur câble [m] - Câble NSSHÖU-J

Sur demande longueur de câble supérieure à 10 m

(1) = n°. cavi x (n°. conduttori per cavo x sezione [mm²]) x lunghezza cavo [m] - Cavo NSSHÖU-J

Lunghezza cavo superiore a 10 m - su richiesta

Electric pump type <i>Electropompe type</i> Elettropompa tipo	Curve <i>Courbe</i> Curva	Motor power <i>Puiss. moteur</i> Potenza motore	Capacity <i>Debit</i> Portata																	
			[l/s]	0	0,9	1	2	4	6	8	10	15	20	25	30	35	37			
			P ₂	[m ³ /h]	0	3,2	3,6	7,2	14,4	21,6	28,8	36	54	72	90	108	126	133,2		
			(N°)	[kW]	Head <i>Hauteur</i> Prevalenza															
				[m]	25,5	25,2	25,2	24,9	24	22,9	21,6	20,3	16,9	13,5	10,4	7,6	4,9	3,9		
KCW080HW+009022N3	1	9		[m]	25,5	25,2	25,2	24,9	24	22,9	21,6	20,3	16,9	13,5	10,4	7,6	4,9	3,9		
KCW080HT+009022N3	2	9		[m]	26,6	26,3	26,3	25,9	25,1	24	22,9	21,6	18	14,5	11,2	8,3				
KCW080HR+009022N3	3	9		[m]	30,7	30,4	30,4	30,1	29,2	28	26,8	25,4	21,6	17,7	13,9	10,3				
KCW080HQ+009022N3	4	9		[m]	33	32,7	32,7	32,3	31,4	30,2	28,8	27,2	23,1	19	15					
KCW080HP+009022N3	5	9		[m]	28,7	28,4	28,4	28,1	27,2	26,2	25	23,6	19,9	16	12,5	9,4				
KCW080HN+009022N3	6	9		[m]	34,9	34,8	34,7	34,5	33,5	32	30,4	28,9	25,6							
NPSH _R				[m]				2	2	2	2,1	2,1	2,2	2,3	2,5	2,6	2,9	3		

P₂ = Power rated by the motor

Performance tolerance as per:
UNI/ISO 9906 Grade 3B

For motor performances specification see page "motor features"

For the accessories specification see page "Accessories"

The impellers will be trimmed to meet the duty point

P₂ = Puissance restituée par le moteur

Tolérances sur les performances selon normes:
UNI/ISO 9906 Niveau 3B

Pour caractéristiques techniques moteurs voir page "Caractéristiques des moteurs"

Pour les accessoires voir page "Accessories"

Le point de fonctionnement désiré peut être obtenu par rognage de roue

P₂ = Potenza resa dal motore

Tolleranze sulle prestazioni secondo norme:
UNI/ISO 9906 Grado 3B

Per caratteristiche motori vedere pagina "caratteristiche motori"

Per accessori vedere pagina accessori

Le giranti vengono tornite in modo da ottenere il punto di lavoro richiesto

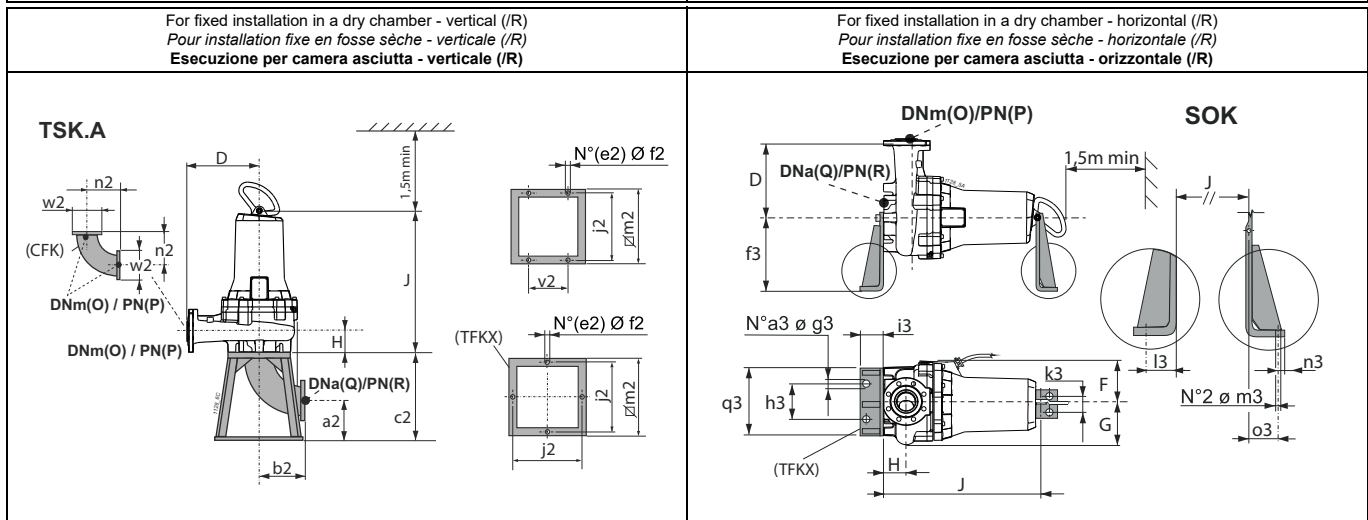
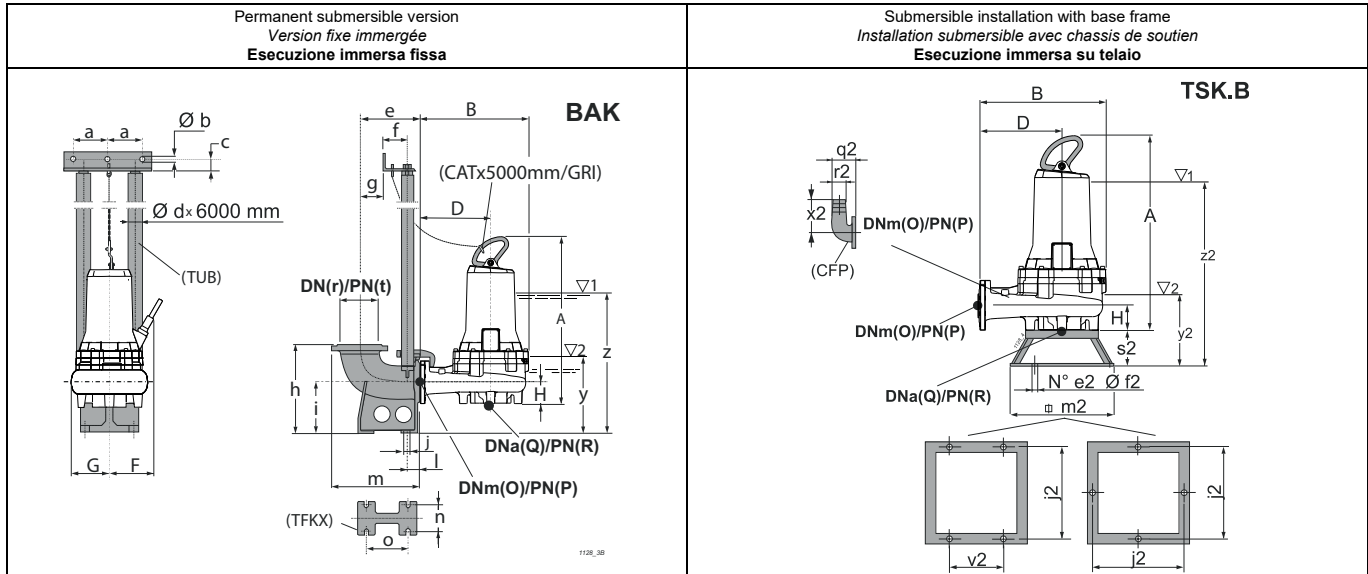

Type Type Tipo	Free passage Passage libre Passaggio Libero	Weight Poids Peso	[mm]											Accessories Accessoires Accessori			
			A	B	D	F	G	H	J	O	P	Q	R	BAK.	SOK.	TSK.A	TSK.B
KCW080HW+009022N3	Ø 80	116	707,4	392	245	221	146	92	589	80	16	80	16 (*)	F 2", G/F 2", F-A 2"	80/N3	K80	80
KCW080HT+009022N3	Ø 80	116,2	707,4	392	245	221	146	92	589	80	16	80	16 (*)	F 2", G/F 2", F-A 2"	80/N3	K80	80
KCW080HR+009022N3	Ø 80	116,2	707,4	392	245	221	146	92	589	80	16	80	16 (*)	F 2", G/F 2", F-A 2"	80/N3	K80	80
KCW080HQ+009022N3	Ø 80	116,6	707,4	392	245	221	146	92	589	80	16	80	16 (*)	F 2", G/F 2", F-A 2"	80/N3	K80	80
KCW080HP+009022N3	Ø 80	116	707,4	392	245	221	146	92	589	80	16	80	16 (*)	F 2", G/F 2", F-A 2"	80/N3	K80	80
KCW080HN+009022N3	Ø 80	116,4	707,4	392	245	221	146	92	589	80	16	80	16 (*)	F 2", G/F 2", F-A 2"	80/N3	K80	80

BAK.		a	b	c	d	e	f	g	h	i	j	l	m	n	o	r	t	y	z	
BAKF 2"		130	12,5	35	2"	220	102	40	320	180	18	47	320	110	156	80	ex PN10	277	529	
BAKG/F 2"		130	12,5	35	2"	228	102	48	320	180	18	47	338	110	156	100	16	277	529	
BAKF-A 2"		130	12,5	35	2"	220	102	40	320	180	18	47	320	110	156	80	16	277	529	
SOK.		a3	f3	g3	h3	i3	k3	l3	m3	n3	o3	q3								
SOK80/N3		2	400	22	270	100	100	66	22	34	43	400								
TSK.A		a2	b2	c2	e2	f2	j2	m2	n2	v2	w2									
TSKK80A		126	164	290	4	12	390	440	164	230	200									
TSK.B		e2	f2	j2	m2	q2	r2	s2	v2	x2	y2	z2								
TSK80B		4	12	400	440	165	75	166	230	217	355	607								

(3) z = Minimum submergence depth for motor without casing with continuous duty S1 (NPSHR permitting) (3) z = Immersion minimum pour moteur sans chemise en service continu S1 (compatible avec le NPSHR) (3) z = Immersion minima per motore senza mantello in funzione continuo S1 compatibilmente con l'NPSHR

y = Minimum submergence depth for motor without casing with intermittent duty S3 (NPSHR permitting) y = Immersion minimum pour moteur sans chemise en service intermittent S3 (compatible avec le NPSHR) y = Immersion minima con motore senza mantello in funzione intermittente S3 compatibilmente con l'NPSHR

(*) Consult the flanges page. (*) Voir page brides. (*) Vedere pagina flange.

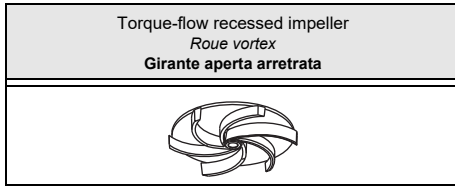

Type Type Tipo	KCW080L...+...22N3	KCW080L...+...22X3
Thermal probes Sondes termiques Sonde termiche	Yes Oui Sì	Yes Oui Sì
Conductivity probe Sonde de conductivité Sonda di conduttività	Yes Oui Sì	Yes Oui Sì

Version cable (1)
Version câble (1)
Cavo Versione (1)

Electric pump type Electropompe type Elettropompa tipo	Power supply Alimentation Alimentazione	Auxiliary Auxiliaire Ausiliario
KCW080LR+012522N3	1x(10x2,5)x10	
KCW080LP+016522N3	1x(10x2,5)x10	
KCW080LL+016522N3	1x(10x2,5)x10	
KCW080LG+016522N3	1x(10x2,5)x10	
KCW080LD+016522N3	1x(10x2,5)x10	
KCW080LA+016522N3	1x(10x2,5)x10	

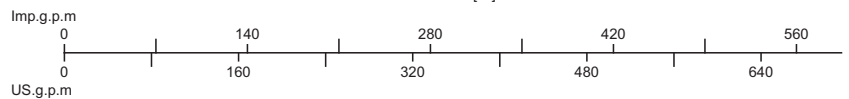
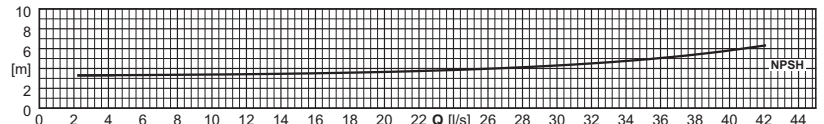
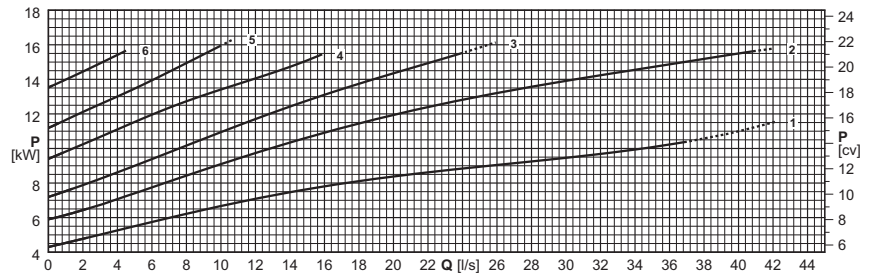
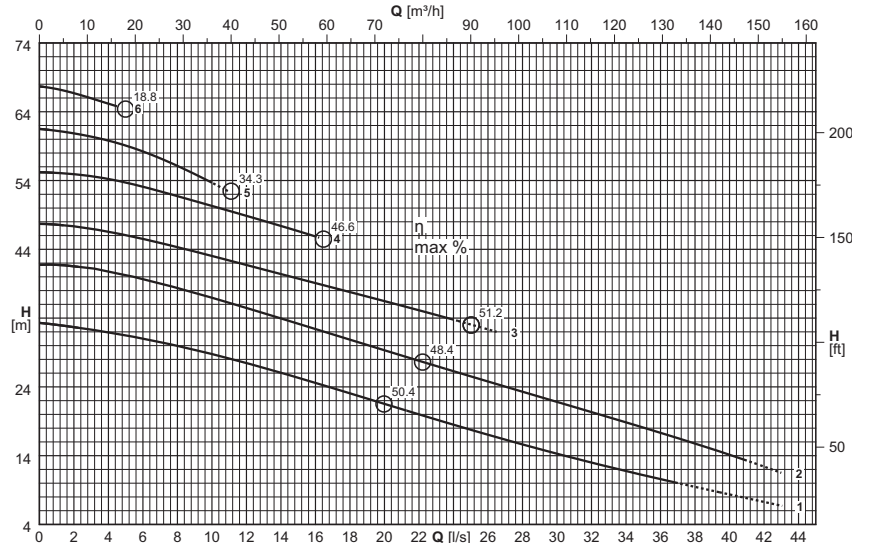

(1) = n°. of cables x (n°. of wires each cable x size [mm²]) x cable length [m] - Cable NSSHOU-J

Cable length exceeding 10 m on request

(1) = n°. câbles x (n°. conducteurs câble x section [mm²]) x longueur câble [m] - Câble NSSHOU-J

Sur demande longueur de câble supérieure à 10 m

(1) = n°. cavi x (n°. conduttori per cavo x sezione [mm²]) x lunghezza cavo [m] - Cavo NSSHOU-J

Lunghezza cavo superiore a 10 m - su richiesta

Electric pump type Electropompe type Elettropompa tipo	Curve Courbe Curva	Motor power Puiss. moteur Potenza motore	Capacity Débit Portata																			
			[l/s]	0	0,3	0,4	0,6	0,8	1	2	4	6	8	10	15	20	25	30	35	40	43	
			P ₂	[m ³ /h]	0	1,1	1,4	2,2	2,9	3,6	7,2	14,4	21,6	28,8	36	54	72	90	108	126	144	154,8
			(N°)	[kW]	Head Hauteur Prevalenza																	
			[m]	[m]	33,3	33,2	33,2	33,1	33,1	33	32,7	31,9	31	29,9	28,7	25,3	21,5	17,8	14,3	11,2	8,4	6,7
KCW080LR+012522N3	1	12,5	[m]	[m]	41,8	41,7	41,7	41,7	41,6	41,6	41,5	40,7	39,6	38,3	36,9	33,2	29,3	25,5	21,8	18,1	14,1	11,5
KCW080LP+016522N3	2	16,5	[m]	[m]	47,7	47,7	47,6	47,6	47,6	47,5	47,3	46,5	45,5	44,3	43	39,7	36,5	33,1				
KCW080LL+016522N3	3	16,5	[m]	[m]	55,2	55,2	55,2	55,1	55,1	55,1	54,9	54,2	53,1	51,7	50,3	46,6						
KCW080LG+016522N3	4	16,5	[m]	[m]	61,5	61,4	61,4	61,4	61,3	61,2	60,8	59,8	58,2	56,1	53,7							
KCW080LD+016522N3	5	16,5	[m]	[m]	67,7	67,6	67,6	67,5	67,4	67,3	66,7	65,2	63,3	61,4	59,4							
KCW080LA+016522N3	6	16,5	[m]	[m]								3,3	3,3	3,4	3,4	3,5	3,7	3,9	4,3	4,9	5,8	6,6
NPSH _R			[m]	[m]																		

P₂ = Power rated by the motor

Performance tolerance as per:
UNI/ISO 9906 Grade 3B

For motor performances specification see page "motor features"

For the accessories specification see page "Accessories"

The impellers will be trimmed to meet the duty point

P₂ = Puissance restituée par le moteur

Tolérances sur les performances selon normes:
UNI/ISO 9906 Niveau 3B

Pour caractéristiques techniques moteurs voir page "Caractéristiques des moteurs"

Pour les accessoires voir page "Accessories"

Le point de fonctionnement désiré peut être obtenu par rognage de roue

P₂ = Potenza resa dal motore

Tolleranze sulle prestazioni secondo norme:
UNI/ISO 9906 Grado 3B

Per caratteristiche motori vedere pagina "caratteristiche motori"

Per accessori vedere pagina accessori

Le giranti vengono tornite in modo da ottenere il punto di lavoro richiesto

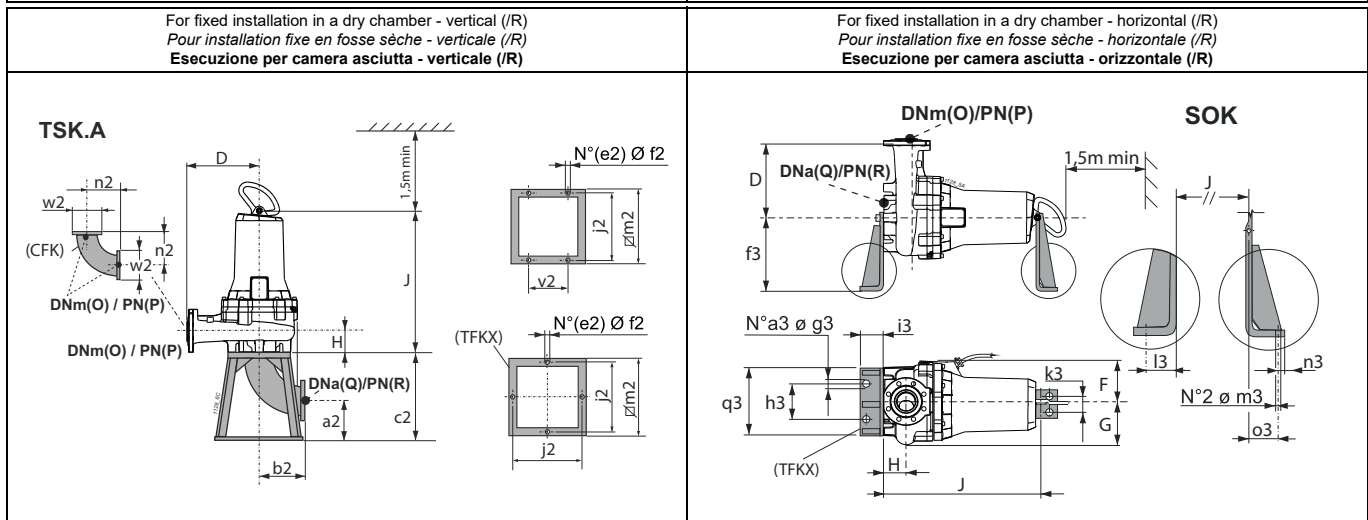
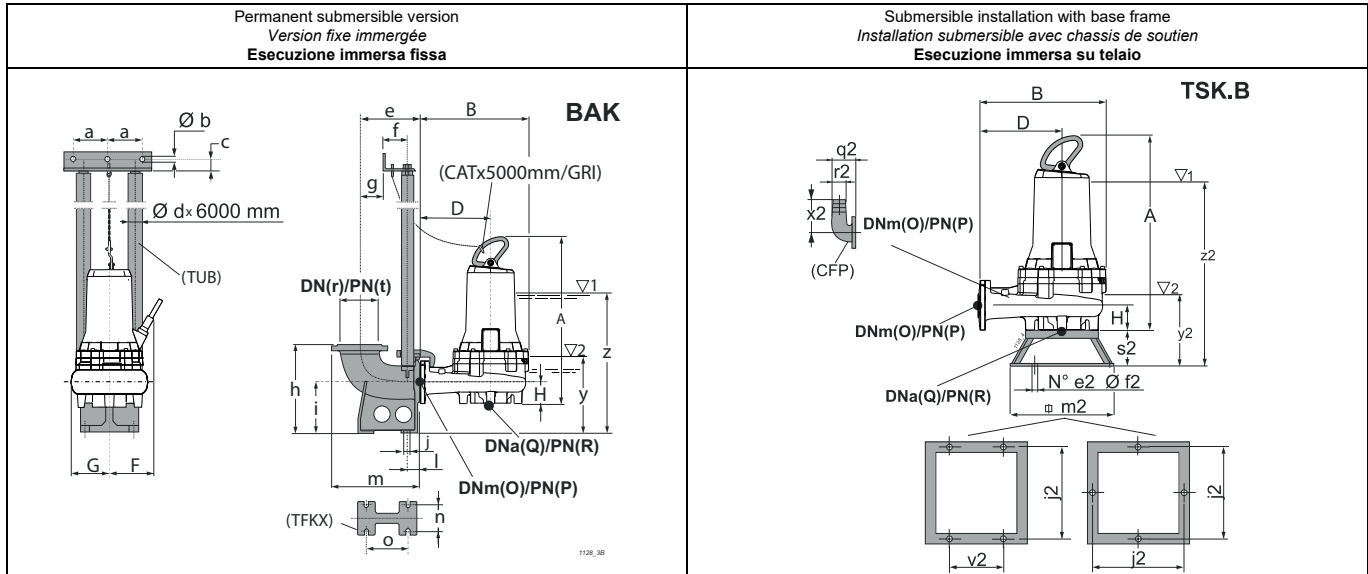

Type Type Tipo	Free passage Passage libre Passaggio Libero	Weight Poids Peso	[mm]											Accessories Accessoires Accessori					
			A	B	D	F	G	H	J	O	P	Q	R	BAK.	SOK.	TSK.A	TSK.B		
KCW080LR+012522N3	Ø 80	144,2	775	543	370	225,5	165	99	655,6	80	16	80	16 (*)	F 2", G/F 2", F-A 2"	80/N3	K80	80		
KCW080LP+016522N3	Ø 80	168,55	777,4	543	370	236,5	165	99	658	80	16	80	16 (*)	F 2", G/F 2", F-A 2"	80/N3	K80	80		
KCW080LL+016522N3	Ø 80	169,15	777,4	543	370	236,5	165	99	658	80	16	80	16 (*)	F 2", G/F 2", F-A 2"	80/N3	K80	80		
KCW080LG+016522N3	Ø 80	169,45	777,4	543	370	236,5	165	99	658	80	16	80	16 (*)	F 2", G/F 2", F-A 2"	80/N3	K80	80		
KCW080LD+016522N3	Ø 80	169,75	777,4	543	370	236,5	165	99	658	80	16	80	16 (*)	F 2", G/F 2", F-A 2"	80/N3	K80	80		
KCW080LA+016522N3	Ø 80	170,35	777,4	543	370	236,5	165	99	658	80	16	80	16 (*)	F 2", G/F 2", F-A 2"	80/N3	K80	80		
BAK.	a	b	c	d	e	f	g	h	i	j	l	m	n	o	r	t	y	z	
BAKF 2"	130	12,5	35	2"	220	102	40	320	180	18	47	320	110	156	80	ex PN10	278	626	
BAKG/F 2"	130	12,5	35	2"	228	102	48	320	180	18	47	338	110	156	100	16	278	626	
BAKF-A 2"	130	12,5	35	2"	220	102	40	320	180	18	47	320	110	156	80	16	278	626	
SOK.	a3	f3	g3	h3	i3	k3	l3	m3	n3	o3	q3								
SOK80/N3	2	400	22	270	100	100	66	22	34	43	400								
TSK.A	a2	b2	c2	e2	f2	j2	m2	n2	v2	w2									
TSKK80A	126	164	290	4	12	390	440	164	230	200									
TSK.B	e2	f2	j2	m2	q2	r2	s2	v2	x2	y2	z2								
TSK80B	4	12	400	440	165	75	166	230	217	363	711								

(3) z = Minimum submergence depth for motor without casing with continuous duty S1 (NPSHR permitting)
y = Minimum submergence depth for motor without casing with intermittent duty S3 (NPSHR permitting)
(*) Consult the flanges page.

(3) z = Immersion minimum pour moteur sans chemise en service continu S1 (compatible avec le NPSHR)
y = Immersion minimum pour moteur sans chemise en service intermittent S3 (compatible avec le NPSHR)
(*) Voir page brides.

(3) z = Immersion minima per motore senza mantello in funzione continuo S1 compatibilmente con l'NPSHR
y = Immersione minima con motore senza mantello in funzione intermittente S3 compatibilmente con l'NPSHR
(*) Vedere pagina flange.

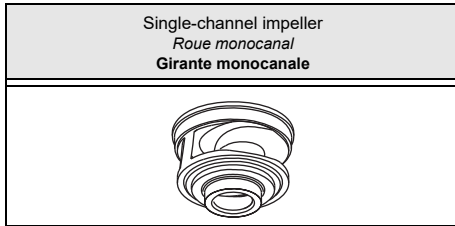

Type Type Tipo	KCM080L...+...22N3	KCM080L...+...22X3
Thermal probes Sondes thermiques Sonda termiche	Yes Oui Sì	Yes Oui Sì
Conductivity probe Sonde de conductivité Sonda di conduttività	Yes Oui Sì	Yes Oui Sì

Version cable (1)
Version câble (1)
Cavo Versione (1)

Electric pump type Electropompe type Elettropompa tipo	Power supply Alimentazione	Auxiliary Auxiliaire Ausiliario
KCM080LI+006522N3	1x(10x2,5)x10	
KCM080LG+006522N3	1x(10x2,5)x10	
KCM080LE+009022N3	1x(10x2,5)x10	
KCM080LC+012522N3	1x(10x2,5)x10	
KCM080LA+012522N3	1x(10x2,5)x10	
KCM080LP+016522N3	1x(10x2,5)x10	

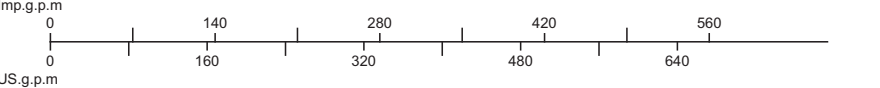
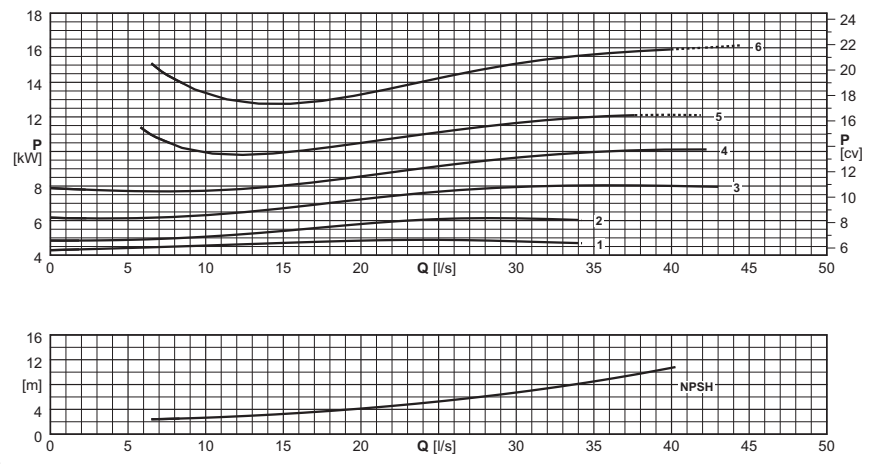
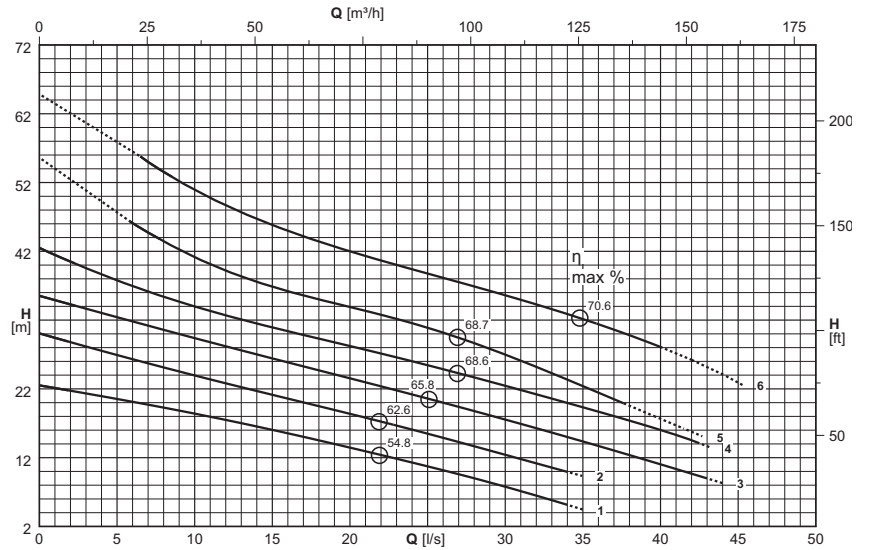

(1) = n°. of cables x (n°. of wires each cable x size [mm²]) x cable length [m] - Câble NSSHOU-J

Cable length exceeding 10 m on request

(1) = n°. câbles x (n°. conducteurs câble x section [mm²]) x longueur câble [m] - Câble NSSHOU-J

Sur demande longueur de câble supérieure à 10 m

(1) = n°. cavi x (n°. conduttori per cavo x sezione [mm²]) x lunghezza cavo [m] - Cavo NSSHOU-J

Lunghezza cavo superiore a 10 m - su richiesta

Electric pump type Electropompe type Elettropompa tipo	Curve Courbe Curva	Motor power Puiss. moteur Potenza motore	Capacity Débit Portata																
			[l/s]	0	2	4	6	8	10	15	20	25	30	35	40	45			
	(N°)	[kW]	[m ³ /h]	0	7,2	14,4	21,6	28,8	36	54	72	90	108	126	144	162			
				Head Hauteur Prevalenza															
			[m]	22,5	21,7	20,9	20,1	19,3	18,4	16	13,5	10,7	7,8	4,5					
KCM080LI+006522N3	1	6,5	[m]	22,5	21,7	20,9	20,1	19,3	18,4	16	13,5	10,7	7,8	4,5					
KCM080LG+006522N3	2	6,5	[m]	30,1	28,8	27,5	26,3	25,1	24	21,1	18,4	15,5	12,4						
KCM080LE+009022N3	3	9	[m]	35,5	34,3	33	31,8	30,6	29,4	26,4	23,5	20,6	17,5	14,4	11				
KCM080LC+012522N3	4	12,5	[m]	42,5	40,5	38,7	37	35,4	34	31	28,2	25,4	22,4	19,3	16				
KCM080LA+012522N3	5	12,5	[m]	53,6			46,1	43,5	41,2	36,9	33,9	30,9	27	22,4	17,6				
KCM080LP+016522N3	6	16,5	[m]	62,9				53,6	51	45,9	42	38,8	35,6	32,1	28,1	22,9			
NPSH _R			[m]					2,5	2,7	3,3	4,1	5,3	6,7	8,5	10,7				

P₂ = Power rated by the motor

Performance tolerance as per:
UNI/ISO 9906 Grade 3B

For motor performances specification see page "motor features"

For the accessories specification see page "Accessories"

P₂ = Puissance restituée par le moteur

Tolérances sur les performances selon normes:
UNI/ISO 9906 Niveau 3B

Pour caractéristiques techniques moteurs voir page "Caractéristiques des moteurs"

Pour les accessoires voir page "Accessories"

P₂ = Potenza resa dal motore

Tolleranze sulle prestazioni secondo norme:
UNI/ISO 9906 Grado 3B

Per caratteristiche motori vedere pagina "caratteristiche motori"

Per accessori vedere pagina accessori

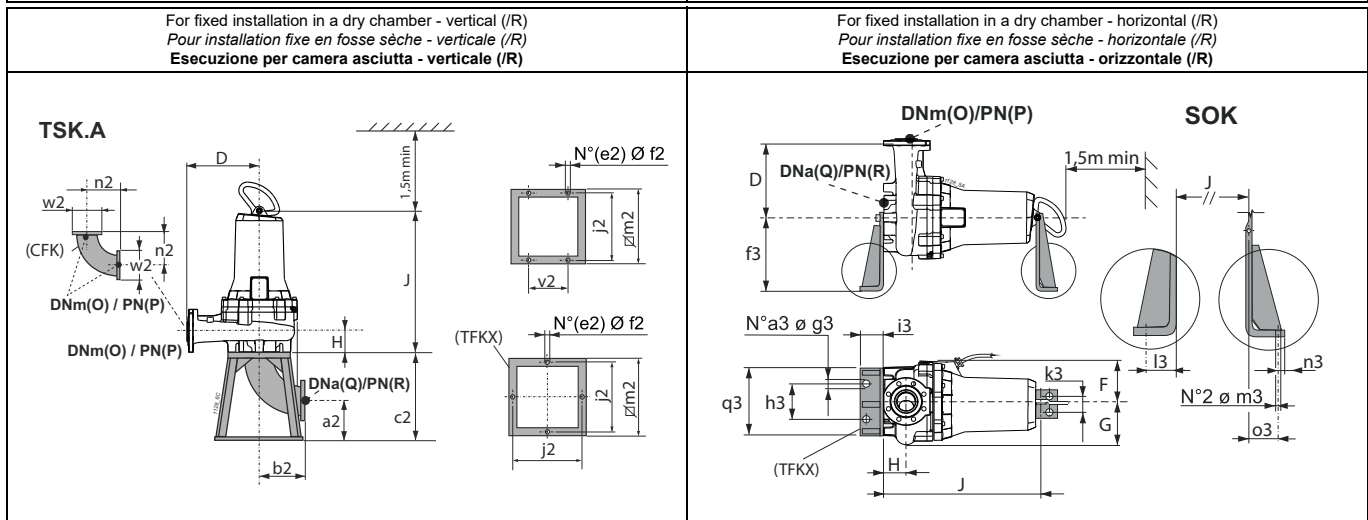
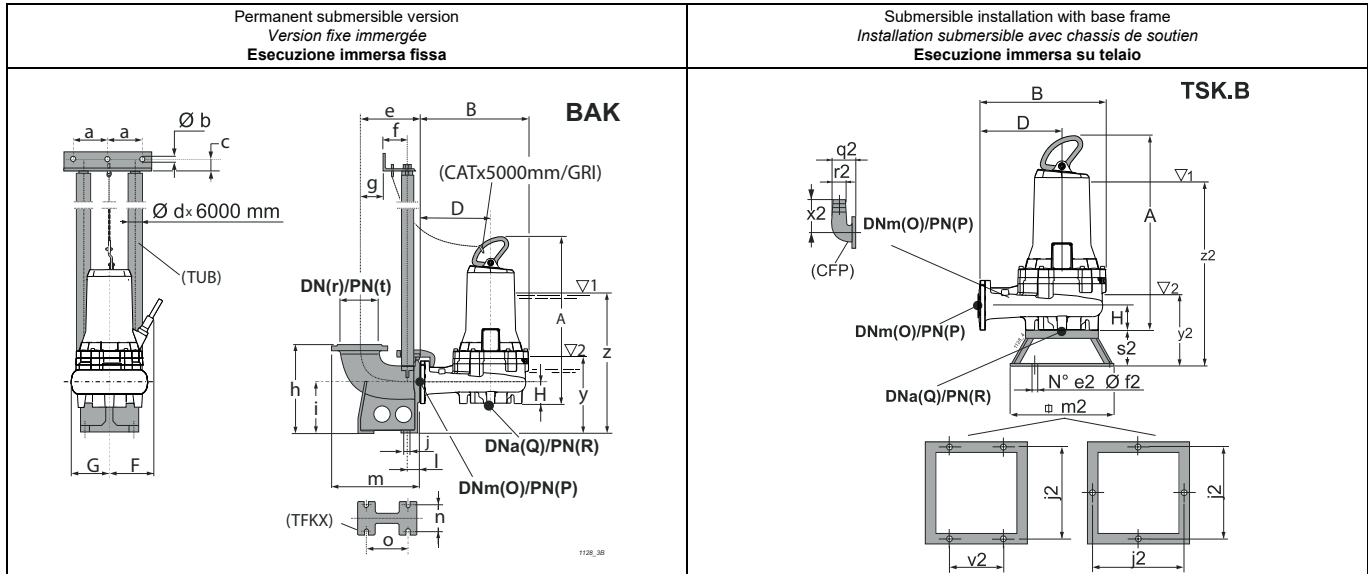

Type Type Tipo	Free passage Passage libre Passaggio Libero	Weight Poids Peso	[mm]												Accessories Accessoires Accessori					
			A	B	D	F	G	H	J	O	P	Q	R	BAK.	SOK.	TSK.A	TSK.B			
KCM080LI+006522N3	Ø 55	137,95	763	498	325	225,5	180	95	643,6	80	16	80	16 (*)	F 2", G/F 2", F-A 2"	80/N3	K80	80			
KCM080LG+006522N3	Ø 55	137,05	763	498	325	225,5	180	95	643,6	80	16	80	16 (*)	F 2", G/F 2", F-A 2"	80/N3	K80	80			
KCM080LE+009022N3	Ø 55	142,5	763	498	325	225,5	180	95	643,6	80	16	80	16 (*)	F 2", G/F 2", F-A 2"	80/N3	K80	80			
KCM080LC+012522N3	Ø 55	148,1	763	498	325	225,5	180	95	643,6	80	16	80	16 (*)	F 2", G/F 2", F-A 2"	80/N3	K80	80			
KCM080LA+012522N3	Ø 55	148,2	763	498	325	225,5	180	95	643,6	80	16	80	16 (*)	F 2", G/F 2", F-A 2"	80/N3	K80	80			
KCM080LP+016522N3	Ø 55	172,25	765,4	498	325	236,5	180	95	646	80	16	80	16 (*)	F 2", G/F 2", F-A 2"	80/N3	K80	80			
BAK.			a	b	c	d	e	f	g	h	i	j	l	m	n	o	r	t	y	z
BAKF 2"			130	12,5	35	2"	220	102	40	320	180	18	47	320	110	156	80	ex PN10	267	618
BAKG/F 2"			130	12,5	35	2"	228	102	48	320	180	18	47	338	110	156	100	16	267	618
BAKF-A 2"			130	12,5	35	2"	220	102	40	320	180	18	47	320	110	156	80	16	267	618
SOK.			a3	f3	g3	h3	i3	k3	l3	m3	n3	o3	q3							
SOK80/N3			2	400	22	270	100	100	66	22	34	43	400							
TSK.A			a2	b2	c2	e2	f2	j2	m2	n2	v2	w2								
TSKK80A			126	164	290	4	12	390	440	164	230	200								
TSK.B			e2	f2	j2	m2	q2	r2	s2	v2	x2	y2	z2							
TSK80B			4	12	400	440	165	75	166	230	217	348	699							

(3) z = Minimum submergence depth for motor without casing with continuous duty S1 (NPSHR permitting)
y = Minimum submergence depth for motor without casing with intermittent duty S3 (NPSHR permitting)
(*) Consult the flanges page.

(3) z = Immersion minimum pour moteur sans chemise en service continu S1 (compatible avec le NPSHR)
y = Immersion minimum pour moteur sans chemise en service intermittent S3 (compatible avec le NPSHR)
(*) Voir page brides.

(3) z = Immersion minima per motore senza mantello in funzione continuo S1 compatibilmente con l'NPSHR
y = Immersione minima con motore senza mantello in funzione intermittente S3 compatibilmente con l'NPSHR
(*) Vedere pagina flange.

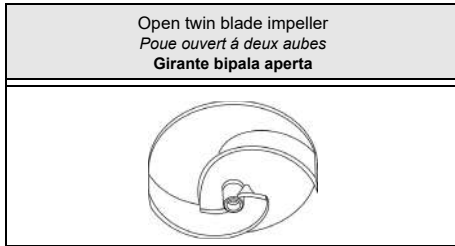

Type Type Tipo	KCA080L+...22N3	KCA080L+...22X3
Thermal probes Sondes thermiques Sonda termiche	Yes Oui Sì	Yes Oui Sì
Conductivity probe Sonde de conductivité Sonda di conduttività	Yes Oui Sì	Yes Oui Sì

Version cable (1)
Version câble (1)
Cavo Versione (1)

Electric pump type Electropompe type Elettropompa tipo	Power supply Alimentation Alimentazione	Auxiliary Auxiliaire Ausiliario
KCA080LI+006522N3	1x(10x2,5)x10	
KCA080LG+006522N3	1x(10x2,5)x10	
KCA080LE+009022N3	1x(10x2,5)x10	
KCA080LC+012522N3	1x(10x2,5)x10	
KCA080LA+016522N3	1x(10x2,5)x10	

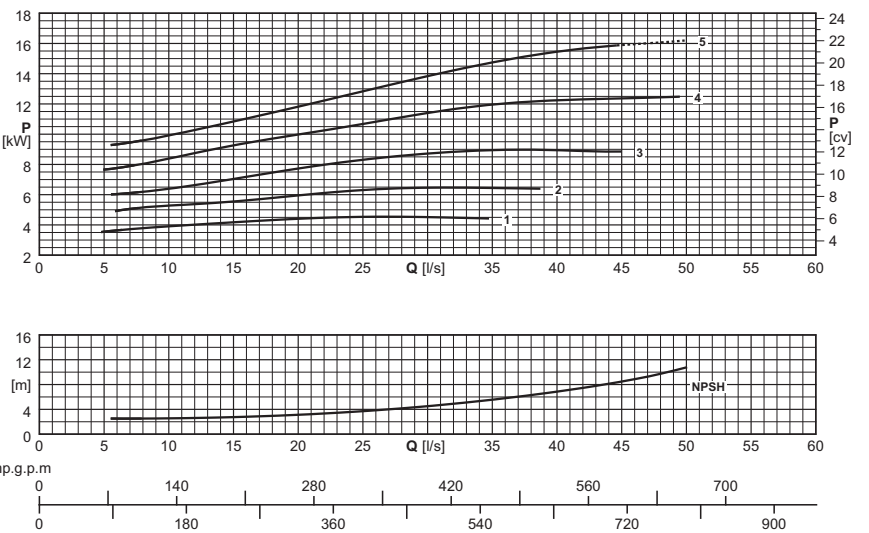
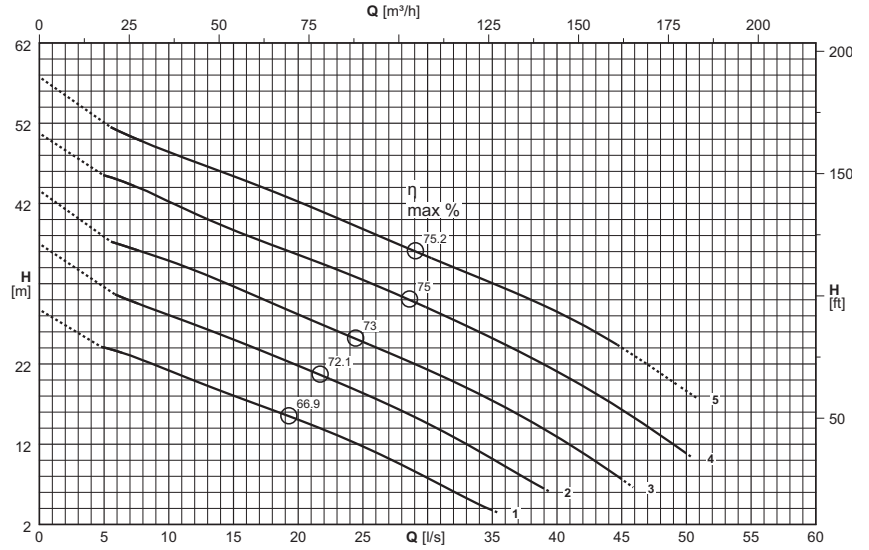

(1) = n°. of cables x (n°. of wires each cable x size [mm²]) x cable length [m] - Câble NSSHOU-J

Cable length exceeding 10 m on request

(1) = n°. câbles x (n°. conducteurs câble x section [mm²]) x longueur câble [m] - Câble NSSHOU-J

Sur demande longueur de câble supérieure à 10 m

(1) = n°. cavi x (n°. conduttori per cavo x sezione [mm²]) x lunghezza cavo [m] - Cavo NSSHOU-J

Lunghezza cavo superiore a 10 m - su richiesta

Electric pump type Electropompe type Elettropompa tipo	Curve Courbe Curva	Motor power Puiss. moteur Potenza motore	Capacity Débit Portata																
			[l/s]	0	5	6	8	10	15	20	25	30	35	40	45	50			
			P ₂	[m ³ /h]	0	18	21,6	28,8	36	54	72	90	108	126	144	162	180		
			(N°)	[kW]	Head Hauteur Prevalenza														
			[m]	26,8	24	23,6	22,5	21,2	18,1	15,1	11,7	7,8	3,8						
KCA080LI+006522N3	1	6,5	[m]	26,8	24	23,6	22,5	21,2	18,1	15,1	11,7	7,8	3,8						
KCA080LG+006522N3	2	6,5	[m]	35		30,6	29,3	28,1	25	21,8	18,4	14,6	10,2						
KCA080LE+009022N3	3	9	[m]	41,6		37	35,9	34,9	31,7	28,2	24,8	21,3	17,4	12,9	7,6				
KCA080LC+012522N3	4	12,5	[m]	48,8	45,5	44,9	43,7	42,2	38,7	35,6	32,5	29	25,2	21,1	16,3	10,8			
KCA080LA+016522N3	5	16,5	[m]	55,8		51,2	49,7	48,4	45,4	42,2	38,8	35,4	32,1	28,5	24	18,6			
NPSH _R			[m]			2,5	2,5	2,6	2,7	3,1	3,7	4,5	5,6	6,9	8,5	10,9			

P₂ = Power rated by the motor

Performance tolerance as per:

UNI/ISO 9906 Grade 3B

For motor performances specification see page "motor features"

For the accessories specification see page "Accessories"

The impellers will be trimmed to meet the duty point

P₂ = Puissance restituée par le moteur

Tolérances sur les performances selon normes:

UNI/ISO 9906 Niveau 3B

Pour caractéristiques techniques moteurs voir page "Caractéristiques des moteurs"

Pour les accessoires voir page "Accessories"

Le point de fonctionnement désiré peut être obtenu par rognage de roue

P₂ = Potenza resa dal motore

Tolleranze sulle prestazioni secondo norme:

UNI/ISO 9906 Grado 3B

Per caratteristiche motori vedere pagina "caratteristiche motori"

Per accessori vedere pagina accessori

Le giranti vengono tornite in modo da ottenere il punto di lavoro richiesto

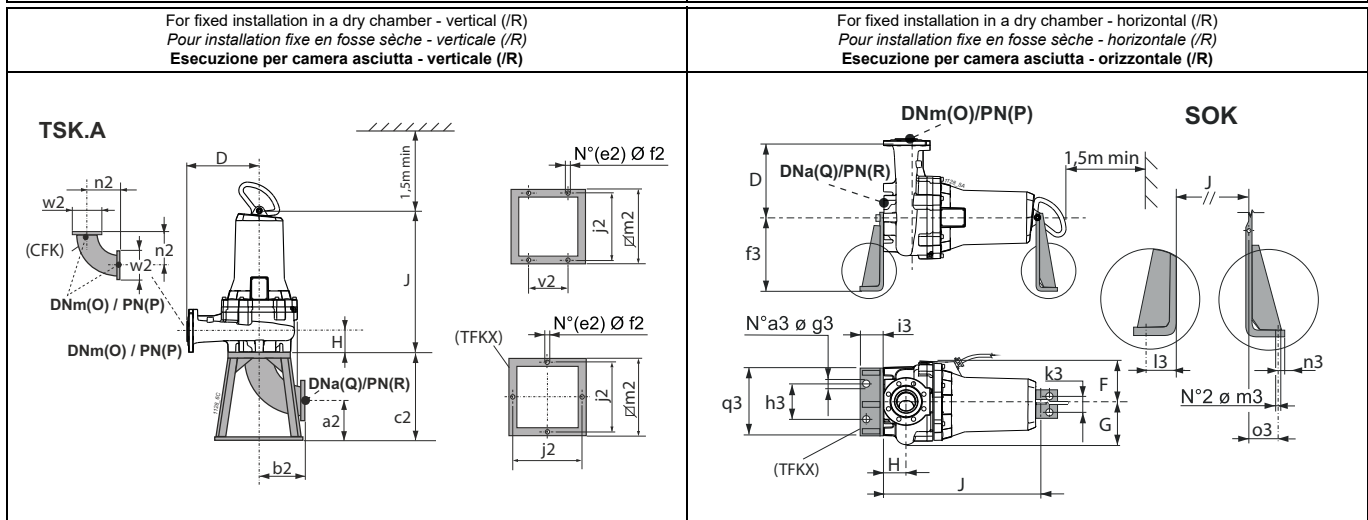
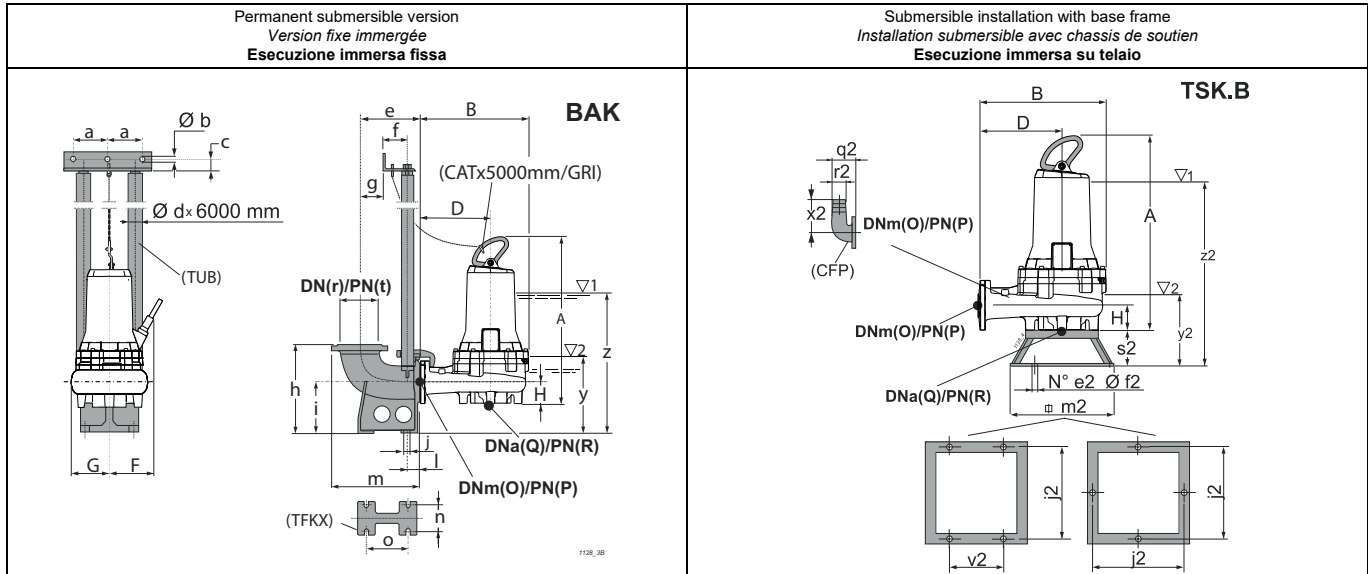

Type Type Tipo	Free passage Passage libre Passaggio Libero	Weight Poids Peso	A	B	D	F	G	H	J	O	P	Q	R	Accessories Accessoires Accessori			
			[mm]	[kg]	[mm]											BAK.	SOK.
KCA080LI+006522N3	---	138,21	748,4	496,5	320	236,7	166	98	629	80	16	80	16	F 2", G/F 2", F-A 2"	80/N3	K80	80
KCA080LG+006522N3	---	138,33	748,4	496,5	320	236,7	166	98	629	80	16	80	16	F 2", G/F 2", F-A 2"	80/N3	K80	80
KCA080LE+009022N3	---	143,08	748,4	496,5	320	236,7	166	98	629	80	16	80	16	F 2", G/F 2", F-A 2"	80/N3	K80	80
KCA080LC+012522N3	---	147,41	748,4	496,5	320	236,7	166	98	629	80	16	80	16	F 2", G/F 2", F-A 2"	80/N3	K80	80
KCA080LA+016522N3	---	171,67	750,8	496,5	320	236,7	166	98	631,4	80	16	80	16	F 2", G/F 2", F-A 2"	80/N3	K80	80

BAK.	a	b	c	d	e	f	g	h	i	j	l	m	n	o	r	y	z
BAKF 2"	130	12,5	35	2"	220	102	40	320	180	18	47	320	110	156	80	267	618
BAKG/F 2"	130	12,5	35	2"	228	102	48	320	180	18	47	338	110	156	100	16	618
BAKF-A 2"	130	12,5	35	2"	220	102	40	320	180	18	47	320	110	156	80	16	618

SOK.	a3	f3	g3	h3	i3	k3	l3	m3	n3	o3	q3
SOK80/N3	2	400	22	270	100	100	66	22	34	43	400

TSK.A	a2	b2	c2	e2	f2	j2	m2	n2	v2	w2
TSKK80A	126	164	290	4	12	390	440	164	230	200

TSK.B	e2	f2	j2	m2	q2	r2	s2	v2	x2	y2	z2
TSK80B	4	12	400	440	165	75	166	230	217	351	702

(3) z = Minimum submergence depth for motor without casing with continuous duty S1 (NPSHR permitting)

(3) z = Immersion minimum pour moteur sans chemise en service continu S1 (compatible avec le NPSHR)

(3) z = Immersion minima per motore senza mantello in funzione continuo S1 compatibilmente con l'NPSHR

y = Minimum submergence depth for motor without casing with intermittent duty S3 (NPSHR permitting)

y = Immersion minimum pour moteur sans chemise en service intermittent S3 (compatible avec le NPSHR)

y = Immersion minima con motore senza mantello in funzione intermittente S3 compatibilmente con l'NPSHR

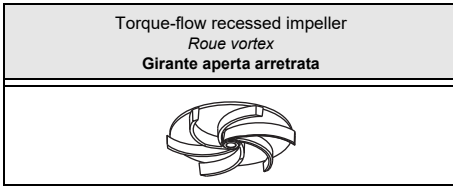

Type Type Tipo	KCW100L...61N3	KCW100L...61X3
Thermal probes Sondes termiques Sonde termiche	Yes Oui Sì	Yes Oui Sì
Conductivity probe Sonde de conductivité Sonda di conduttività	Yes Oui Sì	Yes Oui Sì

Version cable (1) <i>Version câble (1)</i> Cavo Versione (1)		
Electric pump type <i>Electropompe type</i> Elettropompa tipo	Power supply <i>Alimentation</i> Alimentazione	Auxiliary <i>Auxiliaire</i> Ausiliario
KCW100LE+004061N3	1x(7x1,5)x10	
KCW100LC+004061N3	1x(7x1,5)x10	
KCW100LA+004061N3	1x(7x1,5)x10	

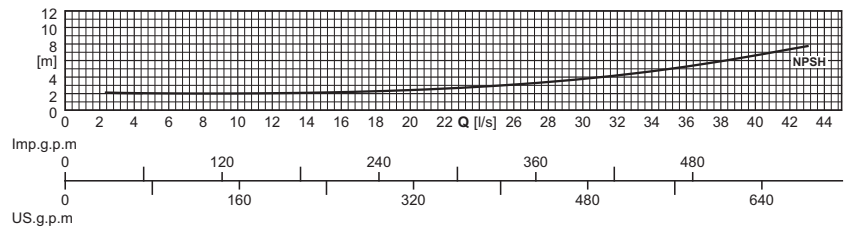
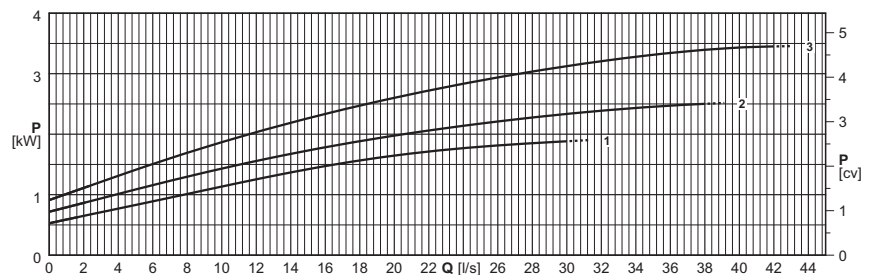
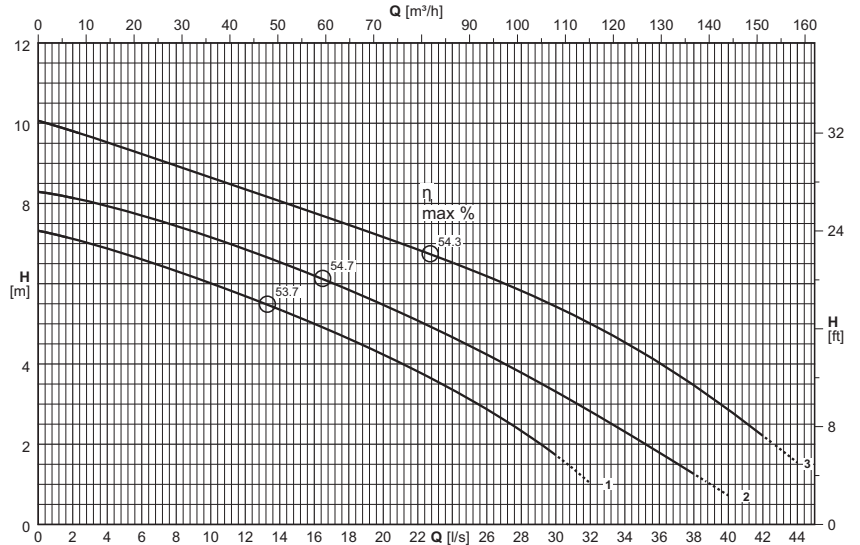

(1) = n°. of cables x (n°. of wires each cable x size [mm²]) x cable length [m] - Cable NSSHÖU-J

Cable length exceeding 10 m on request

(1) = n°. câbles x (n°. conducteurs câble x section [mm²]) x longueur câble [m] - Câble NSSHÖU-J

Sur demande longueur de câble supérieure à 10 m

(1) = n°. cavi x (n°. conduttori per cavo x sezione [mm²]) x lunghezza cavo [m] - Cavo NSSHÖU-J

Lunghezza cavo superiore a 10 m - su richiesta

Electric pump type <i>Electropompe type</i> Elettropompa tipo	Curve <i>Courbe</i> Curva	Motor power <i>Puiss. moteur</i> Potenza motore	Capacity <i>Debit</i> Portata															
			[l/s]	0	2	4	6	8	10	15	20	25	30	35	40	44		
		P ₂	[m³/h]	0	7,2	14,4	21,6	28,8	36	54	72	90	108	126	144	158,4		
	(N°)	[kW]	Head <i>Hauteur</i> Prevalenza															
KCW100LE+004061N3	1	4	[m]	7,3	7,1	6,9	6,6	6,3	6	5,2	4,2	3,1	1,7					
KCW100LC+004061N3	2	4	[m]	8,3	8,1	7,9	7,7	7,4	7,2	6,4	5,5	4,5	3,3	2,1	0,7			
KCW100LA+004061N3	3	4	[m]	10,1	9,8	9,5	9,2	8,9	8,6	7,9	7,2	6,4	5,4	4,3	2,9	1,5		
NPSH _R			[m]			2,1	2	2	2	2,1	2,4	3	3,8	5	6,6	8,1		

P₂ = Power rated by the motor

Performance tolerance as per: UNI/ISO 9906 Grade 3B

For motor performances specification see page "motor features"

For the accessories specification see page "Accessories"

The impellers will be trimmed to meet the duty point

P₂ = Puissance restituée par le moteur

Tolérances sur les performances selon normes: UNI/ISO 9906 Niveau 3B

Pour caractéristiques techniques moteurs voir page "Caractéristiques des moteurs"

Pour les accessoires voir page "Accessories"

Le point de fonctionnement désiré peut être obtenu par rognage de roue

P₂ = Potenza resa dal motore

Tolleranze sulle prestazioni secondo norme: UNI/ISO 9906 Grado 3B

Per caratteristiche motori vedere pagina "caratteristiche motori"

Per accessori vedere pagina accessori

Le giranti vengono tornite in modo da ottenere il punto di lavoro richiesto

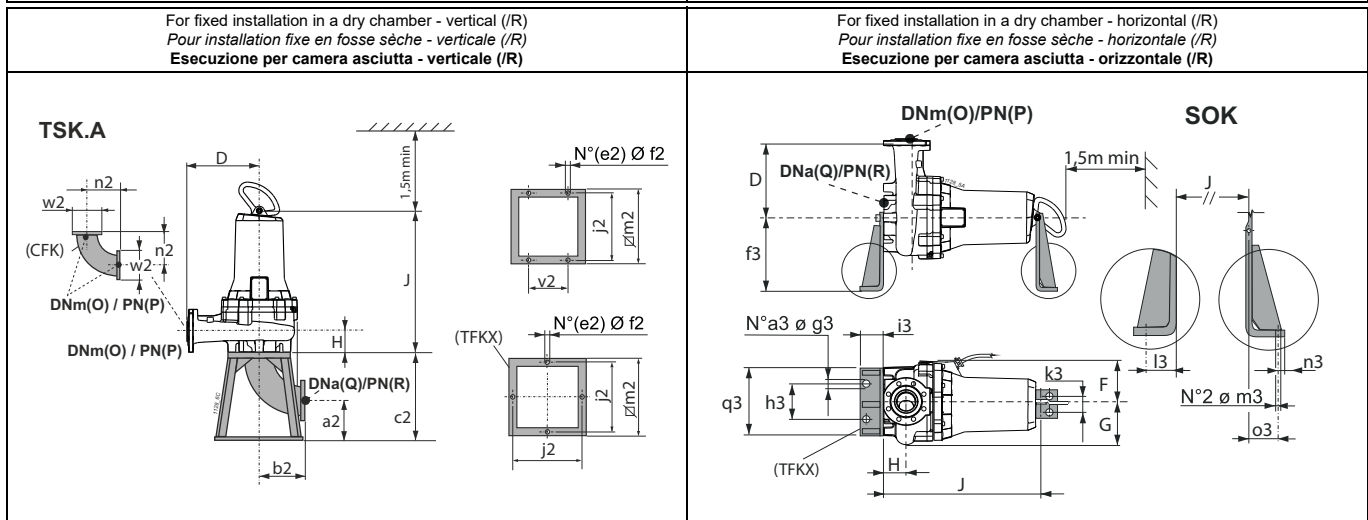
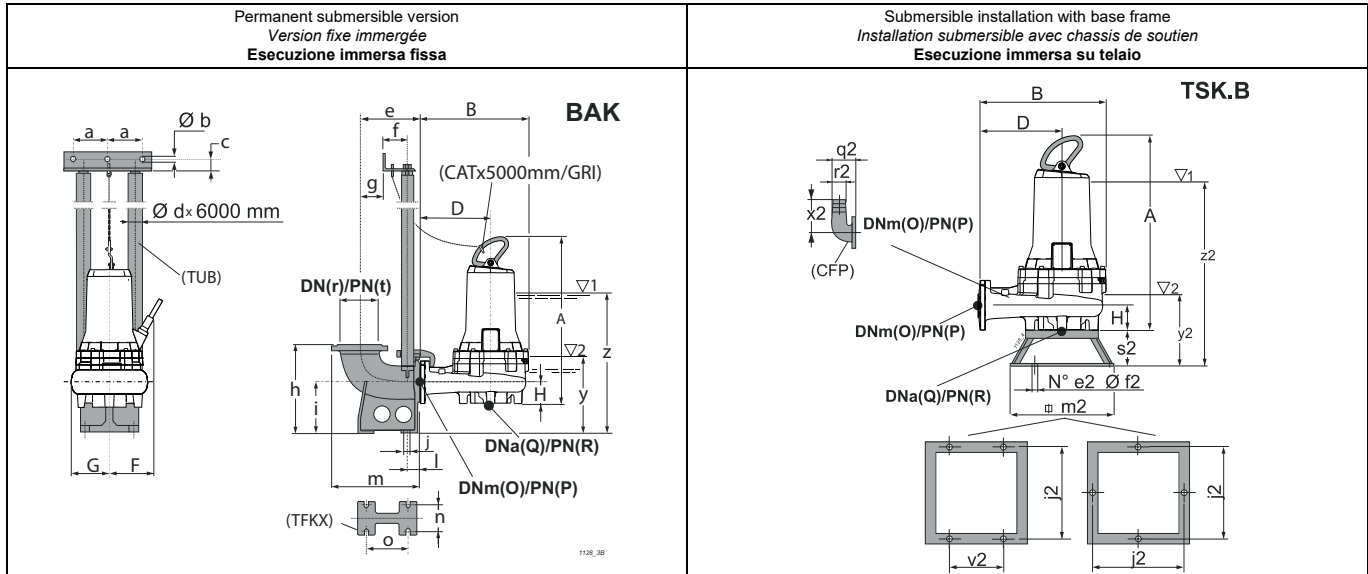

Type Type Tipo	Free passage Passage libre Passaggio Libero	Weight Poids Peso	A	B	D	F	G	H	J	O	P	Q	R	Accessories Accessoires Accessori				
	[mm]	[kg]	[mm]											BAK.	SOK.	TSK.A	TSK.B	
KCW100LE+004061N3	Ø 100	139,9	798	473	295	225,5	178,5	112	678,6	100	16	100	16	G 2"	100/N3	100	100	
KCW100LC+004061N3	Ø 100	140,3	798	473	295	225,5	178,5	112	678,6	100	16	100	16	G 2"	100/N3	100	100	
KCW100LA+004061N3	Ø 100	140,9	798	473	295	225,5	178,5	112	678,6	100	16	100	16	G 2"	100/N3	100	100	
BAK.	a	b	c	d	e	f	g	h	i	j	l	m	n	o	r	t	y	z
BAK G 2"	130	12,5	35	2"	228	102	48	350	200	18	49	338	135	186	100	16	306	668
SOK.	a3	f3	g3	h3	i3	k3	l3	m3	n3	o3	q3							
SOK 100/N3	2	400	22	320	100	100	66	22	34	43	470							
TSK.A	a2	b2	c2	e2	f2	j2	m2	n2	v2	w2								
TSK 100A	135	204	340	4	22	600	650	204	-	220								
TSK.B	e2	f2	j2	m2	q2	r2	s2	v2	x2	y2	z2							
TSK 100B	4	14	600	650	215	100	180	350	273	398	760							

(3) z = Minimum submergence depth for motor without casing with continuous duty S1 (NPSHR permitting)
y = Minimum submergence depth for motor without casing with intermittent duty S3 (NPSHR permitting)

(3) z = Immersion minimum pour moteur sans chemise en service continu S1 (compatible avec le NPSHR)
y = Immersion minimum pour moteur sans chemise en service intermittent S3 (compatible avec le NPSHR)

(3) z = Immersion minima per motore senza mantello in funzione continuo S1 compatibilmente con l'NPSHR
y = Immersione minima con motore senza mantello in funzione intermittente S3 compatibilmente con l'NPSHR

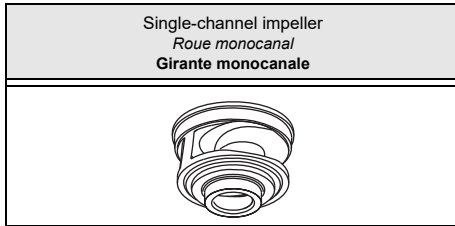

Type Type Tipo	KCM100H...+...61N3	KCM100H...+...61X3
Thermal probes <i>Sondes thermiques</i> Sonda termiche	Yes <i>Oui</i> Sì	Yes <i>Oui</i> Sì
Conductivity probe <i>Sonde de conductivité</i> Sonda di conduttività	Yes <i>Oui</i> Sì	Yes <i>Oui</i> Sì

Version cable (1)
Version câble (1)
Cavo Versione (1)

Electric pump type <i>Electropompe type</i> Elettropompa tipo	Power supply <i>Alimentation</i> Alimentazione	Auxiliary <i>Auxiliaire</i> Ausiliario
KCM100HL+001561N3	1x(7x1,5)x10	
KCM100HG+001561N3	1x(7x1,5)x10	
KCM100HD+001861N3	1x(7x1,5)x10	
KCM100HA+001861N3	1x(7x1,5)x10	

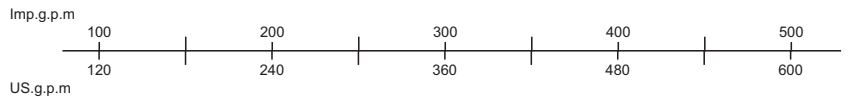
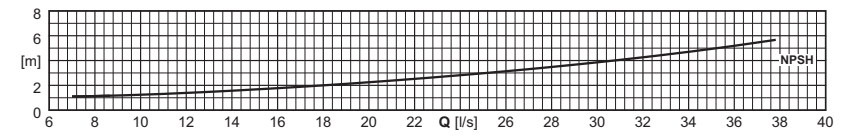
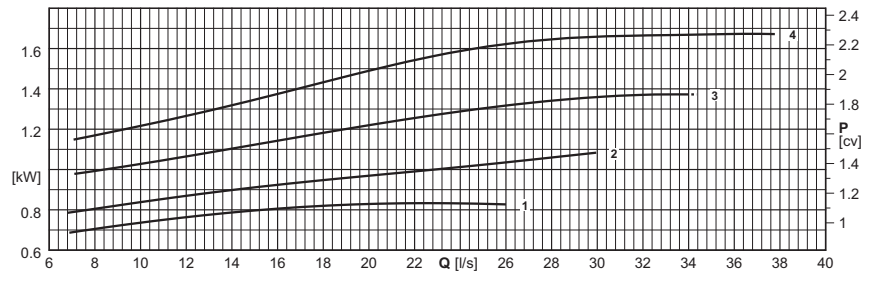
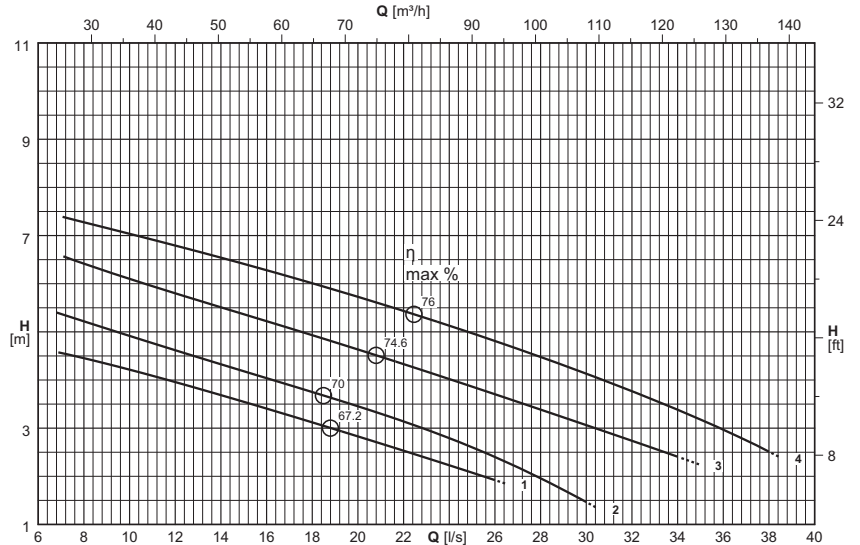

(1) = n°. of cables x (n°. of wires each cable x size [mm²]) x cable length [m] - Cable NSSHÖU-J

Cable length exceeding 10 m on request

(1) = n°. câbles x (n°. conducteurs câble x section [mm²]) x longueur câble [m] - Câble NSSHÖU-J

Sur demande longueur de câble supérieure à 10 m

(1) = n°. cavi x (n°. conduttori per cavo x sezione [mm²]) x lunghezza cavo [m] - Cavo NSSHÖU-J

Lunghezza cavo superiore a 10 m - su richiesta

Electric pump type <i>Electropompe type</i> Elettropompa tipo	Curve <i>Courbe</i> Curva	Motor power <i>Puiss. moteur</i> Potenza motore	Capacity <i>Debit</i> Portata																			
			[l/s]	0	6	7	8	9	10	12,5	15	17,5	20	22,5	25	27,5	30	32,5	35	37,5	38	
		P ₂	[m³/h]	0	21,6	25,2	28,8	32,4	36	45	54	63	72	81	90	99	108	117	126	135	136,8	
	(N°)	[kW]	Head <i>Hauteur</i> Prevalenza																			
			[m]	5,4	4,7	4,6	4,5	4,3	4,2	3,9	3,5	3,2	2,8	2,5	2,1							
KCM100HL+001561N3	1	1,5	[m]	5,4	4,7	4,6	4,5	4,3	4,2	3,9	3,5	3,2	2,8	2,5	2,1							
KCM100HG+001561N3	2	1,5	[m]	7,2	5,5	5,4	5,2	5,1	4,9	4,5	4,2	3,8	3,5	3,1	2,6	2,1	1,5					
KCM100HD+001861N3	3	1,8	[m]	8,7	6,8	6,6	6,4	6,3	6,1	5,7	5,4	5	4,6	4,3	3,9	3,5	3,1	2,7	2,2			
KCM100HA+001861N3	4	1,8	[m]	9,5	7,5	7,4	7,3	7,2	7	6,7	6,4	6,1	5,7	5,4	5	4,6	4,1	3,7	3,2	2,6	2,5	
NPSH _R			[m]			1,1	1,1	1,2	1,2	1,4	1,7	1,9	2,2	2,6	3	3,4	3,9	4,4	4,9	5,6	5,7	

P₂ = Power rated by the motor

Performance tolerance as per: UNI/ISO 9906 Grade 3B

For motor performances specification see page "motor features"

For the accessories specification see page "Accessories"

P₂ = Puissance restituée par le moteur

Tolérances sur les performances selon normes: UNI/ISO 9906 Niveau 3B

Pour caractéristiques techniques moteurs voir page "Caractéristiques des moteurs"

Pour les accessoires voir page "Accessories"

P₂ = Potenza resa dal motore

Tolleranze sulle prestazioni secondo norme: UNI/ISO 9906 Grado 3B

Per caratteristiche motori vedere pagina "caratteristiche motori"

Per accessori vedere pagina accessori

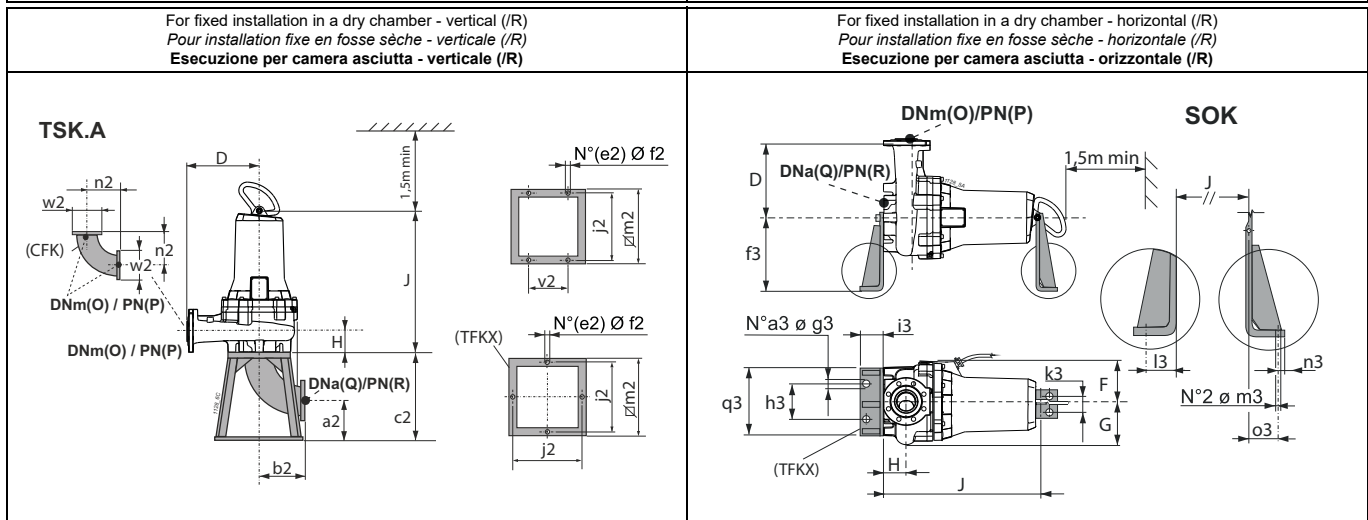
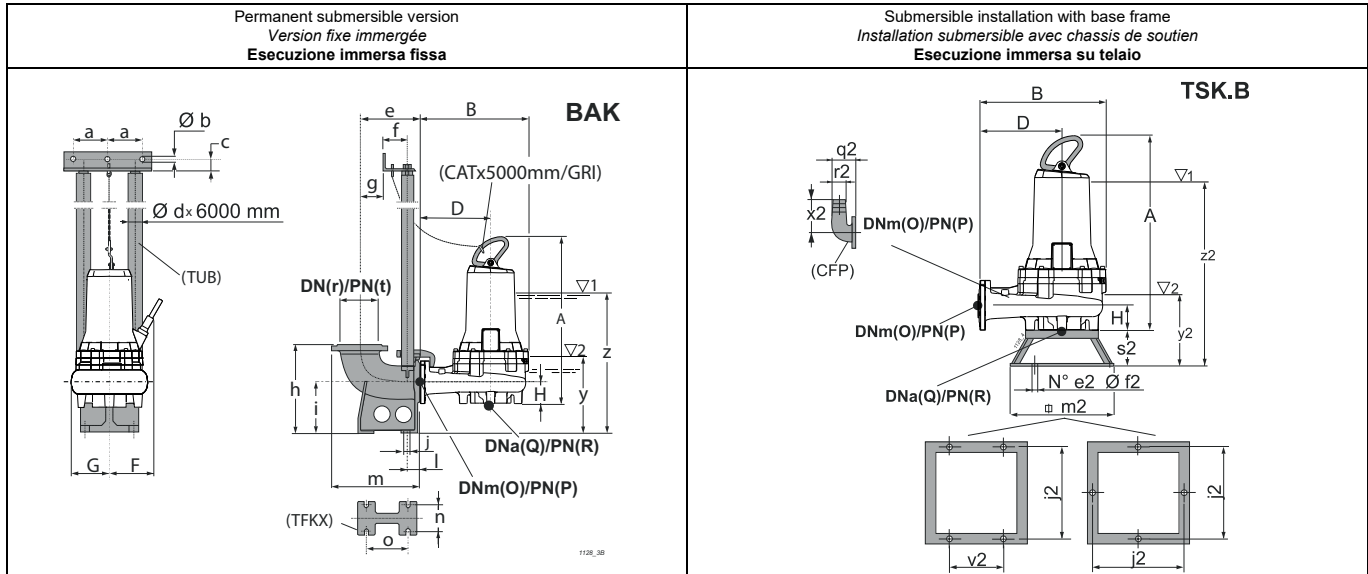

Type Type Tipo	Free passage Passage libre Passaggio Libero	Weight Poids Peso	A	B	D	F	G	H	J	O	P	Q	R	Accessories Accessoires Accessori			
			[mm]	[kg]	[mm]											BAK.	SOK.
KCM100HL+001561N3	Ø 80	94,7	650,3	435	255	204,5	198	118	565	100	16	100	16	G 2"	100/N3	100	100
KCM100HG+001561N3	Ø 80	94,7	650,3	435	255	204,5	198	118	565	100	16	100	16	G 2"	100/N3	100	100
KCM100HD+001861N3	Ø 80	116	719,4	435	255	221	198	118	601	100	16	100	16	G 2"	100/N3	100	100
KCM100HA+001861N3	Ø 80	116	719,4	435	255	221	198	118	601	100	16	100	16	G 2"	100/N3	100	100

BAK.	a	b	c	d	e	f	g	h	i	j	l	m	n	o	r	t	y	z
BAKG 2"	130	12,5	35	2"	228	102	48	350	200	18	49	338	135	186	100	16	282	537
SOK.	a3	f3	g3	h3	i3	k3	l3	m3	n3	o3	q3							
SOK100/N3	2	400	22	320	100	100	66	22	34	43	470							
TSK.A	a2	b2	c2	e2	f2	j2	m2	n2	v2	w2								
TSK100A	135	204	340	4	22	600	650	204	-	220								
TSK.B	e2	f2	j2	m2	q2	r2	s2	v2	x2	y2	z2							
TSK100B	4	14	600	650	215	100	180	350	273	380	635							

(3) z = Minimum submergence depth for motor without casing with continuous duty S1 (NPSHR permitting)
 y = Minimum submergence depth for motor without casing with intermittent duty S3 (NPSHR permitting)

(3) z = Immersion minimum pour moteur sans chemise en service continu S1 (compatible avec le NPSHR)
 y = Immersion minimum pour moteur sans chemise en service intermittent S3 (compatible avec le NPSHR)

(3) z = Immersion minima per motore senza mantello in funzione continuo S1 compatibilmente con l'NPSHR
 y = Immersione minima con motore senza mantello in funzione intermittente S3 compatibilmente con l'NPSHR

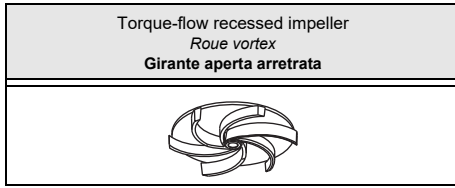

Type Type Tipo	KCW100H...41N3	KCW100H...41X3
Thermal probes Sondes termiques Sonda termiche	Yes Oui Sì	Yes Oui Sì
Conductivity probe Sonde de conductivité Sonda di conduttività	Yes Oui Sì	Yes Oui Sì

Version cable (1) Version câble (1) Cavo Versione (1)		
Electric pump type Electropompe type Elettropompa tipo	Power supply Alimentation Alimentazione	Auxiliary Auxiliaire Ausiliario
KCW100HR+002141N3	1x(7x1,5)x10	
KCW100HN+002941N3	1x(7x1,5)x10	
KCW100HL+003741N3	1x(7x1,5)x10	
KCW100HF+004641N3	1x(7x1,5)x10	
KCW100HA+005842N3	1x(10x2,5)x10	

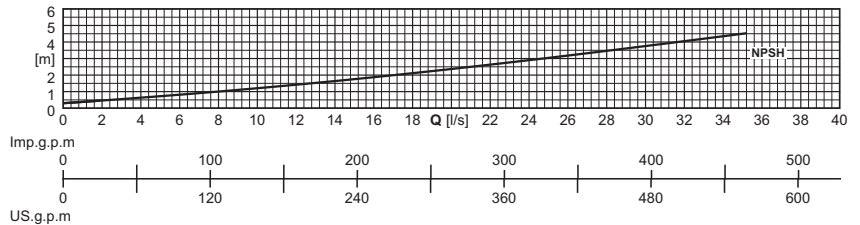
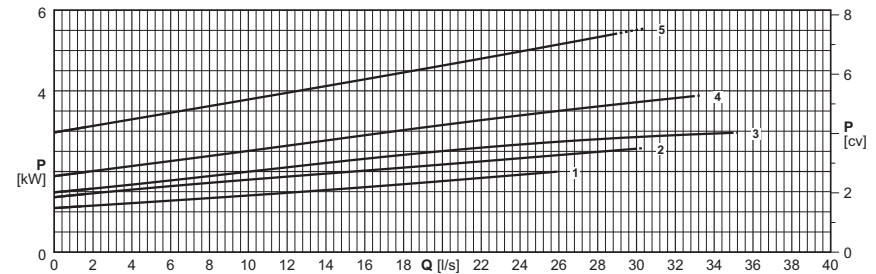
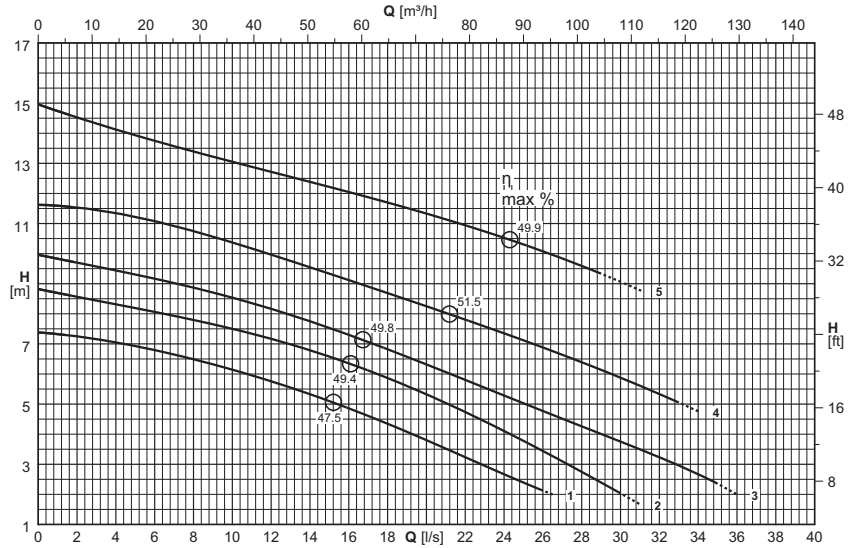

(1) = n°. of cables x (n°. of wires each cable x size [mm²]) x cable length [m] - Câble NSSHÖU-J

Cable length exceeding 10 m on request

(1) = n°. câbles x (n°. conducteurs câble x section [mm²]) x longueur câble [m] - Câble NSSHÖU-J

Sur demande longueur de câble supérieure à 10 m

(1) = n°. cavi x (n°. conduttori per cavo x sezione [mm²]) x lunghezza cavo [m] - Cavo NSSHÖU-J

Lunghezza cavo superiore a 10 m - su richiesta

Electric pump type Electropompe type Elettropompa tipo	Curve Courbe Curva	Motor power Puiss. moteur Potenza motore	Capacity Débit Portata																			
			[l/s]	0	2	4	6	8	10	12,5	15	17,5	20	22,5	25	27,5	30	32,5	35	36		
	(N°)	[kW]	P ₂	[m³/h]	0	7,2	14,4	21,6	28,8	36	45	54	63	72	81	90	99	108	117	126	129,6	
				Head Hauteur Prevalenza																		
			[m]	7,4	7,2	7	6,8	6,5	6,1	5,7	5,1	4,5	3,8	3,1	2,4							
KCW100HR+002141N3	1	2,1	[m]	7,4	7,2	7	6,8	6,5	6,1	5,7	5,1	4,5	3,8	3,1	2,4							
KCW100HN+002941N3	2	2,9	[m]	8,8	8,6	8,3	8,1	7,8	7,5	7,1	6,6	6	5,3	4,6	3,8	2,9	2					
KCW100HL+003741N3	3	3,7	[m]	10	9,7	9,4	9,2	8,9	8,5	8,1	7,5	6,9	6,3	5,7	5	4,4	3,8	3,1	2,3	2		
KCW100HF+004641N3	4	4,6	[m]	11,6	11,5	11,3	11,1	10,7	10,4	9,9	9,3	8,8	8,3	7,7	7,1	6,5	5,9	5,2				
KCW100HA+005842N3	5	5,8	[m]	15	14,5	14,1	13,8	13,4	13,1	12,6	12,2	11,8	11,3	10,8	10,3	9,7	9,1					
NPSH _R			[m]		0,5	0,6	0,8	1	1,2	1,5	1,8	2,1	2,4	2,7	3	3,4	3,8	4,1	4,5	4,7		

P₂ = Power rated by the motor

Performance tolerance as per:
UNI/ISO 9906 Grade 3B

For motor performances specification see page "motor features"

For the accessories specification see page "Accessories"

The impellers will be trimmed to meet the duty point

P₂ = Puissance restituée par le moteur

Tolérances sur les performances selon normes:
UNI/ISO 9906 Niveau 3B

Pour caractéristiques techniques moteurs voir page "Caractéristiques techniques des moteurs"

Pour les accessoires voir page "Accessories"

Le point de fonctionnement désiré peut être obtenu par rognage de roue

P₂ = Potenza resa dal motore

Tolleranze sulle prestazioni secondo norme:
UNI/ISO 9906 Grado 3B

Per caratteristiche motori vedere pagina "caratteristiche motori"

Per accessori vedere pagina accessori

Le giranti vengono tornite in modo da ottenere il punto di lavoro richiesto

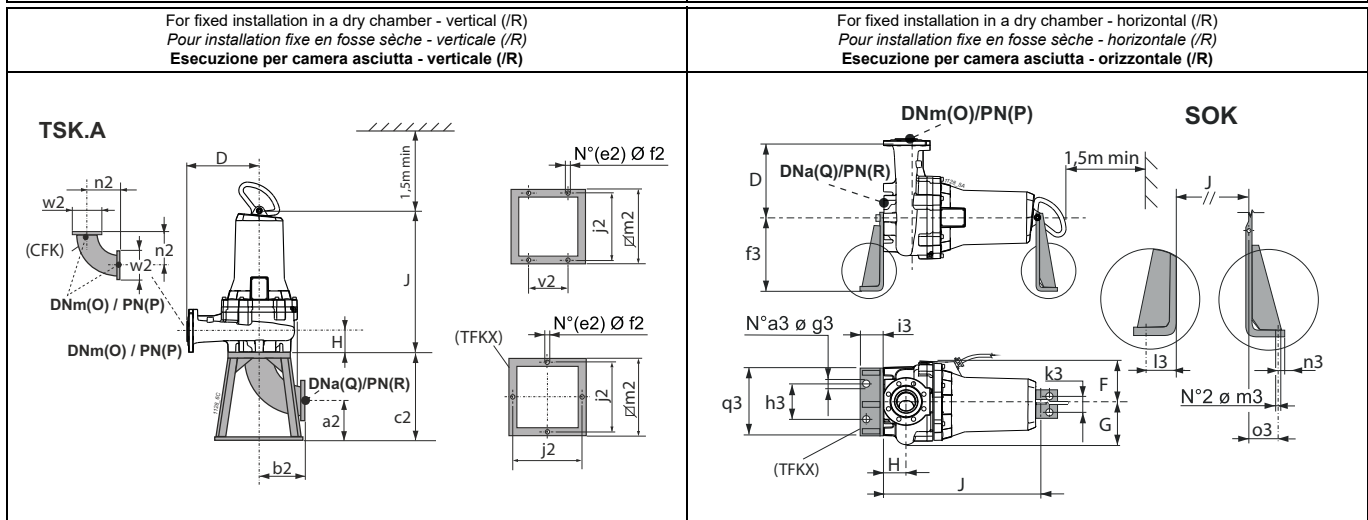
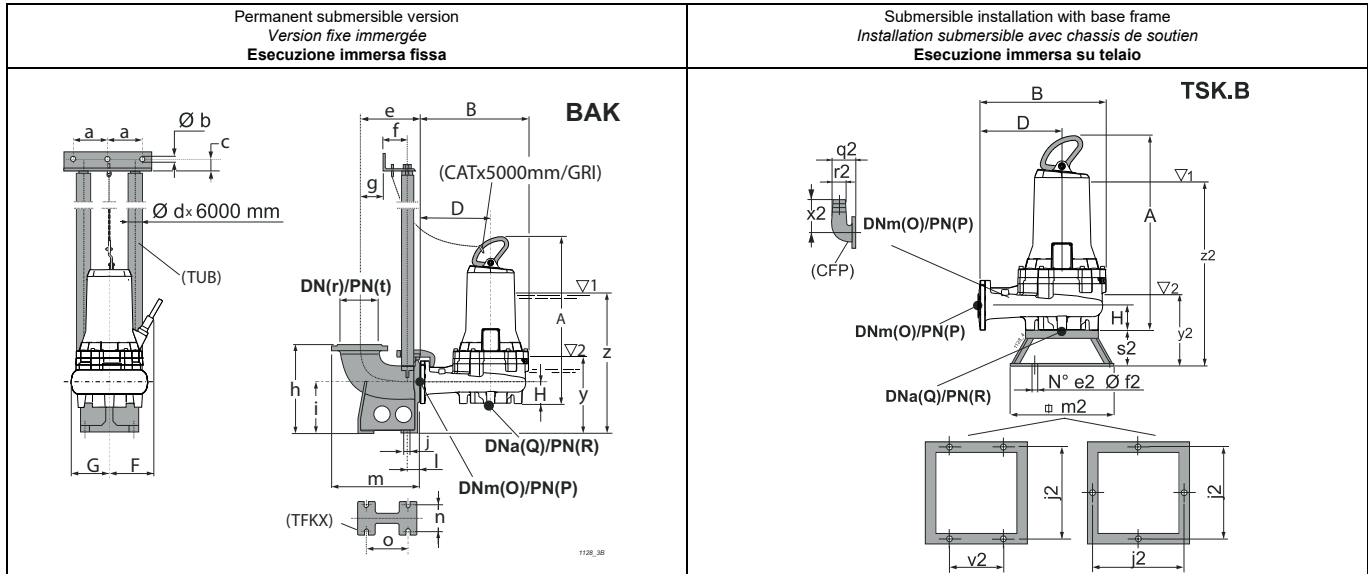

Type Type Tipo	Free passage Passage libre Passaggio Libero	Weight Poids Peso	A	B	D	F	G	H	J	O	P	Q	R	Accessories Accessoires Accessori				
			[mm]	[kg]	[mm]											BAK.	SOK.	TSK.A
KCW100HR+002141N3	Ø 100	96,6	668,3	434	263	204,5	171	112	583	100	16	100	16	G 2"	100/N3	100	100	
KCW100HN+002941N3	Ø 100	96,8	668,3	434	263	204,5	171	112	583	100	16	100	16	G 2"	100/N3	100	100	
KCW100HL+003741N3	Ø 100	111,3	737,4	434	263	221	171	112	619	100	16	100	16	G 2"	100/N3	100	100	
KCW100HF+004641N3	Ø 100	111,7	737,4	434	263	221	171	112	619	100	16	100	16	G 2"	100/N3	100	100	
KCW100HA+005842N3	Ø 100	121,2	737,4	434	263	221	171	112	619	100	16	100	16	G 2"	100/N3	100	100	
BAK.	a	b	c	d	e	f	g	h	i	j	l	m	n	o	r	t	y	z
BAKG 2"	130	12,5	35	2"	228	102	48	350	200	18	49	338	135	186	100	16	306	561
SOK.	a3	f3	g3	h3	i3	k3	l3	m3	n3	o3	q3							
SOK100/N3	2	400	22	320	100	100	66	22	34	43	470							
TSK.A	a2	b2	c2	e2	f2	j2	m2	n2	v2	w2								
TSK100A	135	204	340	4	22	600	650	204	-	220								
TSK.B	e2	f2	j2	m2	q2	r2	s2	v2	x2	y2	z2							
TSK100B	4	14	600	650	215	100	180	350	273	398	653							

(3) z = Minimum submergence depth for motor without casing with continuous duty S1 (NPSHR permitting)
 y = Minimum submergence depth for motor without casing with intermittent duty S3 (NPSHR permitting)

(3) z = Immersion minimum pour moteur sans chemise en service continu S1 (compatible avec le NPSHR)
 y = Immersion minimum pour moteur sans chemise en service intermittent S3 (compatible avec le NPSHR)

(3) z = Immersion minima per motore senza mantello in funzione continuo S1 compatibilmente con l'NPSHR
 y = Immersione minima con motore senza mantello in funzione intermittente S3 compatibilmente con l'NPSHR

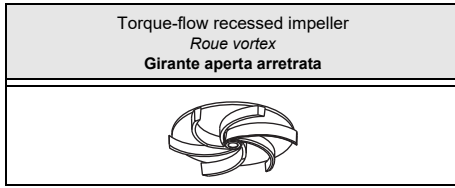

Type Type Tipo	KCW100L...+...42N3	KCW100L...+...42X3
Thermal probes Sondes termiques Sonde termiche	Yes Oui Sì	Yes Oui Sì
Conductivity probe Sonde de conductivité Sonda di conduttività	Yes Oui Sì	Yes Oui Sì

Version cable (1) <i>Version câble (1)</i> Cavo Versione (1)		
Electric pump type <i>Electropompe type</i> Elettropompa tipo	Power supply <i>Alimentation</i> Alimentazione	Auxiliary <i>Auxiliaire</i> Ausiliario
KCW100LE+007542N3	1x(10x2,5)x10	
KCW100LC+010542N3	1x(10x2,5)x10	
KCW100LA+012542N3	1x(10x2,5)x10	

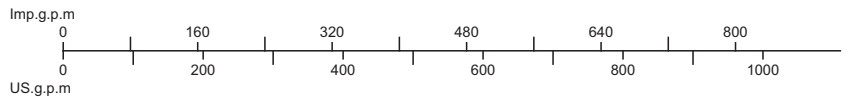
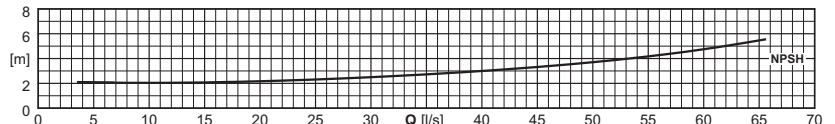
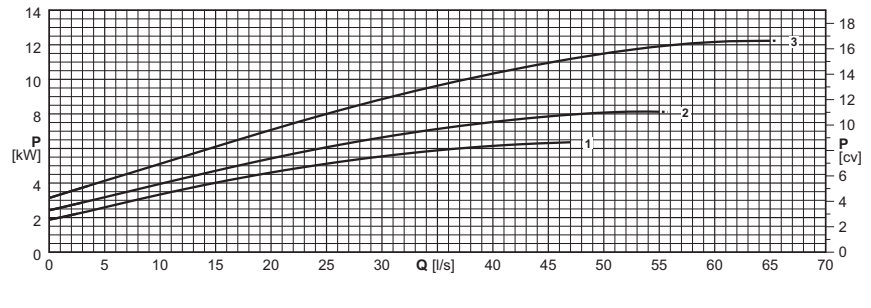
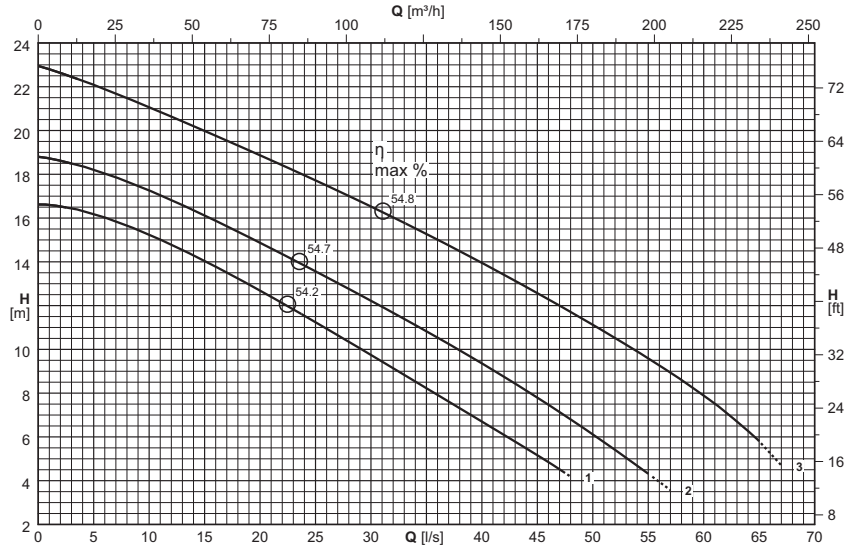

(1) = n°. of cables x (n°. of wires each cable x size [mm²]) x cable length [m] - Cable NSSHOU-J

Cable length exceeding 10 m on request

(1) = n°. câbles x (n°. conducteurs câble x section [mm²]) x longueur câble [m] - Câble NSSHOU-J

Sur demande longueur de câble supérieure à 10 m

(1) = n°. cavi x (n°. conduttori per cavo x sezione [mm²]) x lunghezza cavo [m] - Cavo NSSHOU-J

Lunghezza cavo superiore a 10 m - su richiesta

Electric pump type <i>Electropompe type</i> Elettropompa tipo	Curve <i>Courbe</i> Curva	Motor power <i>Puiss. moteur</i> Potenza motore	Capacity <i>Debit</i> Portata															
			[l/s]	0	3	5	10	15	20	25	30	35	40	45	50	60	67	
		P ₂	[m ³ /h]	0	10,8	18	36	54	72	90	108	126	144	162	180	216	241,2	
	(N°)	[kW]	Head <i>Hauteur</i> Prevalenza															
			[m]	16,6	16,4	16,2	15,2	14	12,7	11,2	9,7	8,2	6,7	5,2				
KCW100LE+007542N3	1	7,5	[m]	16,6	16,4	16,2	15,2	14	12,7	11,2	9,7	8,2	6,7	5,2				
KCW100LC+010542N3	2	10,5	[m]	18,8	18,5	18,2	17,2	16,1	14,9	13,6	12,2	10,8	9,4	7,8	6,1			
KCW100LA+012542N3	3	12,5	[m]	23	22,4	22,1	21,1	20	18,9	17,7	16,5	15,3	13,9	12,6	11,1	7,9	4,7	
NPSH _R			[m]			2,1	2	2,1	2,2	2,3	2,5	2,7	3	3,3	3,7	4,8	5,8	

P₂ = Power rated by the motor

Performance tolerance as per: UNI/ISO 9906 Grade 3B

For motor performances specification see page "motor features"

For the accessories specification see page "Accessories"

The impellers will be trimmed to meet the duty point

P₂ = Puissance restituée par le moteur

Tolérances sur les performances selon normes: UNI/ISO 9906 Niveau 3B

Pour caractéristiques techniques moteurs voir page "Caractéristiques des moteurs"

Pour les accessoires voir page "Accessories"

Le point de fonctionnement désiré peut être obtenu par rognage de roue

P₂ = Potenza resa dal motore

Tolleranze sulle prestazioni secondo norme: UNI/ISO 9906 Grado 3B

Per caratteristiche motori vedere pagina "caratteristiche motori"

Per accessori vedere pagina accessori

Le giranti vengono tornite in modo da ottenere il punto di lavoro richiesto

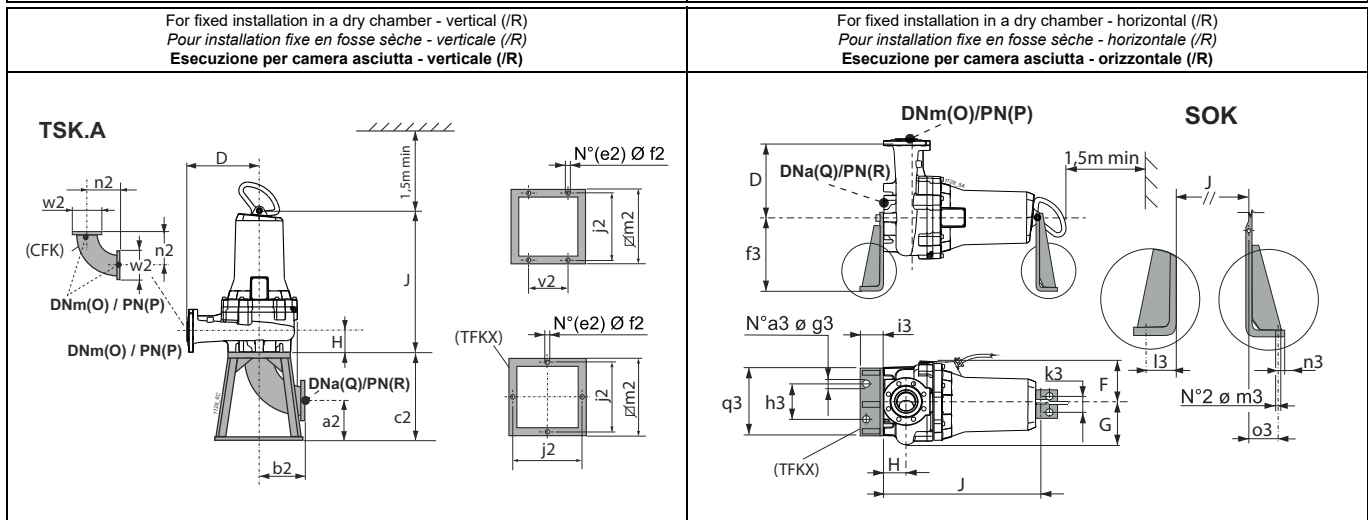
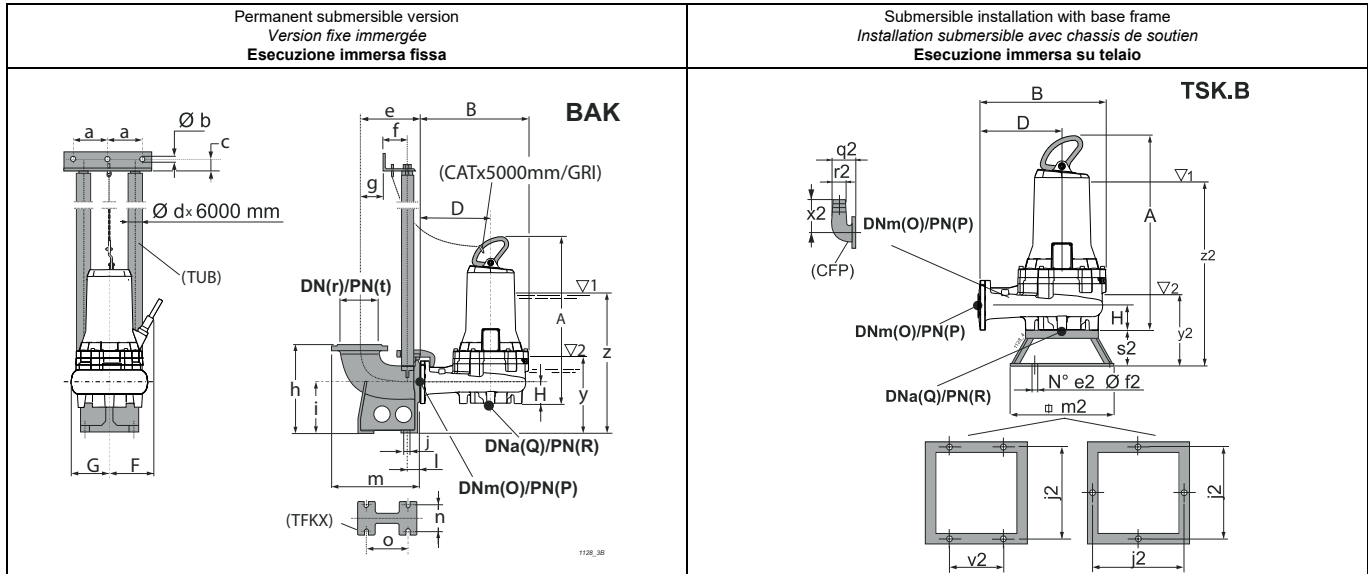

Type Type Tipo	Free passage Passage libre Passaggio Libero	Weight Poids Peso	A	B	D	F	G	H	J	O	P	Q	R	Accessories Accessoires Accessori				
	[mm]	[kg]	[mm]											BAK.	SOK.	TSK.A	TSK.B	
KCW100LE+007542N3	Ø 100	148,4	798	473	295	225,5	178,5	112	678,6	100	16	100	16	G 2"	100/N3	100	100	
KCW100LC+010542N3	Ø 100	172,05	800,4	473	295	236	178,5	112	681	100	16	100	16	G 2"	100/N3	100	100	
KCW100LA+012542N3	Ø 100	172,65	800,4	473	295	236,5	178,5	112	681	100	16	100	16	G 2"	100/N3	100	100	
BAK.	a	b	c	d	e	f	g	h	i	j	l	m	n	o	r	t	y	z
BAK G 2"	130	12,5	35	2"	228	102	48	350	200	18	49	338	135	186	100	16	306	668
SOK.	a3	f3	g3	h3	i3	k3	l3	m3	n3	o3	q3							
SOK 100/N3	2	400	22	320	100	100	66	22	34	43	470							
TSK.A	a2	b2	c2	e2	f2	j2	m2	n2	v2	w2								
TSK 100A	135	204	340	4	22	600	650	204	-	220								
TSK.B	e2	f2	j2	m2	q2	r2	s2	v2	x2	y2	z2							
TSK 100B	4	14	600	650	215	100	180	350	273	398	760							

(3) z = Minimum submergence depth for motor without casing with continuous duty S1 (NPSHR permitting)
y = Minimum submergence depth for motor without casing with intermittent duty S3 (NPSHR permitting)

(3) z = Immersion minimum pour moteur sans chemise en service continu S1 (compatible avec le NPSHR)
y = Immersion minimum pour moteur sans chemise en service intermittent S3 (compatible avec le NPSHR)

(3) z = Immersion minima per motore senza mantello in funzione continuo S1 compatibilmente con l'NPSHR
y = Immersione minima con motore senza mantello in funzione intermittente S3 compatibilmente con l'NPSHR

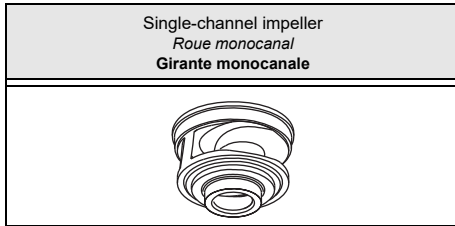

Type Type Tipo	KCM100H...41N3	KCM100H...41X3
Thermal probes <i>Sondes thermiques</i> Sonda termiche	Yes <i>Oui</i> Sì	Yes <i>Oui</i> Sì
Conductivity probe <i>Sonde de conductivité</i> Sonda di conduttività	Yes <i>Oui</i> Sì	Yes <i>Oui</i> Sì

Version cable (1)
Version câble (1)
Cavo Versione (1)

Electric pump type <i>Electropompe type</i> Elettropompa tipo	Power supply <i>Alimentation</i> Alimentazione	Auxiliary <i>Auxiliaire</i> Ausiliario
KCM100HL+002941N3	1x(7x1,5)x10	
KCM100HG+003741N3	1x(7x1,5)x10	
KCM100HD+004641N3	1x(7x1,5)x10	
KCM100HA+005842N3	1x(10x2,5)x10	

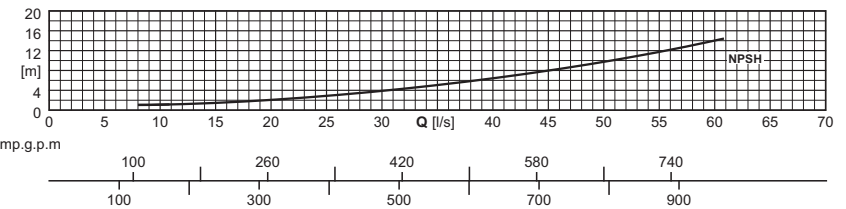
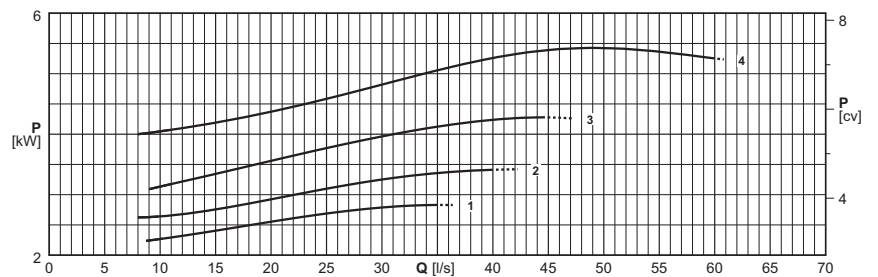
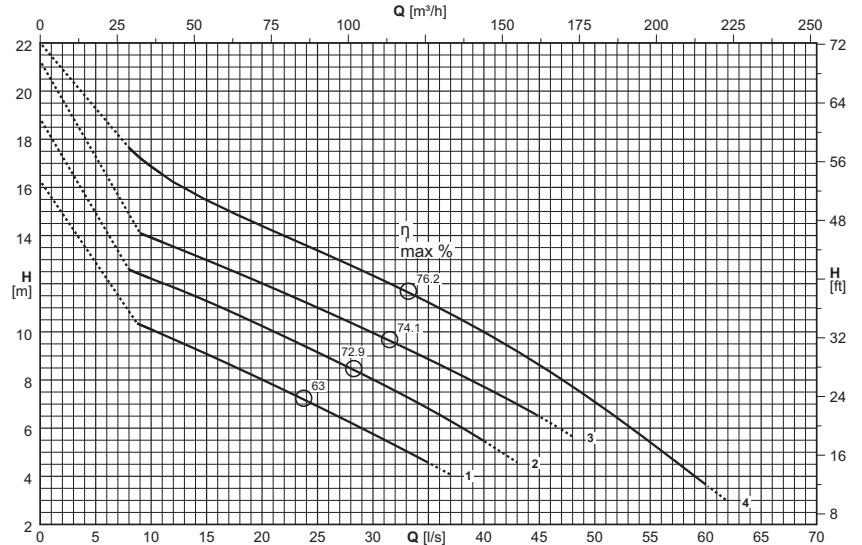

(1) = n°. of cables x (n°. of wires each cable x size [mm²]) x cable length [m] - Câble NSSHOU-J

Cable length exceeding 10 m on request

(1) = n°. câbles x (n°. conducteurs câble x section [mm²]) x longueur câble [m] - Câble NSSHOU-J

Sur demande longueur de câble supérieure à 10 m

(1) = n°. cavi x (n°. conduttori per cavo x sezione [mm²]) x lunghezza cavo [m] - Cavo NSSHOU-J

Lunghezza cavo superiore a 10 m - su richiesta

Electric pump type <i>Electropompe type</i> Elettropompa tipo	Curve <i>Courbe</i> Curva	Motor power <i>Puiss. moteur</i> Potenza motore	Capacity <i>Debit</i> Portata															
			[l/s]	0	8	10	15	20	25	30	35	40	45	50	55	60	62	
			P ₂	[m ³ /h]	0	28,8	36	54	72	90	108	126	144	162	180	198	216	223,2
			(N°)	[kW]	Head <i>Hauteur</i> Prevalenza													
			[m]	[m]	14,3		10,1	9,1	8	6,9	5,8	4,6						
KCM100HL+002941N3	1	2,9	[m]	[m]	14,3		10,1	9,1	8	6,9	5,8	4,6						
KCM100HG+003741N3	2	3,7	[m]	[m]	16,9	12,6	12,2	11,3	10,2	9,2	8	6,8	5,5					
KCM100HD+004641N3	3	4,6	[m]	[m]	19,3		13,9	13	12	11	10	8,9	7,7	6,5				
KCM100HA+005842N3	4	5,8	[m]	[m]	21,2	17,7	16,9	15,5	14,4	13,4	12,3	11,2	10	8,6	7,1	5,4	3,7	3
NPSH _R			[m]	[m]		1,1	1,1	1,5	2,1	2,9	3,9	5,1	6,4	8	9,8	11,8	14	15

P₂ = Power rated by the motor

Performance tolerance as per:

UNI/ISO 9906 Grade 3B

For motor performances specification see page "motor features"

For the accessories specification see page "Accessories"

P₂ = Puissance restituée par le moteur

Tolérances sur les performances selon normes:

UNI/ISO 9906 Niveau 3B

Pour caractéristiques techniques moteurs voir page "Caractéristiques des moteurs"

Pour les accessoires voir page "Accessories"

P₂ = Potenza resa dal motore

Tolleranze sulle prestazioni secondo norme:

UNI/ISO 9906 Grado 3B

Per caratteristiche motori vedere pagina "caratteristiche motori"

Per accessori vedere pagina accessori

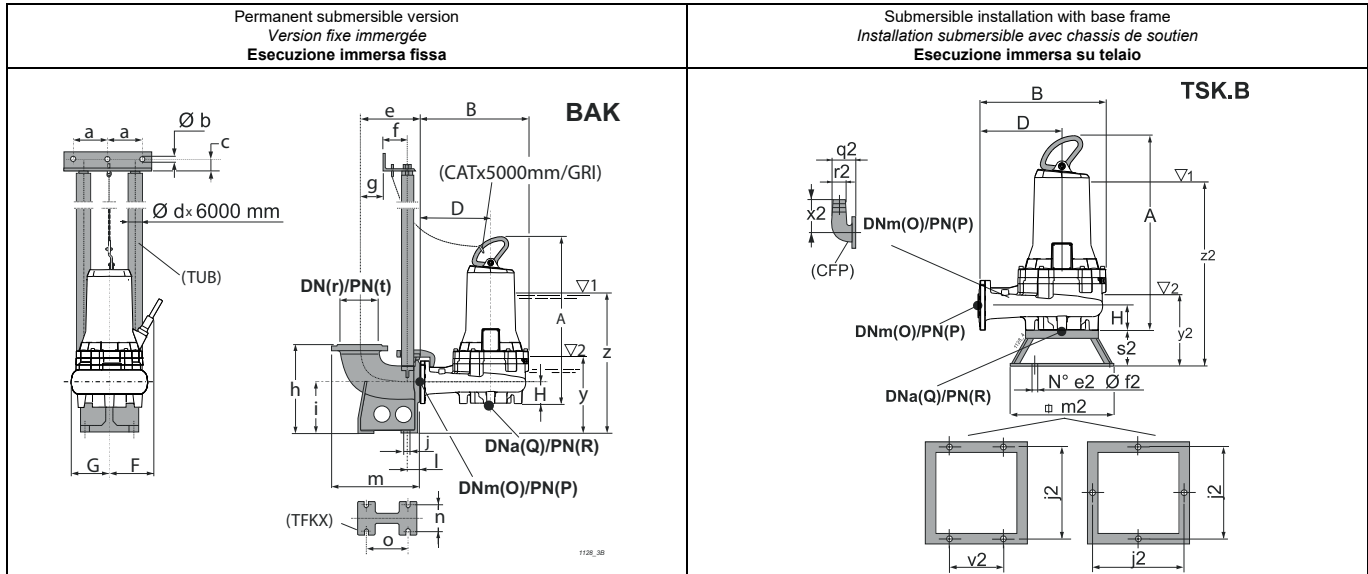

<p>For fixed installation in a dry chamber - vertical (/R) <i>Pour installation fixe en fosse sèche - verticale (/R)</i> Esecuzione per camera asciutta - verticale (/R)</p>	<p>For fixed installation in a dry chamber - horizontal (/R) <i>Pour installation fixe en fosse sèche - horizontale (/R)</i> Esecuzione per camera asciutta - orizzontale (/R)</p>
---	---

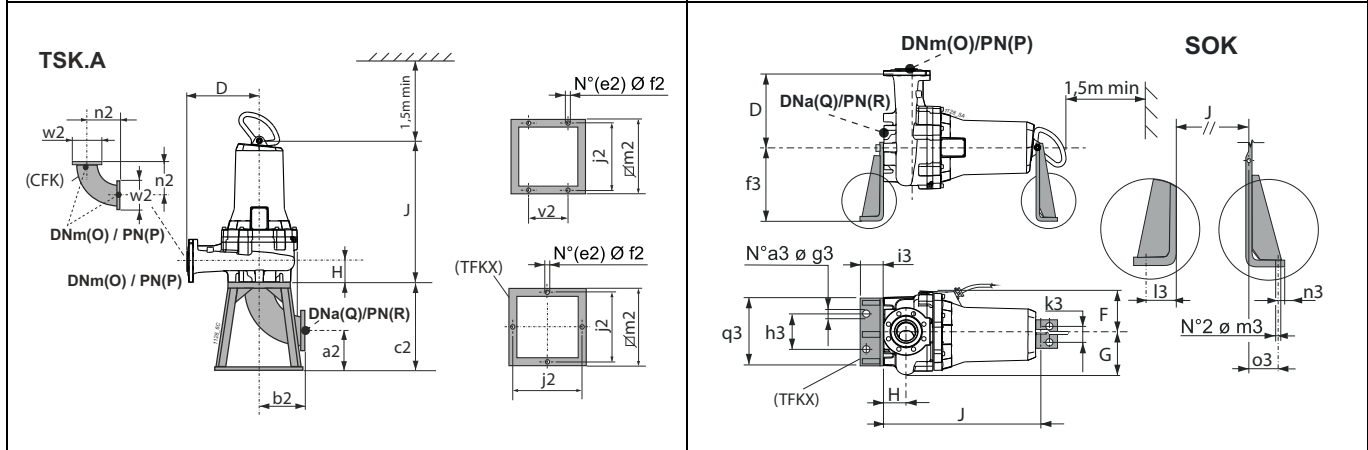

Type Type Tipo	Free passage Passage libre Passaggio Libero	Weight Poids Peso	A	B	D	F	G	H	J	O	P	Q	R	Accessories Accessoires Accessori			
			[mm]	[kg]	[mm]											BAK.	SOK.
KCM100HL+002941N3	Ø 80	103.2	650,3	435	255	204,5	198	118	565	100	16	100	16	G 2"	100/N3	100	100
KCM100HG+003741N3	Ø 80	117,6	719,4	435	255	221	198	118	601	100	16	100	16	G 2"	100/N3	100	100
KCM100HD+004641N3	Ø 80	117,6	719,4	435	255	221	198	118	601	100	16	100	16	G 2"	100/N3	100	100
KCM100HA+005842N3	Ø 80	126,6	719,4	435	255	221	198	118	601	100	16	100	16	G 2"	100/N3	100	100

BAK.	a	b	c	d	e	f	g	h	i	j	l	m	n	o	r	t	y	z
BAKG 2"	130	12,5	35	2"	228	102	48	350	200	18	49	338	135	186	100	16	282	537
SOK.	a3	f3	g3	h3	i3	k3	l3	m3	n3	o3	q3							
SOK100/N3	2	400	22	320	100	100	66	22	34	43	470							
TSK.A	a2	b2	c2	e2	f2	j2	m2	n2	v2	w2								
TSK100A	135	204	340	4	22	600	650	204	-	220								
TSK.B	e2	f2	j2	m2	q2	r2	s2	v2	x2	y2	z2							
TSK100B	4	14	600	650	215	100	180	350	273	380	635							

(3) z = Minimum submergence depth for motor without casing with continuous duty S1 (NPSHR permitting) (3) z = Immersion minimum pour moteur sans chemise en service continu S1 (compatible avec le NPSHR) (3) z = Immersion minima per motore senza mantello in funzione continuo S1 compatibilmente con l'NPSHR

y = Minimum submergence depth for motor without casing with intermittent duty S3 (NPSHR permitting) y = Immersion minimum pour moteur sans chemise en service intermittent S3 (compatible avec le NPSHR) y = Immersion minima per motore senza mantello in funzione intermittente S3 compatibilmente con l'NPSHR

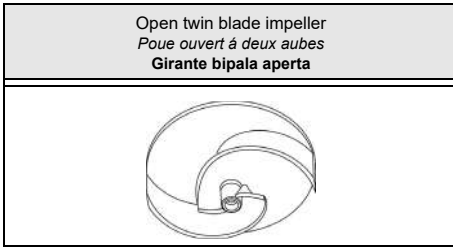

Type Type Tipo	KCA100H.+...41N3	KCA100H.+...41X3
Thermal probes Sondes thermiques Sonde termiche	Yes Oui Sì	Yes Oui Sì
Conductivity probe Sonde de conductivité Sonda di conduttività	Yes Oui Sì	Yes Oui Sì

Version cable (1) Version câble (1) Cavo Versione (1)		
Electric pump type Electropompe type Elettropompa tipo	Power supply Alimentation Alimentazione	Auxiliary Auxiliaire Ausiliario
KCA100HL+002941N3	1x(7x1,5)x10	
KCA100HG+003741N3	1x(7x1,5)x10	
KCA100HD+004641N3	1x(7x1,5)x10	
KCA100HA+005842N3	1x(10x2,5)x10	

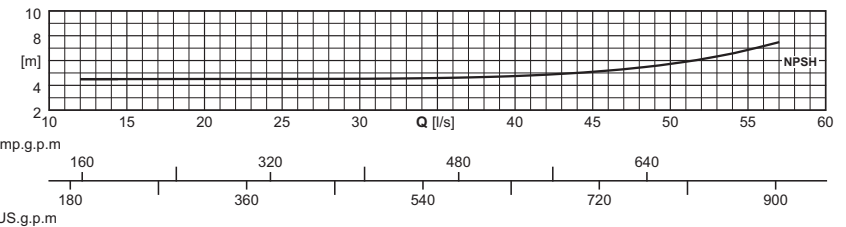
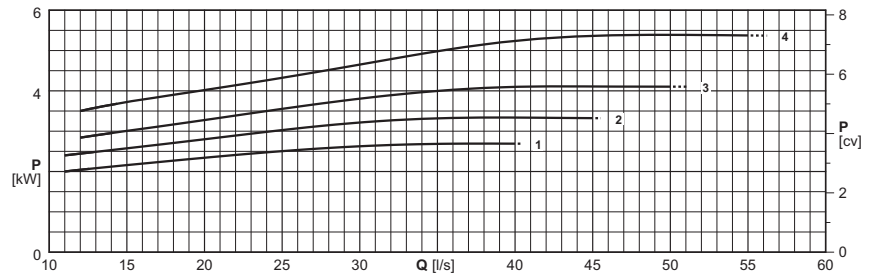
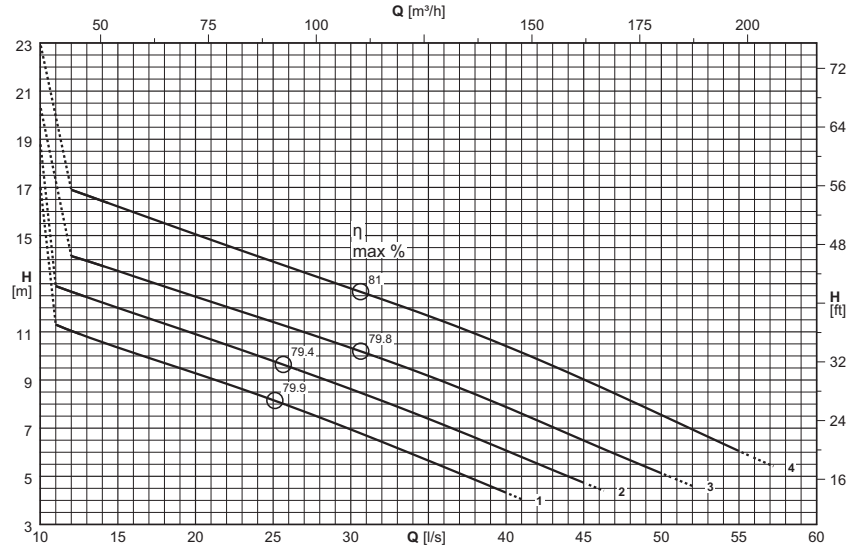

(1) = n°. of cables x (n°. of wires each cable x size [mm²]) x cable length [m] - Câble NSSHOU-J
Cable length exceeding 10 m on request

(1) = n°. câbles x (n°. conducteurs câble x section [mm²]) x longueur câble [m] - Câble NSSHOU-J
Sur demande longueur de câble supérieure à 10 m

(1) = n°. cavi x (n°. conduttori per cavo x sezione [mm²]) x lunghezza cavo [m] - Cavo NSSHOU-J
Lunghezza cavo superiore a 10 m - su richiesta

Electric pump type Electropompe type Elettropompa tipo	Curve Courbe Curva	Motor power Puiss. moteur Potenza motore	Capacity Débit Portata															
			[l/s]	0	15	20	25	30	35	40	45	50	55	57				
			P ₂	[m ³ /h]	0	54	72	90	108	126	144	162	180	198	205,2			
			(N°)	[kW]	Head Hauteur Prevalenza													
			[m]	[m]	14,1	10,4	9,3	8,2	6,9	5,7	4,3							
KCA100HL+002941N3	1	2,9	[m]	[m]	14,1	10,4	9,3	8,2	6,9	5,7	4,3							
KCA100HG+003741N3	2	3,7	[m]	[m]	15,9	12	10,9	9,8	8,6	7,4	6,1	4,7						
KCA100HD+004641N3	3	4,6	[m]	[m]	17,4	13,5	12,5	11,4	10,3	9,2	7,9	6,5	5,1					
KCA100HA+005842N3	4	5,8	[m]	[m]	20,9	16,2	15,1	13,9	12,8	11,7	10,4	9	7,5	6,1	5,5			
NPSH _R			[m]	[m]		4,5	4,5	4,5	4,5	4,6	4,8	5,1	5,7	6,9	7,5			

P₂ = Power rated by the motor
Performance tolerance as per:
UNI/ISO 9906 Grade 3B

For motor performances specification see page "motor features"

For the accessories specification see page "Accessories"
The impellers will be trimmed to meet the duty point

P₂ = Puissance restituée par le moteur
Tolérances sur les performances selon normes:
UNI/ISO 9906 Niveau 3B
Pour caractéristiques techniques moteurs voir page "Caractéristiques des moteurs"

Pour les accessoires voir page "Accessories"
Le point de fonctionnement désiré peut être obtenu par rognage de roue

P₂ = Potenza resa dal motore
Tolleranze sulle prestazioni secondo norme:
UNI/ISO 9906 Grado 3B

Per caratteristiche motori vedere pagina "caratteristiche motori"

Per accessori vedere pagina accessori
Le giranti vengono tornite in modo da ottenere il punto di lavoro richiesto

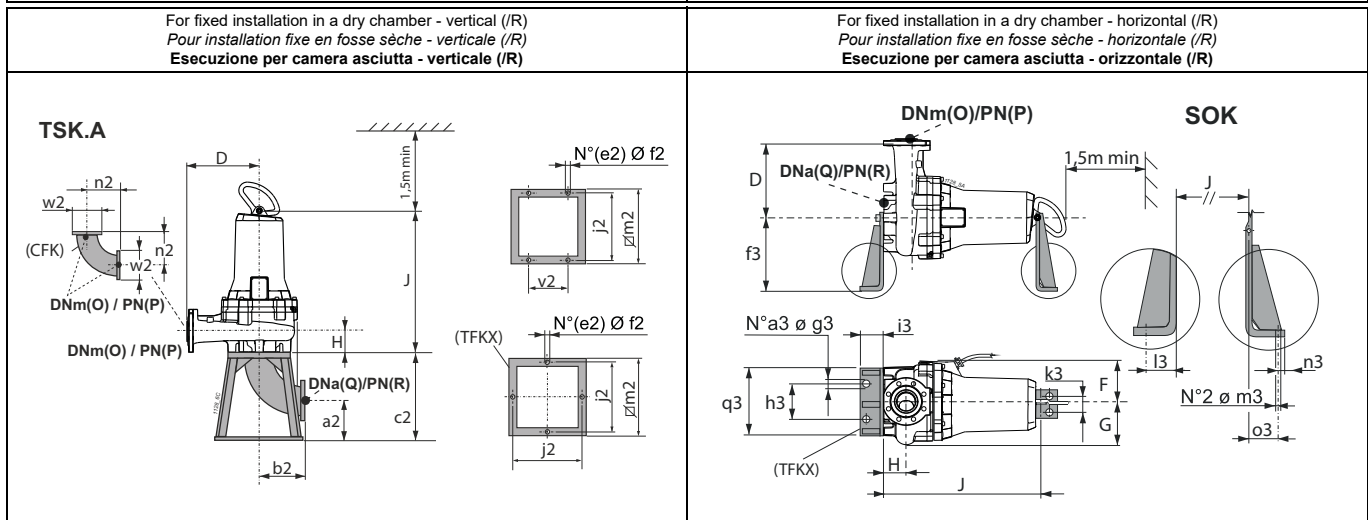
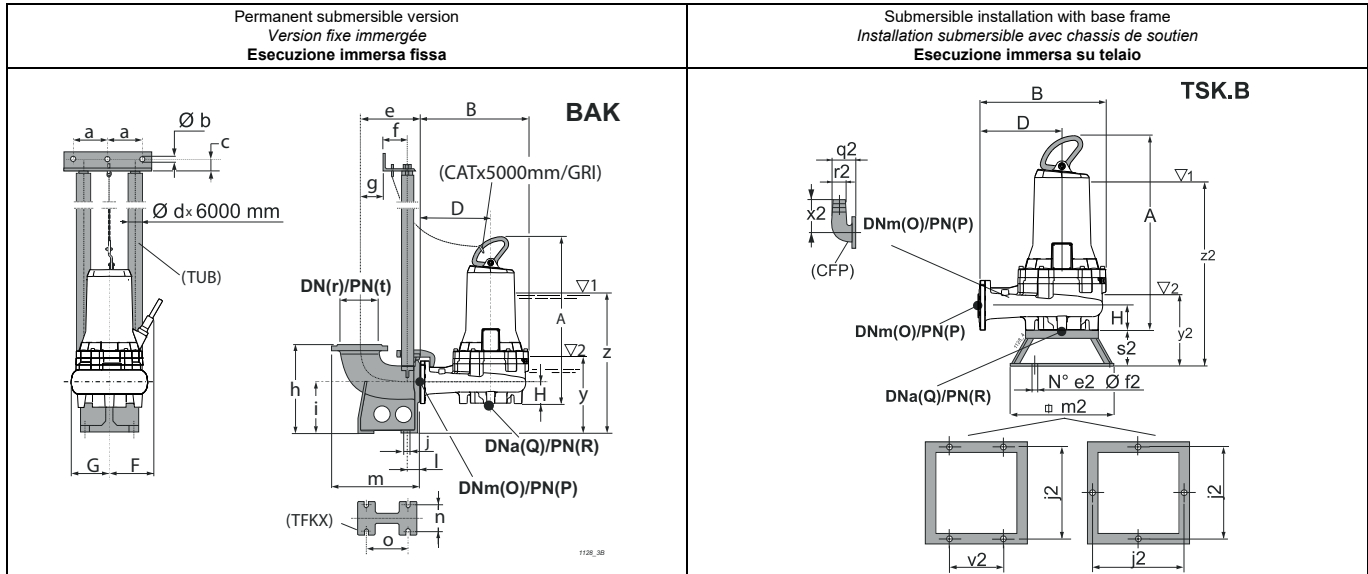

Type Type Tipo	Free passage Passage libre Passaggio Libero	Weight Poids Peso	A	B	D	F	G	H	J	O	P	Q	R	Accessories Accessoires Accessori			
	[mm]	[kg]	[mm]											BAK.	SOK.	TSK.A	TSK.B
KCA100HL+002941N3	---	103,7	635,3	492	300	204,5	213,3	116	550	100	16	100	16(*)	G 2"	100/N3	100	100
KCA100HG+003741N3	---	118,3	704,4	492	300	221	213,3	116	586	100	16	100	16(*)	G 2"	100/N3	100	100
KCA100HD+004641N3	---	118,8	704,4	492	300	221	213,3	116	586	100	16	100	16(*)	G 2"	100/N3	100	100
KCA100HA+005842N3	---	128,3	704,4	492	300	221	213,3	116	586	100	16	100	16(*)	G 2"	100/N3	100	100

BAK.	a	b	c	d	e	f	g	h	i	j	l	m	n	o	r	t	y	z
BAKG 2"	130	12,5	35	2"	228	102	48	350	200	18	49	338	135	186	100	16	269	524
SOK.	a3	f3	g3	h3	i3	k3	l3	m3	n3	o3	q3							
SOK100/N3	2	400	22	320	100	100	66	22	34	43	470							
TSK.A	a2	b2	c2	e2	f2	j2	m2	n2	v2	w2								
TSK100A	135	204	340	4	22	600	650	204	-	220								
TSK.B	e2	f2	j2	m2	q2	r2	s2	v2	x2	y2	z2							
TSK100B	4	14	600	650	215	100	180	350	273	365	620							

(3) z = Minimum submergence depth for motor without casing with continuous duty S1 (NPSHR permitting)

y = Minimum submergence depth for motor without casing with intermittent duty S3 (NPSHR permitting)

(*) Consult the flanges page.

(3) z = Immersion minimum pour moteur sans chemise en service continu S1 (compatible avec le NPSHR)

y = Immersion minimum pour moteur sans chemise en service intermittent S3 (compatible avec le NPSHR)

(*) Voir page brides.

(3) z = Immersione minima per motore senza mantello in funzione continuo S1 compatibilmente con l'NPSHR

y = Immersione minima per motore senza mantello in funzione intermittente S3 compatibilmente con l'NPSHR

(*) Vedere pagina flange.

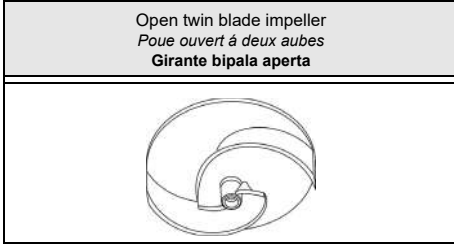

Type Type Tipo	KCA100L...42N3	KCA100L...42X3
Thermal probes Sondes thermiques Sonde termiche	Yes Oui Sì	Yes Oui Sì
Conductivity probe Sonde de conductivité Sonda di conduttività	Yes Oui Sì	Yes Oui Sì

Version cable (1)
Version câble (1)
Cavo Versione (1)

Electric pump type Electropompe type Elettropompa tipo	Power supply Alimentation Alimentazione	Auxiliary Auxiliaire Ausiliario
KCA100LL+007542N3	1x(10x2,5)x10	
KCA100LG+010542N3	1x(10x2,5)x10	
KCA100LD+012542N3	1x(10x2,5)x10	
KCA100LA+012542N3	1x(10x2,5)x10	

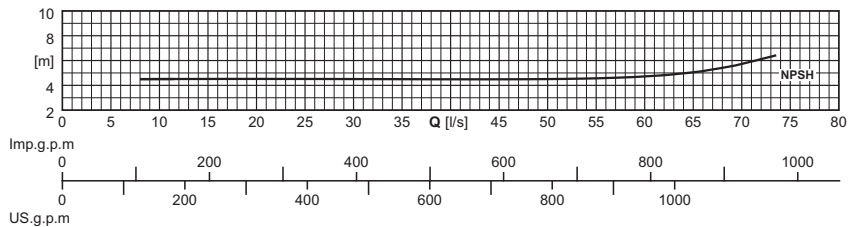
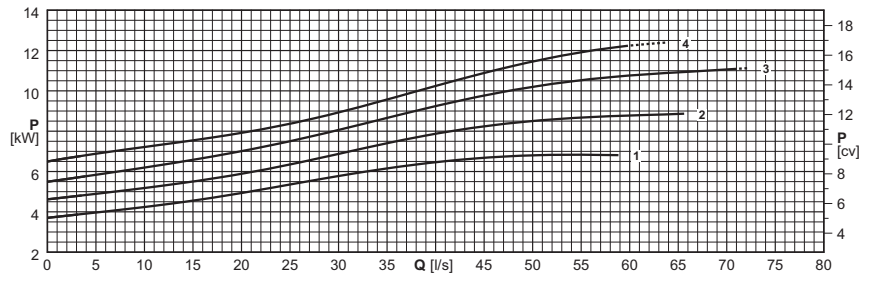
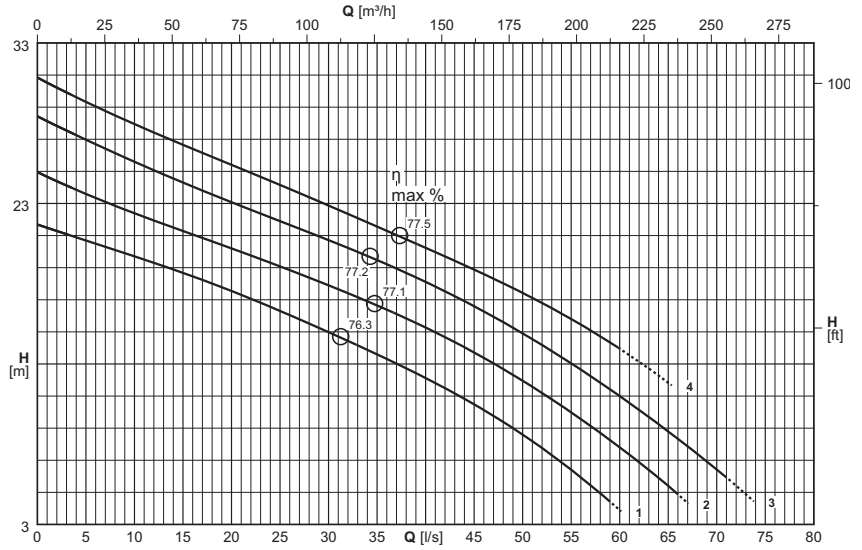

(1) = n°. of cables x (n°. of wires each cable x size [mm²]) x cable length [m] - Cable NSSHOU-J
Cable length exceeding 10 m on request

(1) = n°. câbles x (n°. conducteurs câble x section [mm²]) x longueur câble [m] - Câble NSSHOU-J
Sur demande longueur de câble supérieure à 10 m

(1) = n°. cavi x (n°. conduttori per cavo x sezione [mm²]) x lunghezza cavo [m] - Cavo NSSHOU-J
Lunghezza cavo superiore a 10 m - su richiesta

Electric pump type Electropompe type Elettropompa tipo	Curve Courbe Curva	Motor power Puiss. moteur Potenza motore	Capacity Débit Portata																	
			[l/s]	0	4	5	10	15	20	25	30	35	40	45	50	60	70	73		
			P ₂	[m³/h]	0	14,4	18	36	54	72	90	108	126	144	162	180	216	252	262,8	
			(N°)	[kW]	Head Hauteur Prevalenza															
			[m]	[m]	21,7	20,9	20,7	19,7	18,7	17,5	16,3	15	13,6	12,1	10,5	8,6	3,9			
KCA100LL+007542N3	1	7,5	[m]	[m]	21,7	20,9	20,7	19,7	18,7	17,5	16,3	15	13,6	12,1	10,5	8,6	3,9			
KCA100LG+010542N3	2	10,5	[m]	[m]	25	23,9	23,6	22,4	21,3	20,2	19,1	17,9	16,6	15,3	13,7	11,9	7,8			
KCA100LD+012542N3	3	12,5	[m]	[m]	28,4	27,3	27	25,6	24,3	23,1	21,9	20,7	19,5	18,1	16,6	14,9	11	6,4	4,9	
KCA100LA+012542N3	4	12,5	[m]	[m]	30,8	29,6	29,3	27,9	26,7	25,4	24,2	22,9	21,6	20,2	18,9	17,4	13,9			
NPSH _R			[m]	[m]				4,5	4,5	4,5	4,5	4,5	4,5	4,5	4,5	4,5	4,7	5,8	6,3	

P₂ = Power rated by the motor
Performance tolerance as per:
UNI/ISO 9906 Grade 3B

For motor performances specification see page "motor features"

For the accessories specification see page "Accessories"
The impellers will be trimmed to meet the duty point

P₂ = Puissance restituée par le moteur
Tolérances sur les performances selon normes:
UNI/ISO 9906 Niveau 3B
Pour caractéristiques techniques moteurs voir page "Caractéristiques des moteurs"

Pour les accessoires voir page "Accessories"
Le point de fonctionnement désiré peut être obtenu par rognage de roue

P₂ = Potenza resa dal motore
Tolleranze sulle prestazioni secondo norme:
UNI/ISO 9906 Grado 3B

Per caratteristiche motori vedere pagina "caratteristiche motori"

Per accessori vedere pagina accessori
Le giranti vengono tornite in modo da ottenere il punto di lavoro richiesto

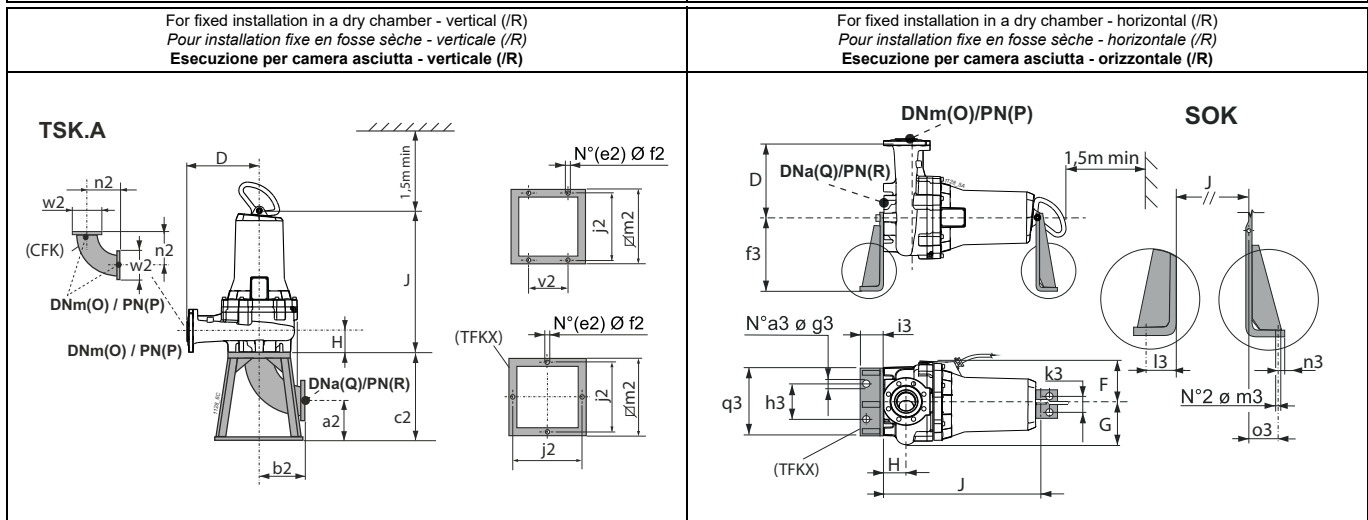
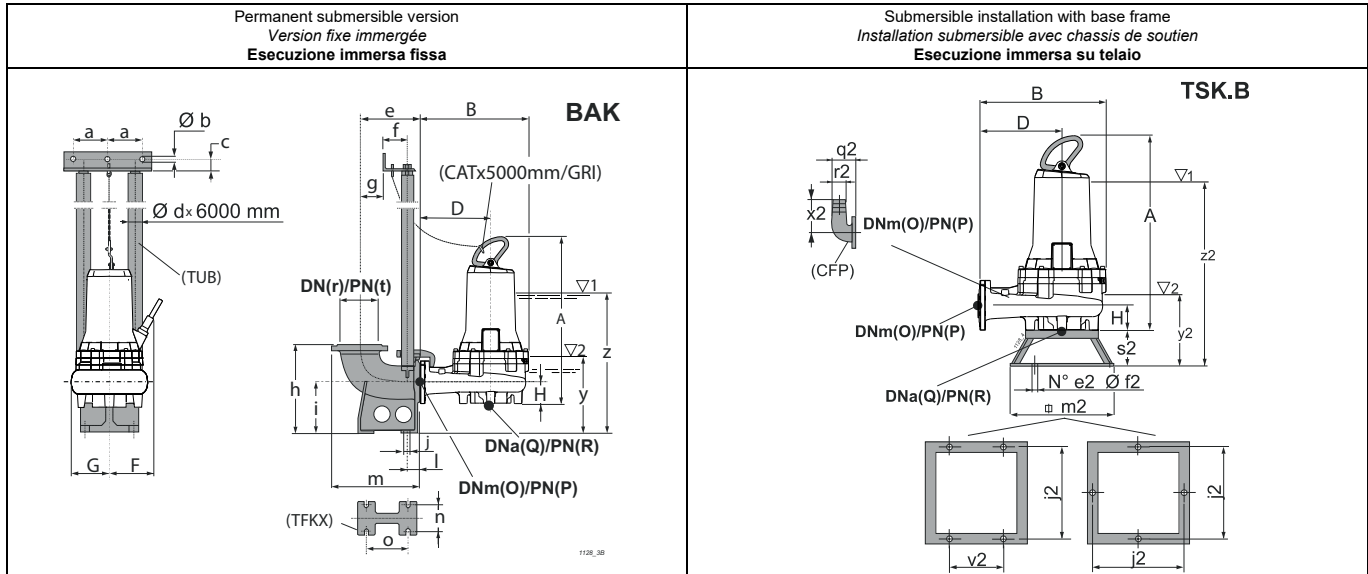

Type Type Tipo	Free passage Passage libre Passaggio Libero	Weight Poids Peso	A	B	D	F	G	H	J	O	P	Q	R	Accessories Accessoires Accessori			
			[mm]	[kg]	[mm]											BAK.	SOK.
KCA100LL+007542N3	---	161,7	763,6	530	320	236,5	228	113,2	644,2	100	16	100	16(*)	G 2"	100/N3	100	100
KCA100LG+010542N3	---	185,4	766	530	320	236,5	228	113,2	646,6	100	16	100	16(*)	G 2"	100/N3	100	100
KCA100LD+012542N3	---	185,9	766	530	320	236,5	228	113,2	646,6	100	16	100	16(*)	G 2"	100/N3	100	100
KCA100LA+012542N3	---	186,3	766	530	320	236,5	228	113,2	646,6	100	16	100	16(*)	G 2"	100/N3	100	100

BAK.		a	b	c	d	e	f	g	h	i	j	l	m	n	o	r	t	y	z
BAKG 2"		130	12,5	35	2"	228	102	48	350	200	18	49	338	135	186	100	16	269,4	620,4
SOK.		a3	f3	g3	h3	i3	k3	l3	m3	n3	o3	q3							
SOK100/N3		2	400	22	320	100	100	66	22	34	43	470							
TSK.A		a2	b2	c2	e2	f2	j2	m2	n2	v2	w2								
TSK100A		135	204	340	4	22	600	650	204	-	220								
TSK.B		e2	f2	j2	m2	q2	r2	s2	v2	x2	y2	z2							
TSK100B		4	14	600	650	215	100	180	350	273	362,6	713,6							

(3) z = Minimum submergence depth for motor without casing with continuous duty S1 (NPSHR permitting) (3) z = Immersion minimum pour moteur sans chemise en service continu S1 (compatible avec le NPSHR) (3) z = Immersion minima per motore senza mantello in funzione continuo S1 compatibilmente con l'NPSHR

y = Minimum submergence depth for motor without casing with intermittent duty S3 (NPSHR permitting) y = Immersion minimum pour moteur sans chemise en service intermittent S3 (compatible avec le NPSHR) y = Immersion minima per motore senza mantello in funzione intermittente S3 compatibilmente con l'NPSHR

(*) Consult the flanges page. (*) Voir page brides. (*) Vedere pagina flange.

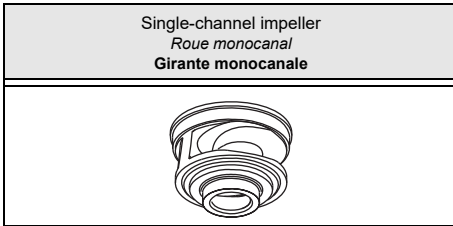

Type Type Tipo	KCM150L...+...61N3	KCM150L...+...61X3
Thermal probes <i>Sondes thermiques</i> Sonda termiche	Yes <i>Oui</i> SI	Yes <i>Oui</i> SI
Conductivity probe <i>Sonde de conductivité</i> Sonda di conduttività	Yes <i>Oui</i> SI	Yes <i>Oui</i> SI

Version cable (1)
Version câble (1)
Cavo Versione (1)

Electric pump type <i>Electropompe type</i> Elettropompa tipo	Power supply <i>Alimentation</i> Alimentazione	Auxiliary <i>Auxiliaire</i> Ausiliario
KCM150LG+004061N3	1x(7x1,5)x10	
KCM150LD+004061N3	1x(7x1,5)x10	
KCM150LA+004061N3	1x(7x1,5)x10	

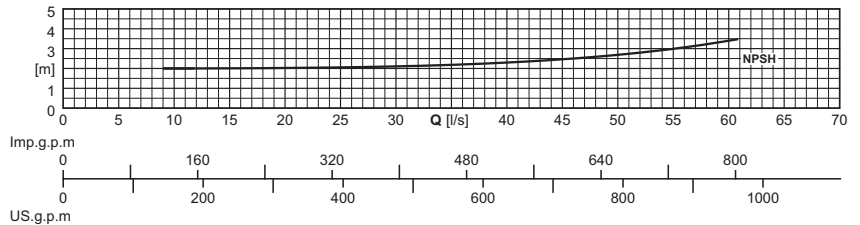
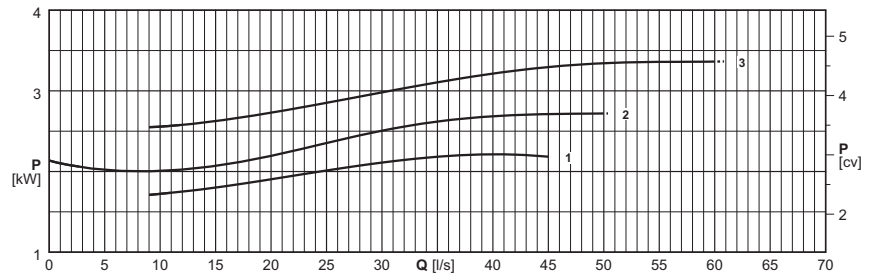
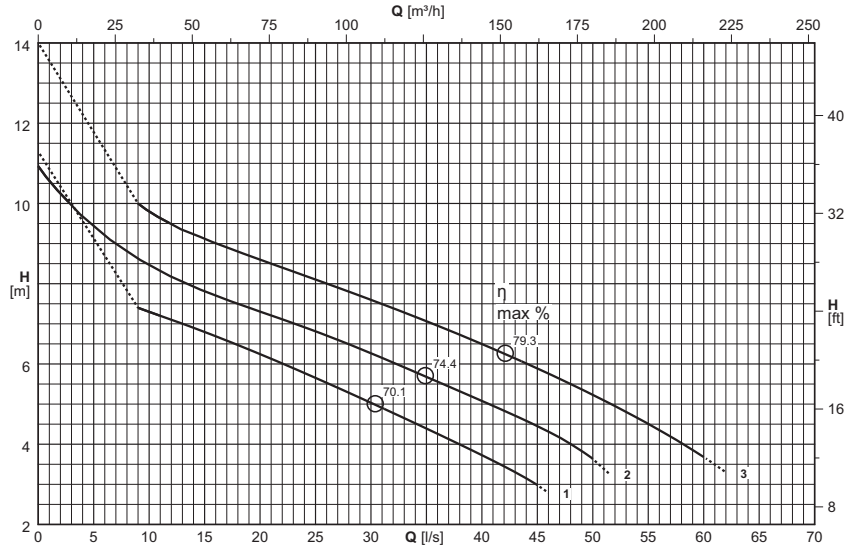

(1) = n°. of cables x (n°. of wires each cable x size [mm²]) x cable length [m] - Cable NSSHOU-J
Cable length exceeding 10 m on request

(1) = n°. câbles x (n°. conducteurs câble x section [mm²]) x longueur câble [m] - Câble NSSHOU-J
Sur demande longueur de câble supérieure à 10 m

(1) = n°. cavi x (n°. conduttori per cavo x sezione [mm²]) x lunghezza cavo [m] - Cavo NSSHOU-J
Lunghezza cavo superiore a 10 m - su richiesta

Electric pump type <i>Electropompe type</i> Elettropompa tipo	Curve <i>Courbe</i> Curva	Motor power <i>Puiss. moteur</i> Potenza motore	Capacity <i>Debit</i> Portata																		
			[l/s]	0	3	4	6	8	10	15	20	25	30	35	40	45	50	55	60	62	
		P ₂	[m³/h]	0	10,8	14,4	21,6	28,8	36	54	72	90	108	126	144	162	180	198	216	223,2	
	(N°)	[kW]	Head <i>Hauteur</i> Prevalenza																		
KCM150LG+004061N3	1	4	[m]	9,3				7,3	6,8	6,2	5,7	5	4,4	3,7	3						
KCM150LD+004061N3	2	4	[m]	10,9	10	9,7	9,2	8,8	8,5	7,8	7,3	6,8	6,3	5,7	5,1	4,4	3,6				
KCM150LA+004061N3	3	4	[m]	12,4					9,8	9,1	8,6	8,1	7,6	7,1	6,5	5,9	5,2	4,5	3,7	3,3	
NPSH _R			[m]					2	2	2	2,1	2,1	2,2	2,3	2,5	2,7	3	3,4	3,6		

P₂ = Power rated by the motor

Performance tolerance as per: UNI/ISO 9906 Grade 3B

For motor performances specification see page "motor features"

For the accessories specification see page "Accessories"

P₂ = Puissance restituée par le moteur

Tolérances sur les performances selon normes: UNI/ISO 9906 Niveau 3B

Pour caractéristiques techniques moteurs voir page "Caractéristiques des moteurs"

Pour les accessoires voir page "Accessories"

P₂ = Potenza resa dal motore

Tolleranze sulle prestazioni secondo norme: UNI/ISO 9906 Grado 3B

Per caratteristiche motori vedere pagina "caratteristiche motori"

Per accessori vedere pagina accessori

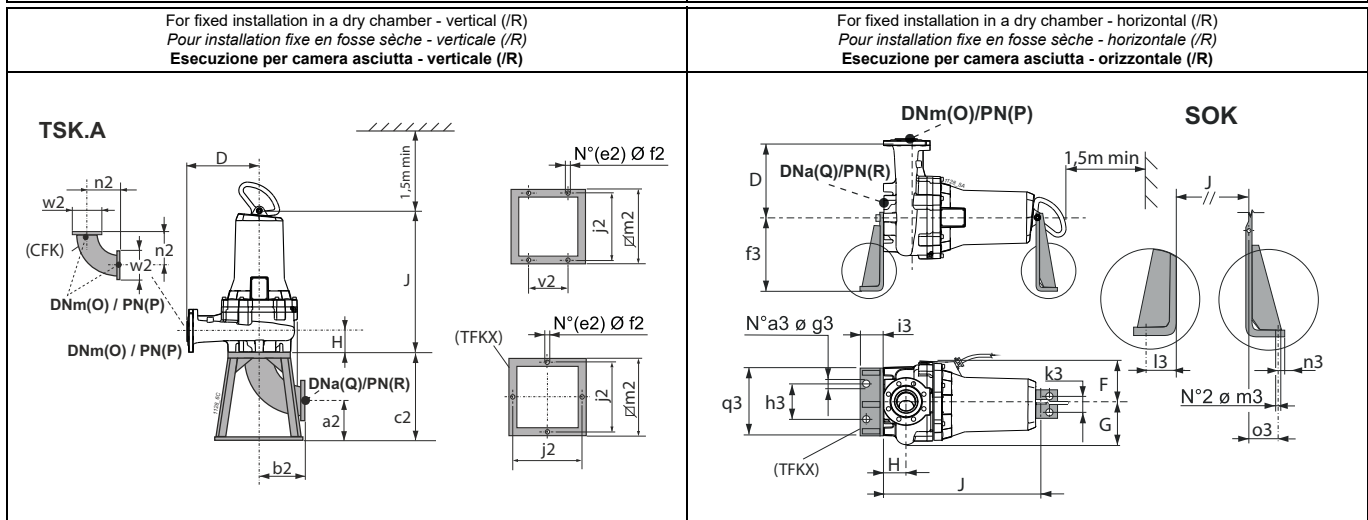
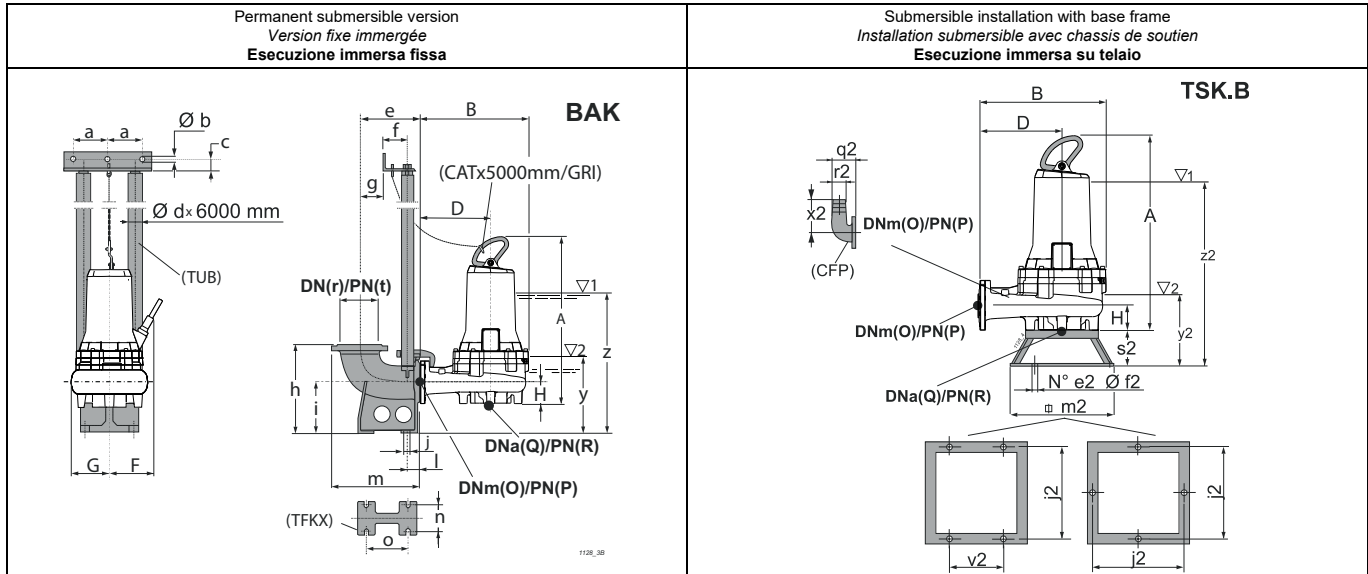

Type Type Tipo	Free passage Passage libre Passaggio Libero	Weight Poids Peso	A	B	D	F	G	H	J	O	P	Q	R	Accessories Accessoires Accessori				
	[mm]		[kg]	[mm]											BAK.	SOK.	TSK.A	TSK.B
KCM150LG+004061N3	Ø 100	168,5	808	532	305	227	241	138	688,6	150	16	150	16	VI 2"	150/N3	I	M	
KCM150LD+004061N3	Ø 100	168	808	532	305	227	241	138	688,6	150	16	150	16	VI 2"	150/N3	I	M	
KCM150LA+004061N3	Ø 100	167,8	808	532	305	227	241	138	688,6	150	16	150	16	VI 2"	150/N3	I	M	
BAK.	a	b	c	d	e	f	g	h	i	j	l	m	n	o	r	t	y	z
BAKVI 2"	158	12,5	35	2"	260	102	75	435	235	19	59	403	194	214	150	16	324	675
SOK.	a3	f3	g3	h3	i3	k3	l3	m3	n3	o3	q3							
SOK150/N3	2	400	22	320	100	100	66	22	34	43	470							
TSK.A	a2	b2	c2	e2	f2	j2	m2	n2	v2	w2								
TSKIA	205	395	600	4	22	600	650	395	-	285								
TSK.B	e2	f2	j2	m2	q2	r2	s2	v2	x2	y2	z2							
TSKMB	4	14	600	650	315	150	220	350	380	447	798							

(3) z = Minimum submergence depth for motor without casing with continuous duty S1 (NPSHR permitting)

y = Minimum submergence depth for motor without casing with intermittent duty S3 (NPSHR permitting)

(3) z = Immersion minimum pour moteur sans chemise en service continu S1 (compatible avec le NPSHR)

y = Immersion minimum pour moteur sans chemise en service intermittent S3 (compatible avec le NPSHR)

(3) z = Immersion minima per motore senza mantello in funzione continuo S1 compatibilmente con l'NPSHR

y = Immersion minima con motore senza mantello in funzione intermittente S3 compatibilmente con l'NPSHR

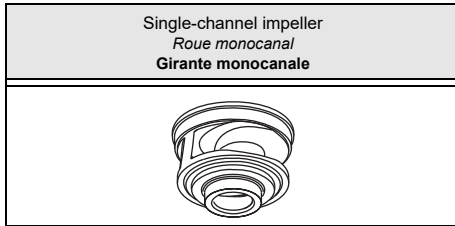

Type Type Tipo	KCM150H...41N3	KCM150H...41X3
Thermal probes <i>Sondes thermiques</i> Sonda termiche	Yes <i>Oui</i> SI	Yes <i>Oui</i> SI
Conductivity probe <i>Sonde de conductivité</i> Sonda di conduttività	Yes <i>Oui</i> SI	Yes <i>Oui</i> SI

Version cable (1)
Version câble (1)
Cavo Versione (1)

Electric pump type <i>Electropompe type</i> Elettropompa tipo	Power supply <i>Alimentation</i> Alimentazione	Auxiliary <i>Auxiliaire</i> Ausiliario
KCM150HD+004641N3	1x(7x1,5)x10	
KCM150HA+005842N3	1x(10x2,5)x10	

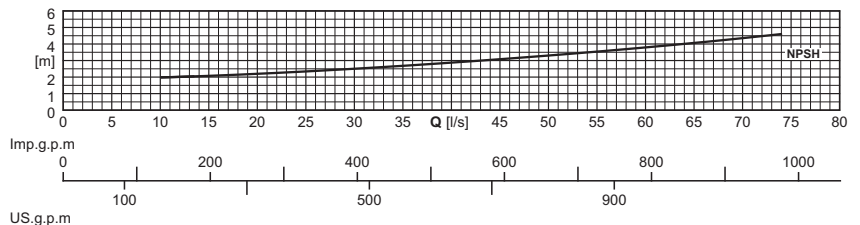
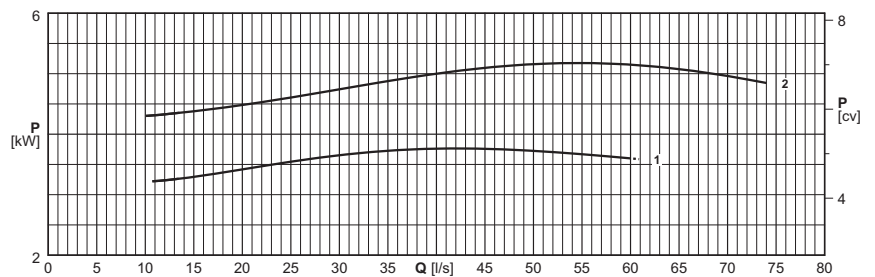
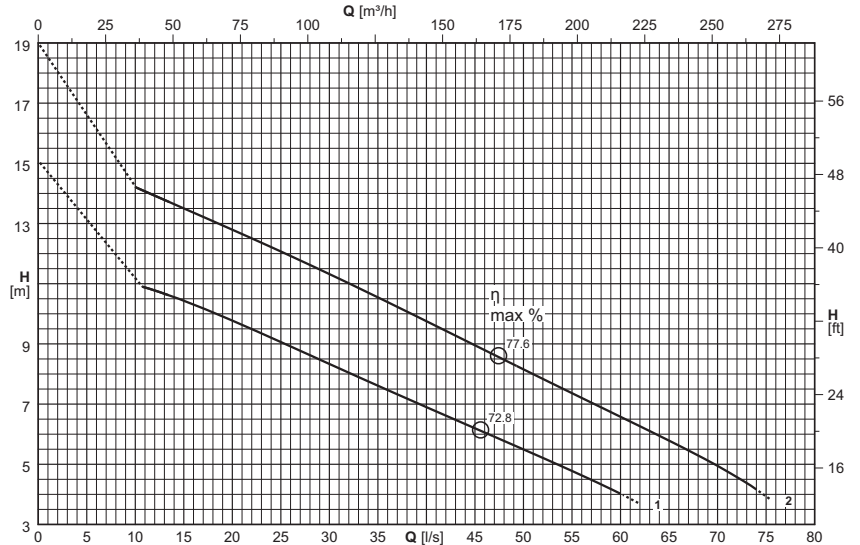

(1) = n°. of cables x (n°. of wires each cable x size [mm²]) x cable length [m] - Cable NSSHOU-J

Cable length exceeding 10 m on request

(1) = n°. câbles x (n°. conducteurs câble x section [mm²]) x longueur câble [m] - Câble NSSHOU-J

Sur demande longueur de câble supérieure à 10 m

(1) = n°. cavi x (n°. conduttori per cavo x sezione [mm²]) x lunghezza cavo [m] - Cavo NSSHOU-J

Lunghezza cavo superiore a 10 m - su richiesta

Electric pump type <i>Electropompe type</i> Elettropompa tipo	Curve <i>Courbe</i> Curva	Motor power <i>Puiss. moteur</i> Potenza motore	Capacity <i>Debit</i> Portata															
			[l/s]	0	15	20	25	30	35	40	45	50	55	60	65	70	75	
		P ₂	[m³/h]	0	54	72	90	108	126	144	162	180	198	216	234	252	270	
	(N°)	[kW]	Head <i>Hauteur</i> Prevalenza															
KCM150HD+004641N3	1	4,6	[m]	12,1	10,4	9,8	9,1	8,3	7,6	6,9	6,2	5,5	4,8	4				
KCM150HA+005842N3	2	5,8	[m]	18,1	13,5	12,8	12,1	11,3	10,5	9,8	9	8,2	7,4	6,6	5,8	4,9	3,9	
NPSH _R			[m]		2,1	2,2	2,3	2,5	2,7	2,9	3,1	3,3	3,5	3,8	4,1	4,4	4,7	

P₂ = Power rated by the motor

Performance tolerance as per:
UNI/ISO 9906 Grade 3B

For motor performances specification see page "motor features"

For the accessories specification see page "Accessories"

P₂ = Puissance restituée par le moteur

Tolérances sur les performances selon normes:
UNI/ISO 9906 Niveau 3B

Pour caractéristiques techniques moteurs voir page "Caractéristiques des moteurs"

Pour les accessoires voir page "Accessories"

P₂ = Potenza resa dal motore

Tolleranze sulle prestazioni secondo norme:
UNI/ISO 9906 Grado 3B

Per caratteristiche motori vedere pagina "caratteristiche motori"

Per accessori vedere pagina accessori

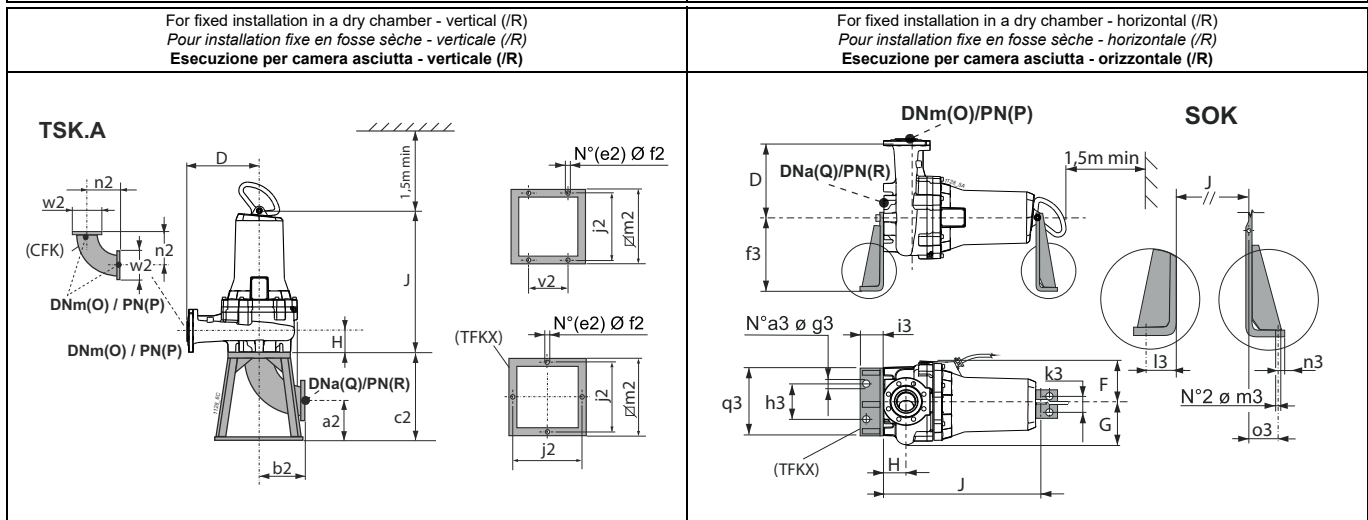
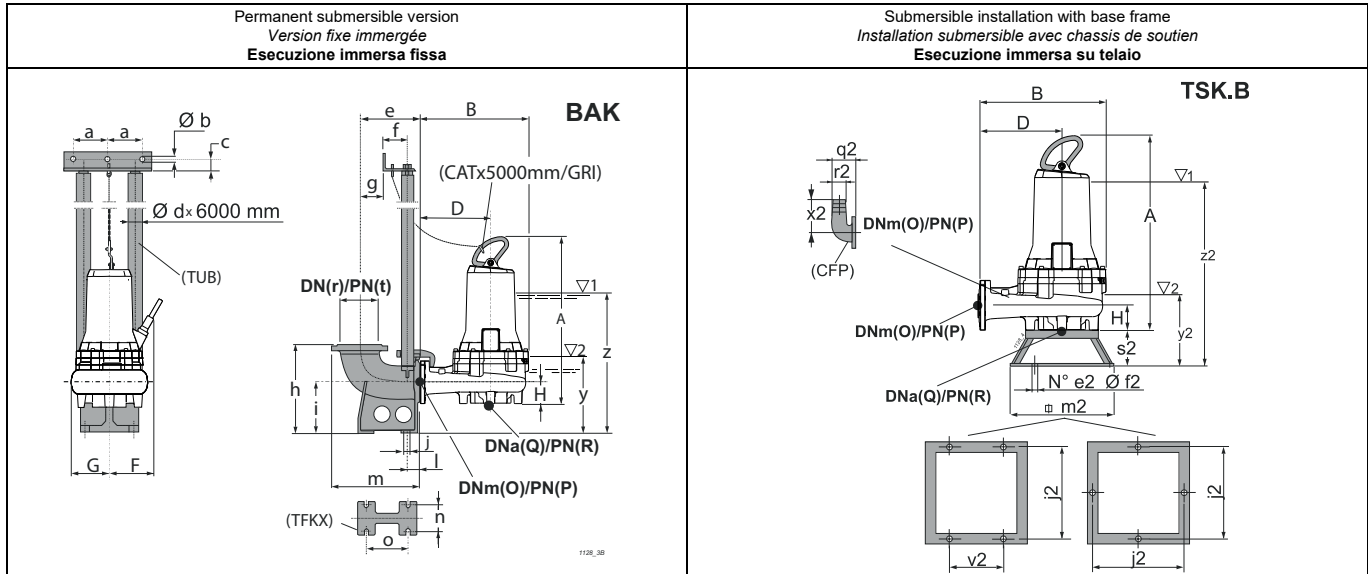

Type Type Tipo	Free passage Passage libre Passaggio Libero	Weight Poids Peso	A	B	D	F	G	H	J	O	P	Q	R	Accessories Accessoires Accessori				
	[mm]	[kg]	[mm]											BAK.	SOK.	TSK.A	TSK.B	
KCM150HD+004641N3	Ø 80	155	752,9	567	340	227	238,5	138	634,5	150	16	150	16	VI 2"	150/N3	I	M	
KCM150HA+005842N3	Ø 80	164,4	752,9	567	340	227	238,5	138	634,5	150	16	150	16	VI 2"	150/N3	I	M	
BAK.	a	b	c	d	e	f	g	h	i	j	l	m	n	o	r	t	y	z
BAKVI 2"	158	12,5	35	2"	260	102	75	435	235	19	59	403	194	214	150	16	330	585
SOK.	a3	f3	g3	h3	i3	k3	l3	m3	n3	o3	q3							
SOK150/N3	2	400	22	320	100	100	66	22	34	43	470							
TSK.A	a2	b2	c2	e2	f2	j2	m2	n2	v2	w2								
TSKIA	205	395	600	4	22	600	650	395	-	285								
TSK.B	e2	f2	j2	m2	q2	r2	s2	v2	x2	y2	z2							
TSKMB	4	14	600	650	315	150	220	350	380	453	708							

(3) z = Minimum submergence depth for motor without casing with continuous duty S1 (NPSHR permitting)

(3) z = Immersion minimum pour moteur sans chemise en service continu S1 (compatible avec le NPSHR)

(3) z = Immersion minima per motore senza mantello in funzione continuo S1 compatibilmente con l'NPSHR

y = Minimum submergence depth for motor without casing with intermittent duty S3 (NPSHR permitting)

y = Immersion minimum pour moteur sans chemise en service intermittent S3 (compatible avec le NPSHR)

y = Immersion minima con motore senza mantello in funzione intermittente S3 compatibilmente con l'NPSHR

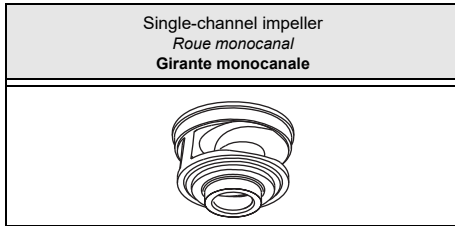

Type Type Tipo	KCM150L...+...42N3	KCM150L...+...42X3
Thermal probes Sondes thermiques Sonda termiche	Yes Oui Sì	Yes Oui Sì
Conductivity probe Sonde de conductivité Sonda di conduttività	Yes Oui Sì	Yes Oui Sì

Version cable (1) Version câble (1) Cavo Versione (1)		
Electric pump type Electropompe type Elettropompa tipo	Power supply Alimentation Alimentazione	Auxiliary Auxiliaire Ausiliario
KCM150LG+007542N3/P	1x(10x2,5)x10	
KCM150LG+007542N3/D	1x(10x2,5)x10	
KCM150LD+010542N3/P	1x(10x2,5)x10	
KCM150LD+010542N3/D	1x(10x2,5)x10	
KCM150LA+012542N3/P	1x(10x2,5)x10	
KCM150LA+012542N3/D	1x(10x2,5)x10	

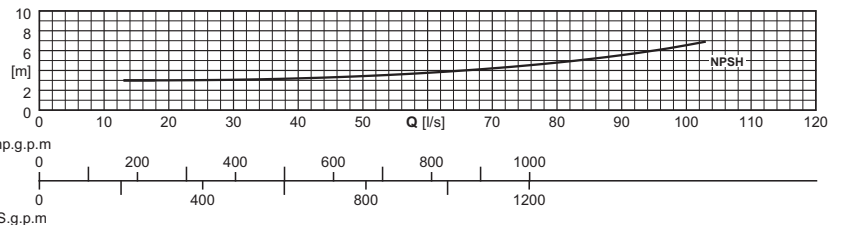
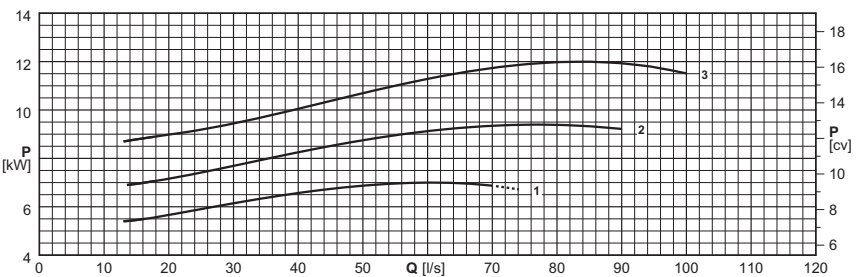
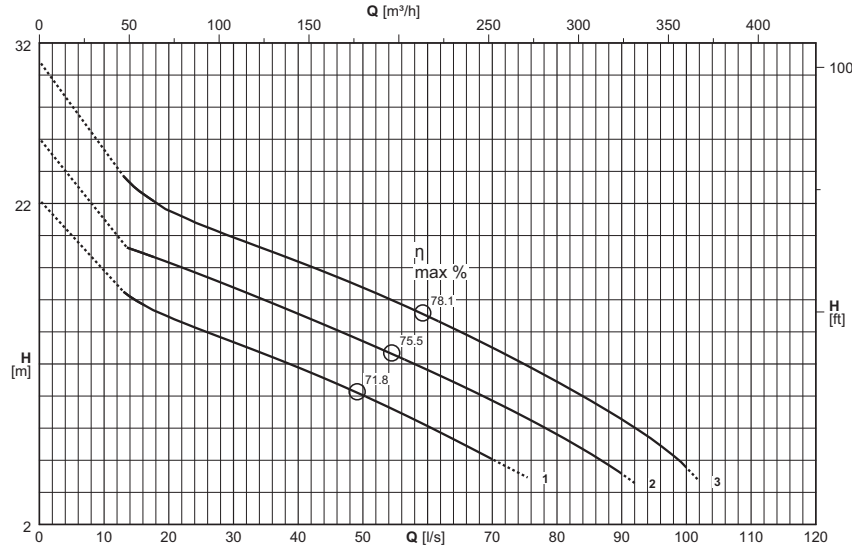

(1) = n°. of cables x (n°. of wires each cable x size [mm²]) x cable length [m] - Câble NSSHOU-J

Cable length exceeding 10 m on request

(1) = n°. câbles x (n°. conducteurs câble x section [mm²]) x longueur câble [m] - Câble NSSHOU-J

Sur demande longueur de câble supérieure à 10 m

(1) = n°. cavi x (n°. conduttori per cavo x sezione [mm²]) x lunghezza cavo [m] - Cavo NSSHOU-J

Lunghezza cavo superiore a 10 m - su richiesta

Electric pump type Electropompe type Elettropompa tipo	Curve Courbe Curva	Motor power Puiss. moteur Potenza motore	Capacity Débit Portata																	
			[l/s]	0	15	20	25	30	35	40	45	50	60	70	80	90	100	102		
			P ₂	[m ³ /h]	0	54	72	90	108	126	144	162	180	216	252	288	324	360	367,2	
			(N°)	[kW]	Head Hauteur Prevalenza															
			[m]	[m]	20,2	16	14,9	14,1	13,4	12,6	11,8	10,9	10	8,1	6,1					
KCM150LG+007542N3/P	1	7,5	[m]	[m]	20,2	16	14,9	14,1	13,4	12,6	11,8	10,9	10	8,1	6,1					
KCM150LG+007542N3/D	1	7,5	[m]	[m]	20,2	16	14,9	14,1	13,4	12,6	11,8	10,9	10	8,1	6,1					
KCM150LD+010542N3/P	2	10,5	[m]	[m]	24,1	19	18,3	17,6	16,8	16	15,1	14,3	13,4	11,6	9,7	7,6	5,1			
KCM150LD+010542N3/D	2	10,5	[m]	[m]	24,1	19	18,3	17,6	16,8	16	15,1	14,3	13,4	11,6	9,7	7,6	5,1			
KCM150LA+012542N3/P	3	12,5	[m]	[m]	28,9	23	21,6	20,7	19,9	19,1	18,4	17,6	16,8	15	13	10,9	8,5	5,5	4,7	
KCM150LA+012542N3/D	3	12,5	[m]	[m]	28,9	23	21,6	20,7	19,9	19,1	18,4	17,6	16,8	15	13	10,9	8,5	5,5	4,7	
NPSH _R			[m]	[m]		3	3	3	3,1	3,1	3,2	3,3	3,4	3,8	4,2	4,8	5,5	6,5	6,8	

P₂ = Power rated by the motor

Performance tolerance as per:
UNI/ISO 9906 Grade 3B

For motor performances specification see page "motor features"

For the accessories specification see page "Accessories"

P₂ = Puissance restituée par le moteur

Tolérances sur les performances selon normes:
UNI/ISO 9906 Niveau 3B

Pour caractéristiques techniques moteurs voir page "Caractéristiques des moteurs"

Pour les accessoires voir page "Accessories"

P₂ = Potenza resa dal motore

Tolleranze sulle prestazioni secondo norme:
UNI/ISO 9906 Grado 3B

Per caratteristiche motori vedere pagina "caratteristiche motori"

Per accessori vedere pagina accessori

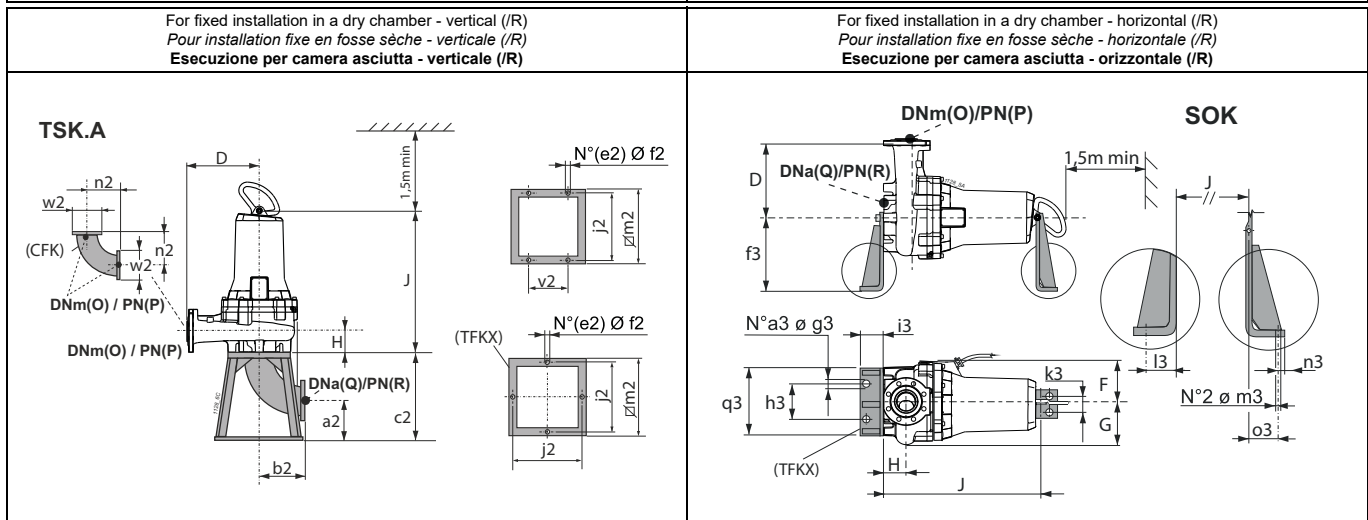
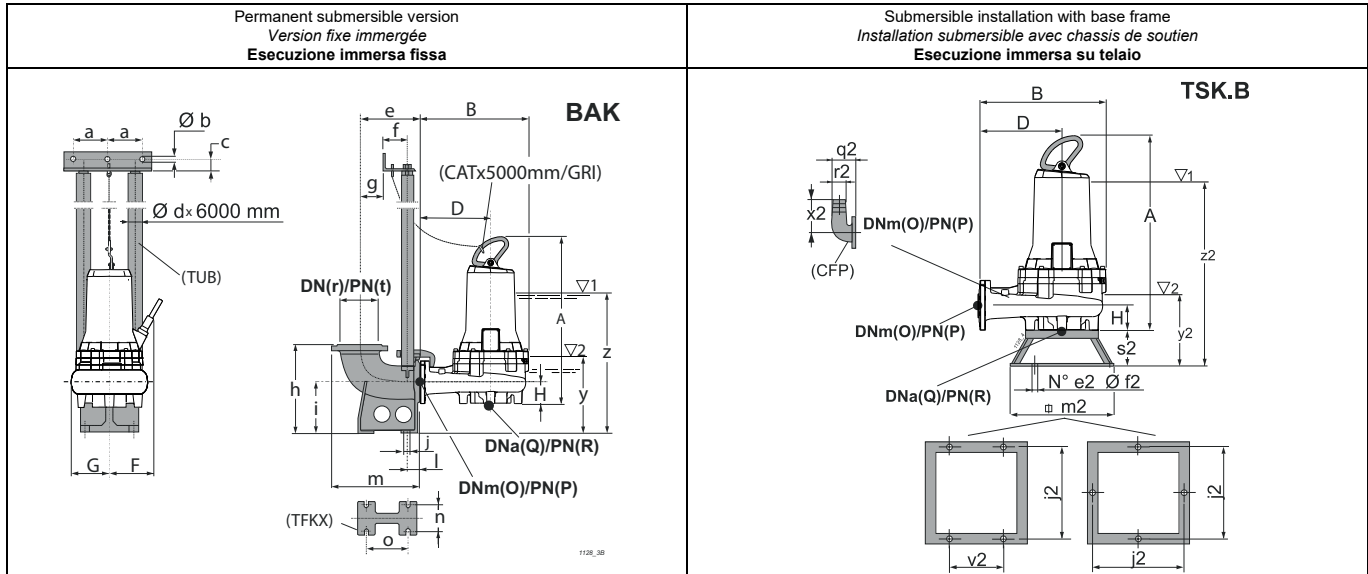

Type Type Tipo	Free passage Passage libre Passaggio Libero	Weight Poids Peso	A	B	D	F	G	H	J	O	P	Q	R	Accessories Accessoires Accessori				
			[mm]	[kg]	[mm]											BAK.	SOK.	TSK.A
KCM150LG+007542N3/P	Ø 100	177	808	532	305	227	241	138	688,6	150	16	150	16	-	150/N3	I	M	
KCM150LG+007542N3/D	Ø 100	181	808	722	495	227	241	138	-	150	16	-	-	VI 2"	-	-	-	
KCM150LD+010542N3/P	Ø 100	199,75	810,4	532	305	236	241	138	691	150	16	150	16	-	150/N3	I	M	
KCM150LD+010542N3/D	Ø 100	203,75	810,4	722	495	236	241	138	-	150	16	-	-	VI 2"	-	-	-	
KCM150LA+012542N3/P	Ø 100	199,55	810,4	532	305	236,5	241	138	691	150	16	150	16	-	150/N3	I	M	
KCM150LA+012542N3/D	Ø 100	203,55	810,4	722	495	236,5	241	138	-	150	16	-	-	VI 2"	-	-	-	
BAK.	a	b	c	d	e	f	g	h	i	j	l	m	n	o	r	t	y	z
BAKVI 2"	158	12,5	35	2"	260	102	75	435	235	19	59	403	194	214	150	16	324	675
SOK.	a3	f3	g3	h3	i3	k3	l3	m3	n3	o3	q3							
SOK150/N3	2	400	22	320	100	100	66	22	34	43	470							
TSK.A	a2	b2	c2	e2	f2	j2	m2	n2	v2	w2								
TSKIA	205	395	600	4	22	600	650	395	-	285								
TSK.B	e2	f2	j2	m2	q2	r2	s2	v2	x2	y2	z2							
TSKM B	4	14	600	650	315	150	220	350	380	447	798							

KCM150L.../P Pumps for installations on TSK

KCM150L.../D Pumps for installations on BAK

(3) z = Minimum submergence depth for motor without casing with continuous duty S1 (NPSHR permitting)

y = Minimum submergence depth for motor without casing with intermittent duty S3 (NPSHR permitting)

KCM150L.../P Pompes pour installations sur TSK

KCM150L.../D Pompes pour installations sur BAK

(3) z = Immersion minimum pour moteur sans chemise en service continu S1 (compatible avec le NPSHR)

y = Immersion minimum pour moteur sans chemise en service intermittent S3 (compatible avec le NPSHR)

KCM150L.../P Macchine per installazioni su TSK

KCM150L.../D Macchine per installazioni su BAK

(3) z = Immersione minima per motore senza mantello in funzione continuo S1 compatibilmente con l'NPSHR

y = Immersione minima con motore senza mantello in funzione intermittente S3 compatibilmente con l'NPSHR

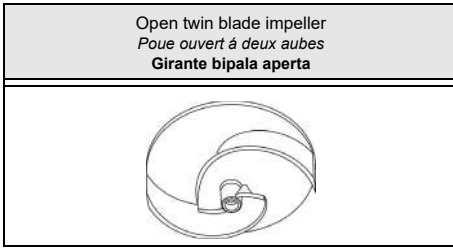

Type Type Tipo	KCA150H.+...41N3	KCA150H.+...41X3
Thermal probes Sondes thermiques Sonde termiche	Yes Oui Sì	Yes Oui Sì
Conductivity probe Sonde de conductivité Sonda di conduttività	Yes Oui Sì	Yes Oui Sì

Version cable (1)
Version câble (1)
Cavo Versione (1)

Electric pump type Electropompe type Elettropompa tipo	Power supply Alimentation Alimentazione	Auxiliary Auxiliaire Ausiliario
KCA150HP+002141N3	1x(7x1,5)x10	
KCA150HL+002941N3	1x(7x1,5)x10	
KCA150HG+003741N3	1x(7x1,5)x10	
KCA150HD+004641N3	1x(7x1,5)x10	
KCA150HA+005842N3	1x(10x2,5)x10	

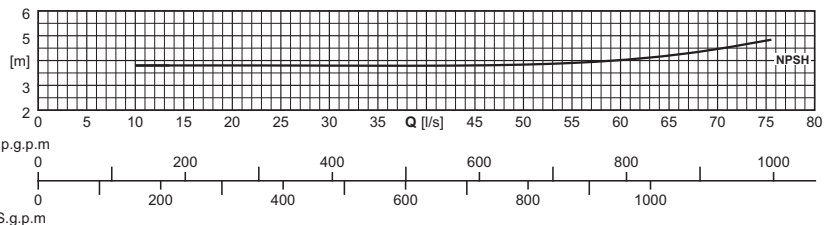
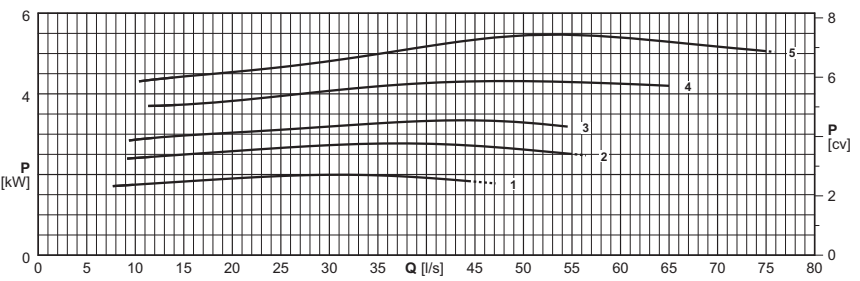
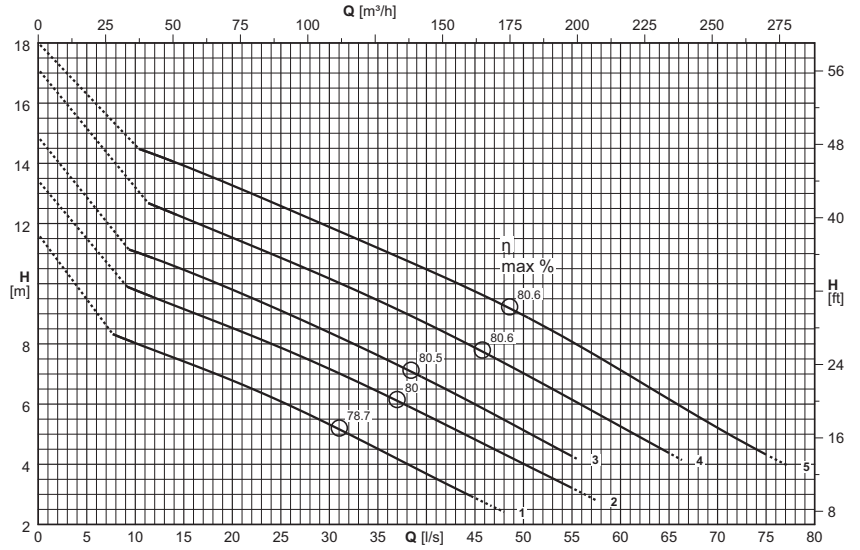

(1) = n°. of cables x (n°. of wires each cable x size [mm²]) x cable length [m] - Câble NSSHOU-J

Cable length exceeding 10 m on request

(1) = n°. câbles x (n°. conducteurs câble x section [mm²]) x longueur câble [m] - Câble NSSHOU-J

Sur demande longueur de câble supérieure à 10 m

(1) = n°. cavi x (n°. conduttori per cavo x sezione [mm²]) x lunghezza cavo [m] - Cavo NSSHOU-J

Lunghezza cavo superiore a 10 m - su richiesta

Electric pump type Electropompe type Elettropompa tipo	Curve Courbe Curva	Motor power Puiss. moteur Potenza motore	Capacity Débit Portata															
			[l/s]	0	8	10	15	20	25	30	35	40	45	50	60	70	77	
		P ₂	[m ³ /h]	0	28,8	36	54	72	90	108	126	144	162	180	216	252	277,2	
	(N°)	[kW]	Head Hauteur Prevalenza															
			[m]	9,6	8,3	8	7,4	6,8	6,1	5,3	4,5	3,7	2,9					
KCA150HP+002141N3	1	2,1	[m]	11,4		9,8	9,2	8,5	7,9	7,2	6,4	5,6	4,8	4				
KCA150HL+002941N3	2	2,9	[m]	12,9		11,1	10,5	9,8	9,1	8,4	7,6	6,8	6	5,1				
KCA150HG+003741N3	3	3,7	[m]	15,1			12,2	11,5	10,9	10,2	9,4	8,7	7,9	7	5,3			
KCA150HD+004641N3	4	4,6	[m]	16,8			13,9	13,3	12,6	11,9	11,2	10,5	9,7	8,9	7,1	5,2	4	
KCA150HA+005842N3	5	5,8	[m]															
NPSH _R			[m]			3,8	3,8	3,8	3,8	3,8	3,8	3,8	3,8	3,8	4	4,5	5	

P₂ = Power rated by the motor

Performance tolerance as per:
UNI/ISO 9906 Grade 3B

For motor performances specification see page "motor features"

For the accessories specification see page "Accessories"

The impellers will be trimmed to meet the duty point

P₂ = Puissance restituée par le moteur

Tolérances sur les performances selon normes:
UNI/ISO 9906 Niveau 3B

Pour caractéristiques techniques moteurs voir page "Caractéristiques techniques des moteurs"

Pour les accessoires voir page "Accessories"

Le point de fonctionnement désiré peut être obtenu par rognage de roue

P₂ = Potenza resa dal motore

Tolleranze sulle prestazioni secondo norme:
UNI/ISO 9906 Grado 3B

Per caratteristiche motori vedere pagina "caratteristiche motori"

Per accessori vedere pagina accessori

Le giranti vengono tornite in modo da ottenere il punto di lavoro richiesto

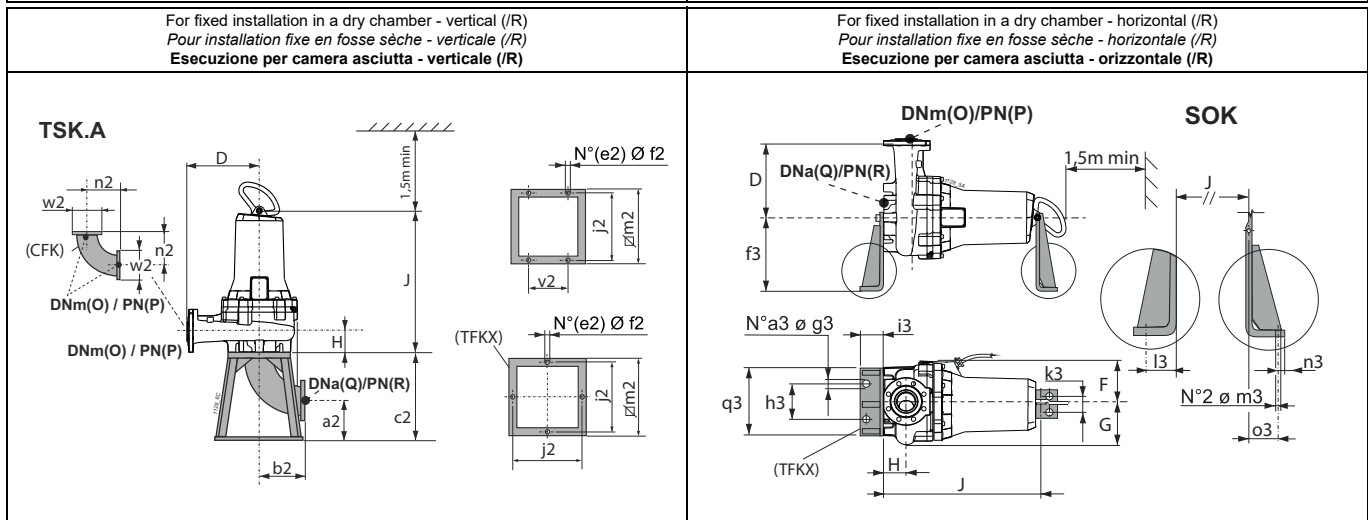
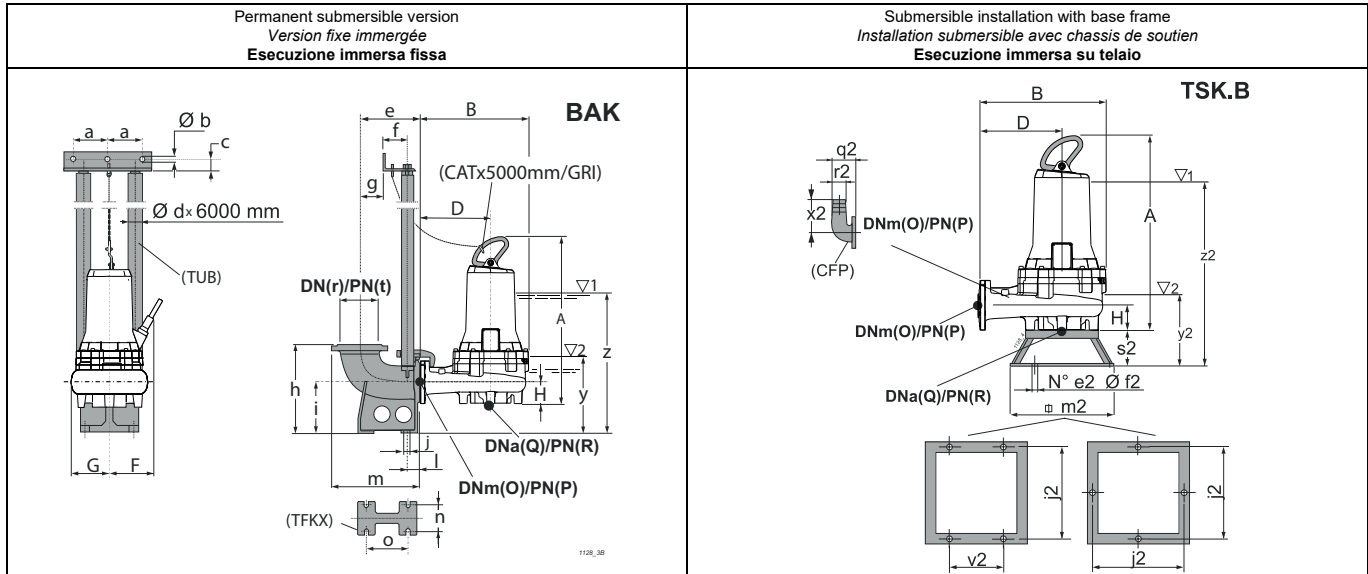

Type Type Tipo	Free passage Passage libre Passaggio Libero	Weight Poids Peso	A	B	D	F	G	H	J	O	P	Q	R	Accessories Accessoires Accessori				
			[mm]	[kg]	[mm]											BAK.	SOK.	TSK.A
KCA150HP+002141N3	Ø ---	126,6	659,3	570	344	224,2	241,2	131,5	574	150	16	150	16(*)	VI 2"	150/N3	I	M	
KCA150HL+002941N3	Ø ---	141,7	659,3	570	344	224,2	241,2	131,5	574	150	16	150	16(*)	VI 2"	150/N3	I	M	
KCA150HG+003741N3	Ø ---	141,9	728,4	570	344	224,2	241,2	131,5	610	150	16	150	16(*)	VI 2"	150/N3	I	M	
KCA150HD+004641N3	Ø ---	142,5	728,4	570	344	224,2	241,2	131,5	610	150	16	150	16(*)	VI 2"	150/N3	I	M	
KCA150HA+005842N3	Ø ---	151,9	728,4	570	344	224,2	241,2	131,5	610	150	16	150	16(*)	VI 2"	150/N3	I	M	
BAK.	a	b	c	d	e	f	g	h	i	j	l	m	n	o	r	t	y	z
BAKVI 2"	158	12,5	35	2"	260	102	75	435	235	19	59	403	194	214	150	16	312,5	567,5
SOK.	a3	f3	g3	h3	i3	k3	l3	m3	n3	o3	q3							
SOK150/N3	2	400	22	320	100	100	66	22	34	43	470							
TSK.A	a2	b2	c2	e2	f2	j2	m2	n2	v2	w2								
TSKIA	205	395	600	4	22	600	650	395	-	285								
TSK.B	e2	f2	j2	m2	q2	r2	s2	v2	x2	y2	z2							
TSKMB	4	14	600	650	315	150	220	350	380	429	684							

(3) z = Minimum submergence depth for motor without casing with continuous duty S1 (NPSHR permitting)

y = Minimum submergence depth for motor without casing with intermittent duty S3 (NPSHR permitting)

(*) Consult the flanges page.

(3) z = Immersion minimum pour moteur sans chemise en service continu S1 (compatible avec le NPSHR)

y = Immersion minimum pour moteur sans chemise en service intermittent S3 (compatible avec le NPSHR)

(*) Voir page brides.

(3) z = Immersion minima per motore senza mantello in funzione continuo S1 compatibilmente con l'NPSHR

y = Immersione minima con motore senza mantello in funzione intermittente S3 compatibilmente con l'NPSHR

(*) Vedere pagina flange.

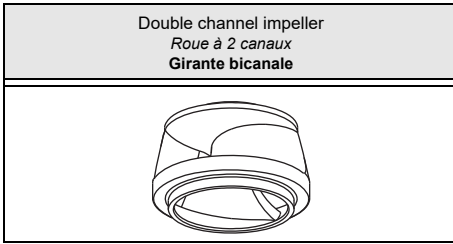

Type Type Tipo	KCD200N...62N3	KCD200N...62X3
Thermal probes Sondes thermiques Sonde termiche	Yes Oui Sì	Yes Oui Sì
Conductivity probe Sonde de conductivité Sonda di conduttività	Yes Oui Sì	Yes Oui Sì

Version cable (1)
Version câble (1)
Cavo Versione (1)

Electric pump type Electropompe type Elettropompa tipo	Power supply Alimentation Alimentazione	Auxiliary Auxiliaire Ausiliario
KCD200NL+007562N3	1x(10x2,5)x10	
KCD200NG+007562N3	1x(10x2,5)x10	
KCD200NA+007562N3	1x(10x2,5)x10	

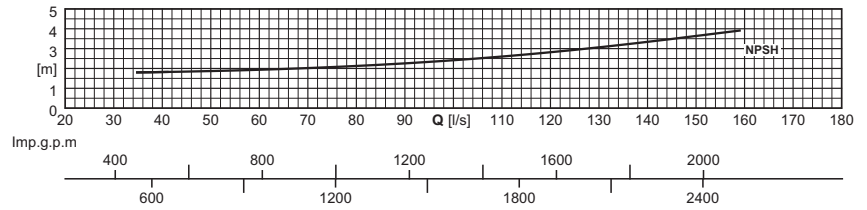
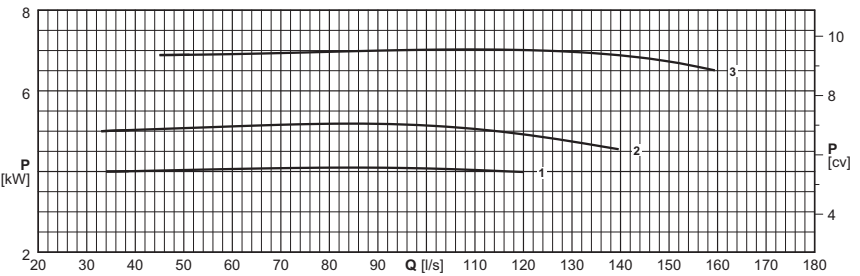
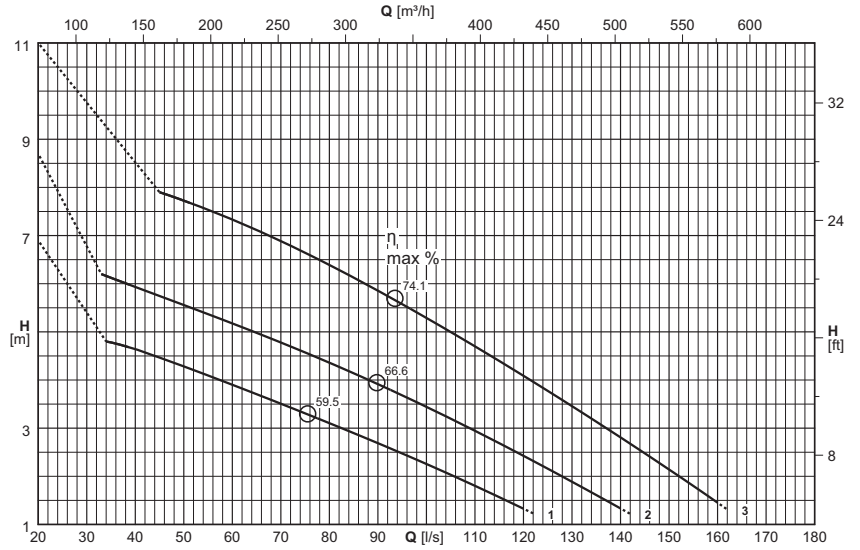

(1) = n°. of cables x (n°. of wires each cable x size [mm²]) x cable length [m] - Cable NSSHOU-J
Cable length exceeding 10 m on request

(1) = n°. câbles x (n°. conducteurs câble x section [mm²]) x longueur câble [m] - Câble NSSHOU-J
Sur demande longueur de câble supérieure à 10 m

(1) = n°. cavi x (n°. conduttori per cavo x sezione [mm²]) x lunghezza cavo [m] - Cavo NSSHOU-J
Lunghezza cavo superiore a 10 m - su richiesta

Electric pump type Electropompe type Elettropompa tipo	Curve Courbe Curva	Motor power Puiss. moteur Potenza motore	Capacity Débit Portata															
			[l/s]	0	35	40	45	50	60	70	80	90	100	125	150	162		
	(N°)	[kW]	[m³/h]	0	126	144	162	180	216	252	288	324	360	450	540	583,2		
			Head Hauteur Prevalenza															
			[m]	5,9	4,8	4,6	4,5	4,3	3,9	3,5	3,1	2,7	2,3					
KCD200NL+007562N3	1	7,5	[m]	5,9	4,8	4,6	4,5	4,3	3,9	3,5	3,1	2,7	2,3					
KCD200NG+007562N3	2	7,5	[m]	7,7	6,1	5,9	5,7	5,6	5,2	4,8	4,4	3,9	3,4	2,2				
KCD200NA+007562N3	3	7,5	[m]	10,4			7,9	7,7	7,3	6,9	6,4	5,9	5,3	3,8	2,1	1,3		
NPSH _R			[m]		1,8	1,8	1,8	1,9	1,9	2	2,1	2,3	2,4	2,9	3,6	4		

P₂ = Power rated by the motor
Performance tolerance as per:
UNI/ISO 9906 Grade 3B

For motor performances specification see page "motor features"

For the accessories specification see page "Accessories"

The impellers will be trimmed to meet the duty point

P₂ = Puissance restituée par le moteur
Tolérances sur les performances selon normes:
UNI/ISO 9906 Niveau 3B

Pour caractéristiques techniques moteurs voir page "Caractéristiques des moteurs"

Pour les accessoires voir page "Accessories"

Le point de fonctionnement désiré peut être obtenu par rognage de roue

P₂ = Potenza resa dal motore

Tolleranze sulle prestazioni secondo norme:
UNI/ISO 9906 Grado 3B

Per caratteristiche motori vedere pagina "caratteristiche motori"

Per accessori vedere pagina accessori

Le giranti vengono tornite in modo da ottenere il punto di lavoro richiesto

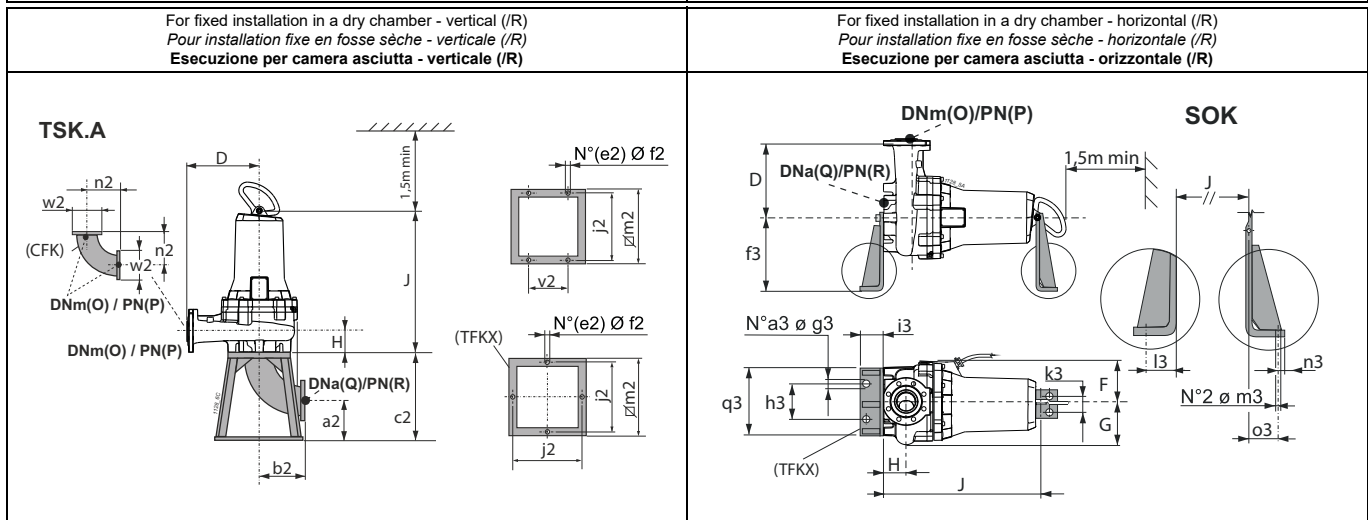
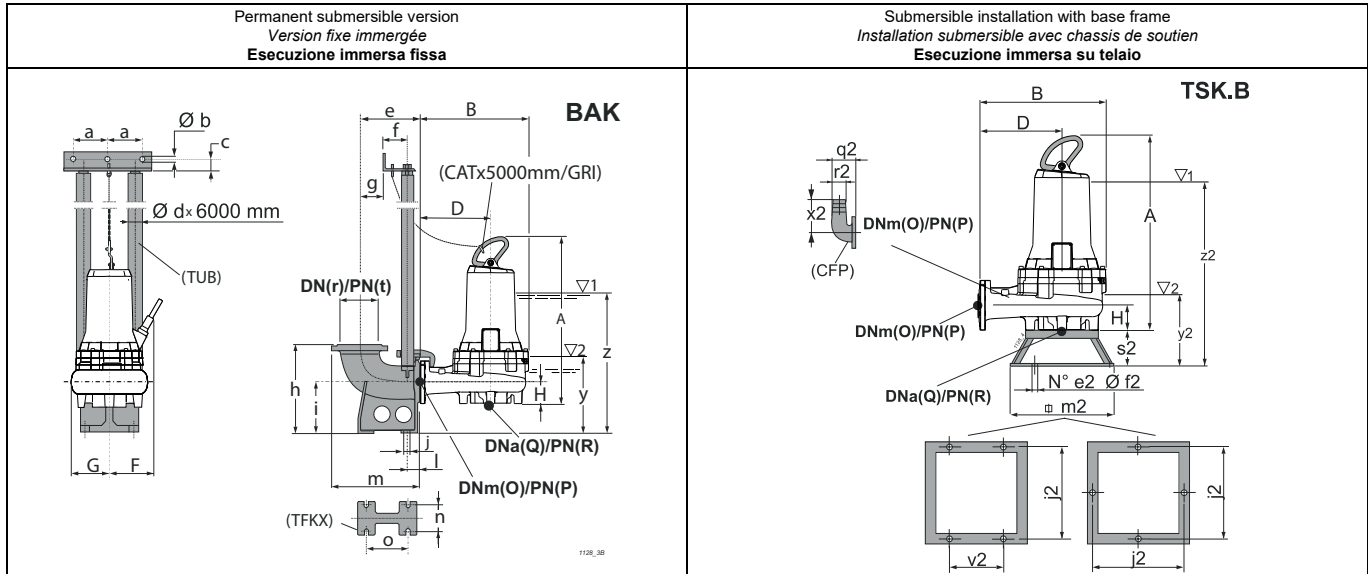

Type Type Tipo	Free passage Passage libre Passaggio Libero	Weight Poids Peso	A	B	D	F	G	H	J	O	P	Q	R	Accessories Accessoires Accessori				
			[mm]	[kg]	[mm]											BAK.	SOK.	TSK.A
KCD200NL+007562N3	Ø 100x110	235	846,9	840	550	240	340	170	727,5	200	10	200	10	N/M 3"	150/N3	M	M	
KCD200NG+007562N3	Ø 100x110	235,3	846,9	840	550	240	340	170	727,5	200	10	200	10	N/M 3"	150/N3	M	M	
KCD200NA+007562N3	Ø 100x110	236,7	846,9	840	550	240	340	170	727,5	200	10	200	10	N/M 3"	150/N3	M	M	
BAK.	a	b	c	d	e	f	g	h	i	j	l	m	n	o	r	t	y	z
BAKN/M 3"	157,5	12,5	35	3"	425	117	220	595	345	24	80	623	250	380	250	10	465	791
SOK.	a3	f3	g3	h3	i3	k3	l3	m3	n3	o3	q3							
SOK150/N3	2	400	22	320	100	100	66	22	34	43	470							
TSK.A	a2	b2	c2	e2	f2	j2	m2	n2	v2	w2								
TSKMA	290	310	600	4	22	600	650	310	-	340								
TSK.B	e2	f2	j2	m2	q2	r2	s2	v2	x2	y2	z2							
TSKMB	4	14	600	650	420	200	220	350	480	510	836							

(3) z = Minimum submergence depth for motor without casing with continuous duty S1 (NPSHR permitting)
y = Minimum submergence depth for motor without casing with intermittent duty S3 (NPSHR permitting)

(3) z = Immersion minimum pour moteur sans chemise en service continu S1 (compatible avec le NPSHR)
y = Immersion minimum pour moteur sans chemise en service intermittent S3 (compatible avec le NPSHR)

(3) z = Immersion minima per motore senza mantello in funzione continuo S1 compatibilmente con l'NPSHR
y = Immersione minima con motore senza mantello in funzione intermittente S3 compatibilmente con l'NPSHR

The following are also available: Anchoring bolts, level regulators and Electric panels

Accessoires supplémentaires: Tire-fond, Régulateurs de niveau et coffrets électriques

Sono inoltre disponibili: tirafondi, regolatori di livello e quadri elettrici

Duck-foot pedestal for automatic coupling (*) Pied d'assise pour accouplement automatique (*) Piede di accoppiamento automatico (*)	Type Type Tipo	A		B		Weight Poids Peso [Kg]	Electric pump type Electropompe type Elettropompa tipo															
		DN	UNI PN	DN	UNI PN		KCW080H	KCW080L	KCM080F	KCM080H	KCM080L	KCA080H	KCA080L	KCW100H	KCW100L	KCM100H	KCA100H	KCA100L	KCM150H	KCM150L	KCA150H	KCD200N
	BAKF 2"	80	ex PN10	80	16	26	●	●	●	●	●	●	●	-	-	-	-	-	-	-	-	-
	BAKF-A 2"	80	16	80	16	26	●	●	●	●	●	●	●	-	-	-	-	-	-	-	-	-
	BAKG 2"	100	16	100	16	30	-	-	-	-	-	-	●	●	●	●	●	-	-	-	-	-
	BAKG/F 2"	100	16	80	16	30	●	●	●	●	●	●	-	-	-	-	-	-	-	-	-	-
	BAKNM 3"	250	10	200	10	132	-	-	-	-	-	-	-	-	-	-	-	-	-	-	-	●
BAKVI 2"	150	16	150	16	50	-	-	-	-	-	-	-	-	-	-	-	-	●	●	●	-	

(*) = Complete with:

Pump coupling bracket (nodular cast iron)
Rail pipes anchor bracket (stainless steel)
Screw and nuts

(*) = Composé de:

Support de guidage (fonte à graphite sphéroïdale)
Support de barre de guidage (acier inox)
Visserie

(*) = Completo di:

Staffa corpo premente (ghisa sferoidale)
Staffa per tubi guida (acciaio inox)
Minuteria

Rail pipes (*) (dipped galvanized steel) Barres de guidage (*) (acier galvanisé à chaud) Tubi guida (*) (acciaio zincato a caldo)	Type Type Tipo	Weight Poids Peso [Kg]	Electric pump type Electropompe type Elettropompa tipo																	
			KCW080H	KCW080L	KCM080F	KCM080H	KCM080L	KCA080H	KCA080L	KCW100H	KCW100L	KCM100H	KCA100H	KCA100L	KCM150H	KCM150L	KCA150H	KCD200N		
	TUB 2"	21	●	●	●	●	●	●	●	●	●	●	●	●	●	●	●	●	●	-
	TUB 3"	51	-	-	-	-	-	-	-	-	-	-	-	-	-	-	-	-	-	●

(*) = On demand: stainless steel

(*) = Sur demande: acier inox

(*) = Su richiesta: acciaio inox

Chain and Shackle Kit (*) Kit Chaîne et manille (*) Kit Catena e Grillo (*)	Type Type Tipo	Max load Portée max Portata max [Kg]	Length Longueur Lunghezza [m]	Electric pump type Electropompe type Elettropompa tipo																
				KCW080H	KCW080L	KCM080F	KCM080H	KCM080L	KCA080H	KCA080L	KCW100H	KCW100L	KCM100H	KCA100H	KCA100L	KCM150H	KCM150L	KCA150H	KCD200N	
	CAT D.8 / GRL D.10	250	5	●	-	●	●	-	●	-	-	-	●	●	-	-	-	-	-	-
	CAT D.10 / GRL D.11	400	5	-	●	-	-	●	-	●	●	●	-	-	●	●	●	●	●	-
	CAT D.14 / GRL D.16	2500	5	-	-	-	-	-	-	-	-	-	-	-	-	-	-	-	-	●

(*) = On demand: stainless steel

(*) = Sur demande: acier inox

(*) = Su richiesta: acciaio inox

Base frame (dipped galvanized steel) Chassis de soutien (acier galvanisé) Telaio di sostegno (acciaio zincato a caldo)	Type Type Tipo	Weight Poids Peso [Kg]	Electric pump type Electropompe type Elettropompa tipo																
			KCW080H	KCW080L	KCM080F	KCM080H	KCM080L	KCA080H	KCA080L	KCW100H	KCW100L	KCM100H	KCA100H	KCA100L	KCM150H	KCM150L	KCA150H	KCD200N	
	TSKMB	20	-	-	-	-	-	-	-	-	-	-	-	-	●	●	●	●	-
	TSK30B	8,5	●	●	-	● (*)	●	●	●	-	-	-	-	-	-	-	-	-	-
	TSK100B	18,5	-	-	-	● (4P) (*)	-	-	-	●	●	●	●	●	-	-	-	-	-

(*) = DNa (Q) = 80
(*) = DNa (Q) = 100

(*) = DNa (Q) = 80
(*) = DNa (Q) = 100

(*) = DNa (Q) = 80
(*) = DNa (Q) = 100

Flanged hose connection (dipped galvanized steel) Coude pour tuyauterie souple (acier galvanisé à chaud) Curva flangiata portagomma (acciaio zincato a caldo)	Type Type Tipo	Weight Poids Peso [Kg]	Electric pump type Electropompe type Elettropompa tipo																
			KCW080H	KCW080L	KCM080F	KCM080H	KCM080L	KCA080H	KCA080L	KCW100H	KCW100L	KCM100H	KCA100H	KCA100L	KCM150H	KCM150L	KCA150H	KCD200N	
	CFP80	7	●	●	●	●	●	●	●	-	-	-	-	-	-	-	-	-	-
	CFP100	9	-	-	-	-	-	-	-	●	●	●	●	●	-	-	-	-	-
	CFP150	18	-	-	-	-	-	-	-	-	-	-	-	-	●	●	●	●	-
	CFP200	30	-	-	-	-	-	-	-	-	-	-	-	-	-	-	-	-	●

Supports (Steel with protective paint) Support de soutien (Acier revêtu de peinture de protection) Supporti (acciaio con vernice protettiva)	Type Type Tipo	Weight Poids Peso [Kg]	Electric pump type Electropompe type Elettropompa tipo																
			KCW080H	KCW080L	KCM080F	KCM080H	KCM080L	KCA080H	KCA080L	KCW100H	KCW100L	KCM100H	KCA100H	KCA100L	KCM150H	KCM150L	KCA150H	KCD200N	
	SOK100/N3	34,5	-	-	-	2,9-3,7-4,6-5,8	-	-	-	-	2,1-2,9-3,7-4,6-5,8	4-7,5-10,5-12,5	1,5-1,8-2,9-3,7-4,6-5,8	2,9-3,7-4,6-5,8	7,5-10,5-12,5	-	-	-	-
	SOK150/N3	26,5	-	-	-	-	-	-	-	-	-	-	-	-	-	4,6-5,8	4-7,5-10,5-12,5	2,1-2,9-3,7-4,6-5,8	7,5
	SOK80/N3	26,5	1,5-1,6-2,1-2,9-3,7-4,6-4,8-5,8-6,5-9	12,5-16,5	-	1,5-1,6-2,1-2,9	6,5-9-12,5-16,5	1,6-2,1-2,9	6,5-9-12,5-16,5	-	-	-	-	-	-	-	-	-	-

Handle in stainless steel (*) Manille de soulèvement en acier inox (*) Maniglia di aggancio in acciaio inox (*)	Type Type Tipo	Weight Poids Peso [Kg]	Electric pump type Electropompe type Elettropompa tipo																
			KCW080H	KCW080L	KCM080F	KCM080H	KCM080L	KCA080H	KCA080L	KCW100H	KCW100L	KCM100H	KCA100H	KCA100L	KCM150H	KCM150L	KCA150H	KCD200N	
	MAN-235/3	0,5	-	-	•	-	-	-	-	-	-	-	-	-	-	-	-	-	-

(*) = Complete with screw and bolts

(*) = Complète de visserie

(*) = Completa di minuteria

Base frame (dipped galvanized steel) Chassis de soutien (acier galvanisé) Telaio di sostegno (acciaio zincato a caldo)	Type Type Tipo	A		B		Weight Poids Peso [Kg]	Electric pump type Electropompe type Elettropompa tipo															
		DN	UNI PN	DN	UNI PN		KCW080H	KCW080L	KCM080F	KCM080H	KCM080L	KCA080H	KCA080L	KCW100H	KCW100L	KCM100H	KCA100H	KCA100L	KCM150H	KCM150L	KCA150H	KCD200N
			TSKIA	150	16		150	16	50	-	-	-	-	-	-	-	-	-	-	-	•	•
TSKMA	200		10	200	10	70	-	-	-	-	-	-	-	-	-	-	-	-	-	-	•	
TSKK80A	80		16 (*)	80	16 (*)	35	•	•	-	•	•	•	•	-	-	-	-	-	-	-	-	
TSK100A	100		16	100	16	34	-	-	-	• (4P)	-	-	-	•	•	•	•	•	-	-	-	

(*) = Fixed installation in a dry chamber

(*) = Installation fixe en fosse

(*) = Esecuzione per camera asciutta

Flanged elbow (dipped galvanized steel) Coude bridé (acier galvanisé à chaud) Curva flangiata (acciaio zincato a caldo)	Type Type Tipo	A		B		Weight Poids Peso [Kg]	Electric pump type Electropompe type Elettropompa tipo															
		DN	UNI PN	DN	UNI PN		KCW080H	KCW080L	KCM080F	KCM080H	KCM080L	KCA080H	KCA080L	KCW100H	KCW100L	KCM100H	KCA100H	KCA100L	KCM150H	KCM150L	KCA150H	KCD200N
			CFK80	80	16		80	16	10,5	•	•	-	•	•	•	•	-	-	-	-	-	-
CFK100	100		16	100	16	12	-	-	-	-	-	-	•	•	•	•	•	-	-	-	-	
CFK150	150		16	150	16	25,5	-	-	-	-	-	-	-	-	-	-	-	•	•	•	-	
CFK200	200		10	200	10	31	-	-	-	-	-	-	-	-	-	-	-	-	-	-	•	

50 Hz motor features (*N/X)
Caractéristiques des moteurs à 50 Hz (*N/X)
Caratteristiche motori a 50 Hz (*N/X)

Poles Pôles Poli	Motor type Moteur type Motore tipo	Motor power Puiss. moteur Potenza motore		Absorption Intensité Assorbimento	Direct starting Démarrage direct Avviamento diretto	Direct starting2 Démarrage direct2 Avviamento diretto2		Starts / hour max Max démarrages / heure Max avviamenti/ora	Degree of intermittence Degré d'intermittence Grado di intermittenza
		P ₁	P ₂	IN (400V)		(Standard)			
		[kW]		[A]		I _S /I _N	Direct Direct Diretto		
6	KC00156..H112..	1,84	1,5	3,4	5,6	●		20	50
	KC00186..H132..	2,1	1,8	4,1	7,2	●		20	40
	KC00406..L132..	4,71	4	9	5,8	●		20	40
	KC00756..N160..	8,46	7,5	15,8	7,3	●	●	15	30
4	KC00164..F100..	1,89	1,6	3,7	6,6	●		20	30
	KC00164..H112..	1,87	1,6	3,4	7,4	●		20	30
	KC00214..F100..	2,46	2,1	5,1	7,7	●		20	30
	KC00214..H112..	2,4	2,1	5	8,1	●		20	30
	KC00294..H112..	3,35	2,9	6,1	6,6	●		20	30
	KC00374..H132..	4,22	3,7	7,7	6,8	●		20	25
	KC00464..H132..	5,22	4,6	9,5	6,1	●		20	25
	KC00584..H132..	6,58	5,8	11,9	6,7	●	●	20	30
	KC00754..L132..	8,41	7,5	15,3	7,7	●	●	15	25
	KC01054..L160..	11,56	10,5	20	6,2	●	●	15	20
KC01254..L160..	13,79	12,5	24	6	●	●	10	20	
2	KC00482..H112..	5,5	4,8	8,9	9,2	●		20	25
	KC00652..H132..	7,34	6,5	11,9	9,2	●	●	15	30
	KC00652..L132..	7,34	6,5	11,8	9,3	●	●	15	35
	KC00902..H132..	10	9	16,3	8,8	●	●	15	35
	KC00902..L132..	10	9	16,1	8,9	●	●	15	35
	KC01252..L132..	13,79	12,5	22,4	8,6	●	●	10	30
KC01652..L160..	18,11	16,5	31	8,9	●	●	10	25	

*N = Standard version

*X = Explosion-proof version

P₁ = Power absorbed by the motor

P₂ = Power rated by the motor

I_N = Rated current

I_S = Starting current

- The electric pumps are suitable for S1 continuous service with submersed motor and for S3 intermittent service (see relative degrees of intermittence in the table) with non-submersed motor.

S3 service stands for intermittent service consisting of 10 minute equal cycles of which the previous table indicates the minutes of the cycle during which the motor may operate (eg. : S3 = 25% operation consists of a repetitive sequence of 2,5 minutes operation and 7,5 minutes at a standstill). See standard CEI EN 60034-1

- The electric motors are produced in the following voltage ratings: 400 V ± 10% standard; 230 V ± 10% on request.

Other voltages on request.

*N = Version standard

*X = Version antidéflagrante

P₁ = Puissance absorbée par le moteur

P₂ = Puissance restituée par le moteur

I_N = Intensité nominale

I_S = Intensité au démarrage

- L'électropompe est apte à fonctionner en service continu S1 avec le moteur complètement immergé, en service intermittent S3 moteur non immergé (se reporter aux valeurs d'intermittence mentionnées dans le tableau).

Le service S3 indique un fonctionnement intermittent par cycles identiques de 10 minutes. Le tableau ci-dessus indique le temps de marche du moteur en minutes pour 1 cycle de 10 minutes (Ex. : S3 = 25% chaque cycle sera composé de 2,5 minutes de marche et de 7,5 minutes d'arrêt). Voir norme CEI EN 60034-1.

- Les moteurs électriques prévus doivent être alimentés aux tensions nominales suivantes: 400 V ± 10% standard; 230 V ± 10% sur demande.

Tensions différentes sur demande.

*N = Versione standard

*X = Versione antideflagrante

P₁ = Potenza assorbita motore

P₂ = Potenza resa dal motore

I_N = Corrente nominale

I_S = Corrente di avviamento

- Le elettropompe sono atte a funzionare in servizio continuo S1 con motore immerso, in servizio intermittente S3 con motore non immerso (vedi relativi gradi di intermittenza nella tabella).

Il servizio S3 sta ad indicare un funzionamento intermittente composto da cicli tutti uguali di 10 minuti di cui si indicano i minuti del ciclo in cui il motore può funzionare (Es. : S3 = 25% il funzionamento è composto da una sequenza ripetitiva di 2,5 minuti di funzionamento e di 7,5 minuti di sosta). Vedi norma CEI EN 60034-1.

- I motori elettrici sono previsti per essere alimentati alle seguenti tensioni nominali di rete: 400 V ± 10% standard; 230 V ± 10% a richiesta.

Tensioni diverse su richiesta.

K+ DN 100÷250



Performance ranges
Champs de performance
Campi di prestazione

- KCW100N
- KCM100N
- KCM150N
- KCM200P
- KCD200N+01106..6P
- KCD200N(4)P
- KCD250P
- KCA100N
- KCA150N
- KCA200N

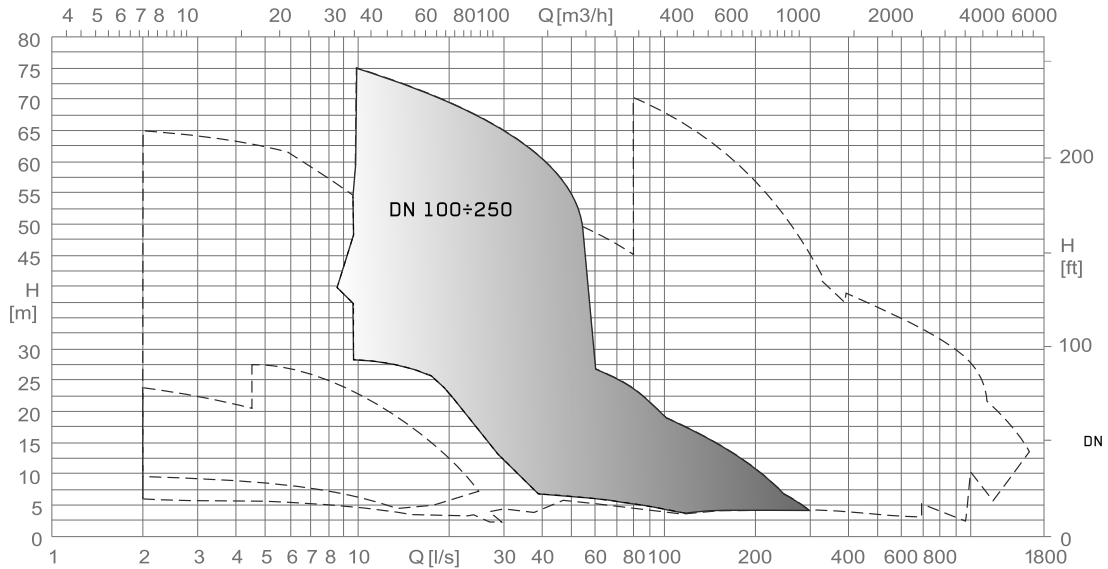

[Imp.g.p.m.]



[US.g.p.m.]



[l/min]



Electric pump coding
Exemplification du sigle de l'électropompe
Esemplificazione sigla elettropompa

KCW100N
KCM100N
KCM150N
KCM200P
KCD200N+01106..6P
KCD200N(4)P
KCD250P
KCA100N
KCA150N
KCA200N

Motor code match
Codes communs avec le sigle moteur
Comunanze con sigla motore

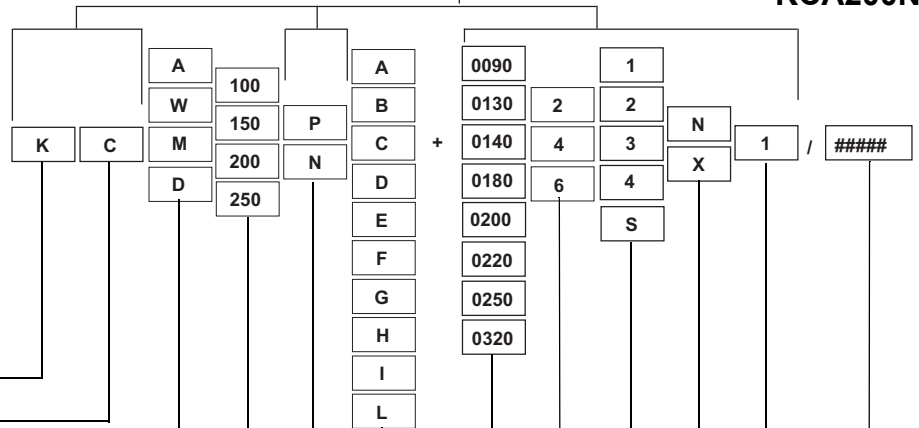

Series - Série - Serie _____

50 Hz _____

Impeller: open twin blade "A"; vortex "W";
single-channel "M"; double channel "D"
Roue: ouvert à deux aubes "A"; vortex "W";
monocanal "M"; à 2 canaux "D"
Girante: bipala aperta "A"; a vortice "W";
monocanale "M"; bicanale "D" _____

Size of pump end (DNm)
Grandeur partie hydraulique (DNm)
Grandezza parte idraulica (DNm) _____

Size of electric motor flanging
Dimension bride moteur électrique
Grandezza flangiatura motore elettrico _____

Impeller diameter - Réduction roue - Riduzione girante _____

Motor output power code
Code puissance rendemet moteur
Codice potenza resa motore _____

Number of poles - Nombre de pôles - Numero poli _____

Constructional features of electric motor threephase, class F insulation, IP68-IEC protection degree
Caractéristiques de fabrication moteur électrique triphasé, classe d'isolation F, degré de protection IP68-IEC
Caratteristiche costruttive motore elettrico trifase, classe di isolamento F, grado di protezione IP68-IEC
1 = 400 (380-415) V-Y
2 = 400 (380-415) V-Δ / 700 (660-720) V-Y
3 = 230 (220-240) V-Δ / 400 (380-415) V-Y
4 = 230 (220-240) V-Δ
S = Specials - Spéciaux - Speciali

Standard electric pump: (N); explosion-proof version: (X) (construction according to EN60079-0 EN60079-1 standards type ATEX II 2G Ex db h IIB T4 Gb and I M2 Ex db h I Mb)
Electropompe standard: (N); version antidéflagrante: (X) (la fabrication est conforme à la norme EN60079-0 - EN60079-1 type ATEX II 2G Ex db h IIB T4 Gb et I M2 Ex db h I Mb)
Elettropompa standard: (N); versione antideflagrante: (X) (la costruzione è conforme alle norme EN60079-0 - EN60079-1 tipo ATEX II 2G Ex db h IIB T4 Gb e I M2 Ex db h I Mb)

Generational code - Code générationnel - Codice generazionale _____

Various specialities - Spécialités diverses - Specialità varie _____

K+

DN 100÷250

caprari

KCW100N
KCM100N
KCM150N
KCM200P
KCD200N+
01106..6P
KCD200N(4)P
KCD250P

Construction and materials
Construction et matériaux
Costruzione e materiali

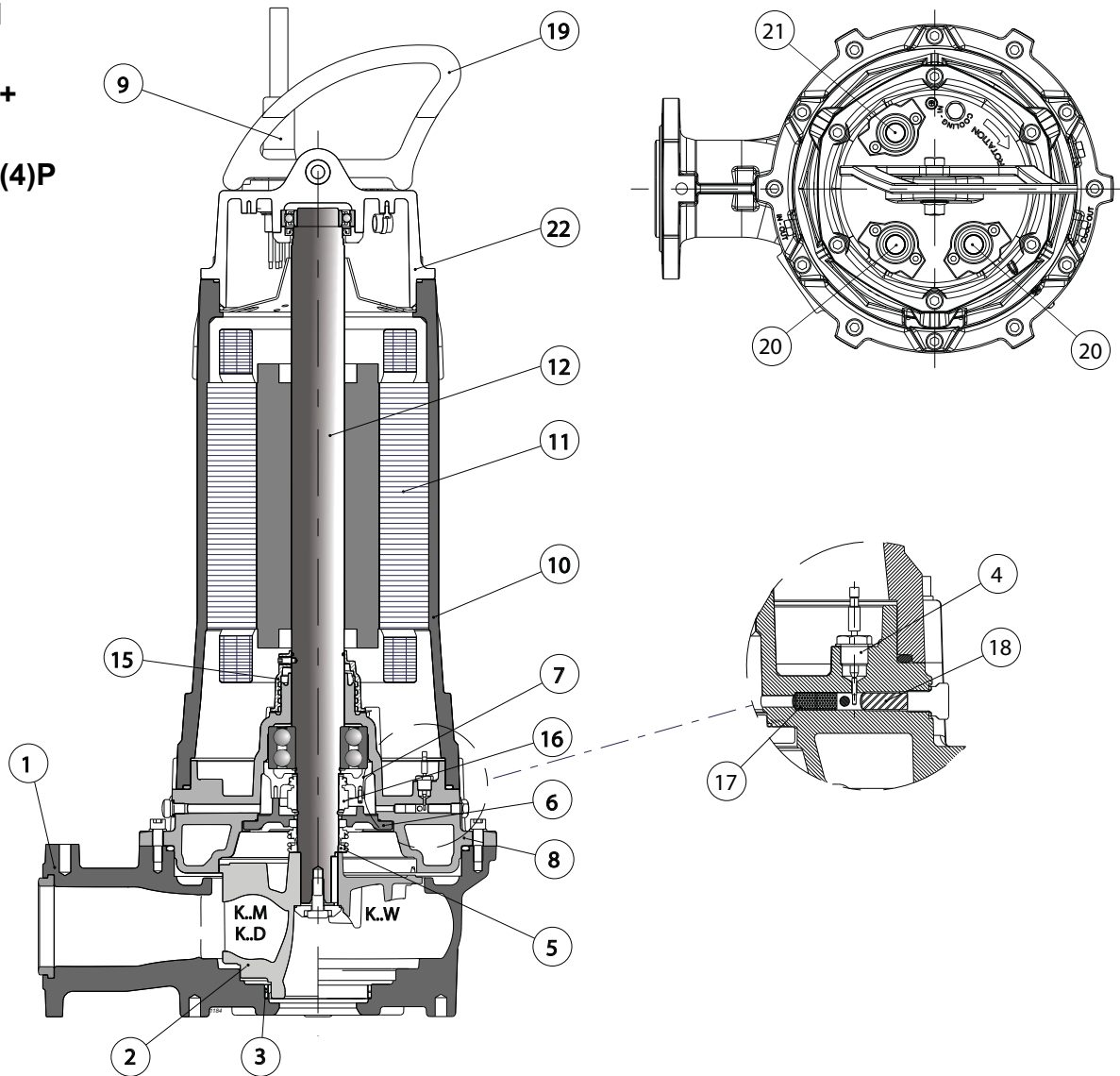

Pos.	Parts	Materials	Nomenclature	Matériaux	Nomenclatura	Materiale
1	Delivery body	Cast iron	Corps de refoulement	Fonte grise	Corpo mandata	Ghisa grigia
2	Impeller	Cast iron	Roue	Fonte grise	Girante	Ghisa grigia
3	Impeller wear ring	Steel/Rubber	Bague d'usure	Acier/Caoutchouc	Anello sede girante	Acciaio/Gomma
4	Conductivity probe	-	Sondes de conductivité	-	Sonda di conduttività	-
5	Mechanical seal on pump side	Silicon carbide/silicon carbide	Garniture mécanique côté pompe	Carbure de silicium/ carbure de silicium	Tenuta meccanica lato pompa	Carburo di silicio/ carburo di silicio
6	Flange for mechanical seal	Nodular cast iron	Bride porte garniture mécanique	Fonte sphéroïdale	Flangia porta tenuta meccanica	Ghisa sferoidale
7	Support bearing	Nodular cast iron	Support de roulement	Fonte sphéroïdale	Supporto cuscinetto	Ghisa sferoidale
8	Oil box	Cast iron	Chambre à huile	Fonte grise	Scatola olio	Ghisa grigia
9	Cable clamp	Stainless steel	Presse-étoupe	Acier inox	Pressacavo	Acciaio inox
10	Motor casing	Cast iron	Enveloppe du moteur	Fonte grise	Carcassa motore	Ghisa grigia
11	Stator	Electrical steel	Stator	Tôle magnétique	Statore	Lamierino magnetico
12	Complete shaft with rotor	Stainless steel/ Magnetic steel	Arbre avec rotor	Acier inox/Tôle magnétique	Albero completo di rotore	Acciaio inox/ Lamierino magnetico
15	Oil centrifuge	Technopolymer	Centrifugeur huile	Polymère technique	Centrifugatore olio	Tecnopolimero
16	Mechanical seal on motor side	Ceramic/graphite	Garniture mécanique côté moteur	Céramique/graphite	Tenuta meccanica lato motore	Ceramica/grafite
17	Flame arrester	Stainless steel	Arrête-Flamme	Acier inox	Arrestatore di fiamma	Acciaio inox
18	Diaphragm	Nitrile rubber	Membrane	Caoutchouc nitrile	Membrana	Gomma nitrilica
19	Handle	Stainless steel	Poignée	Acier inox	Maniglia	Acciaio inox
20	Round power cable	-	Câble rond d'alimentation	-	Cavo tondo di alimentazione	-
21	Round auxiliary cable	-	Câble rond auxiliaire	-	Cavo tondo ausiliario	-
22	Head cover	Cast iron	Couvercle tête	Fonte grise	Coperchio testata	Ghisa grigia

Screws and nuts in stainless steel.

Available version with AISI 316 stainless steel impeller.

Vis et écrous en acier inox

Disponibile version Avec roue en acier inox AISI 316.

Viti e dadi in acciaio inox

Disponibile versione con girante in acciaio inox AISI 316.

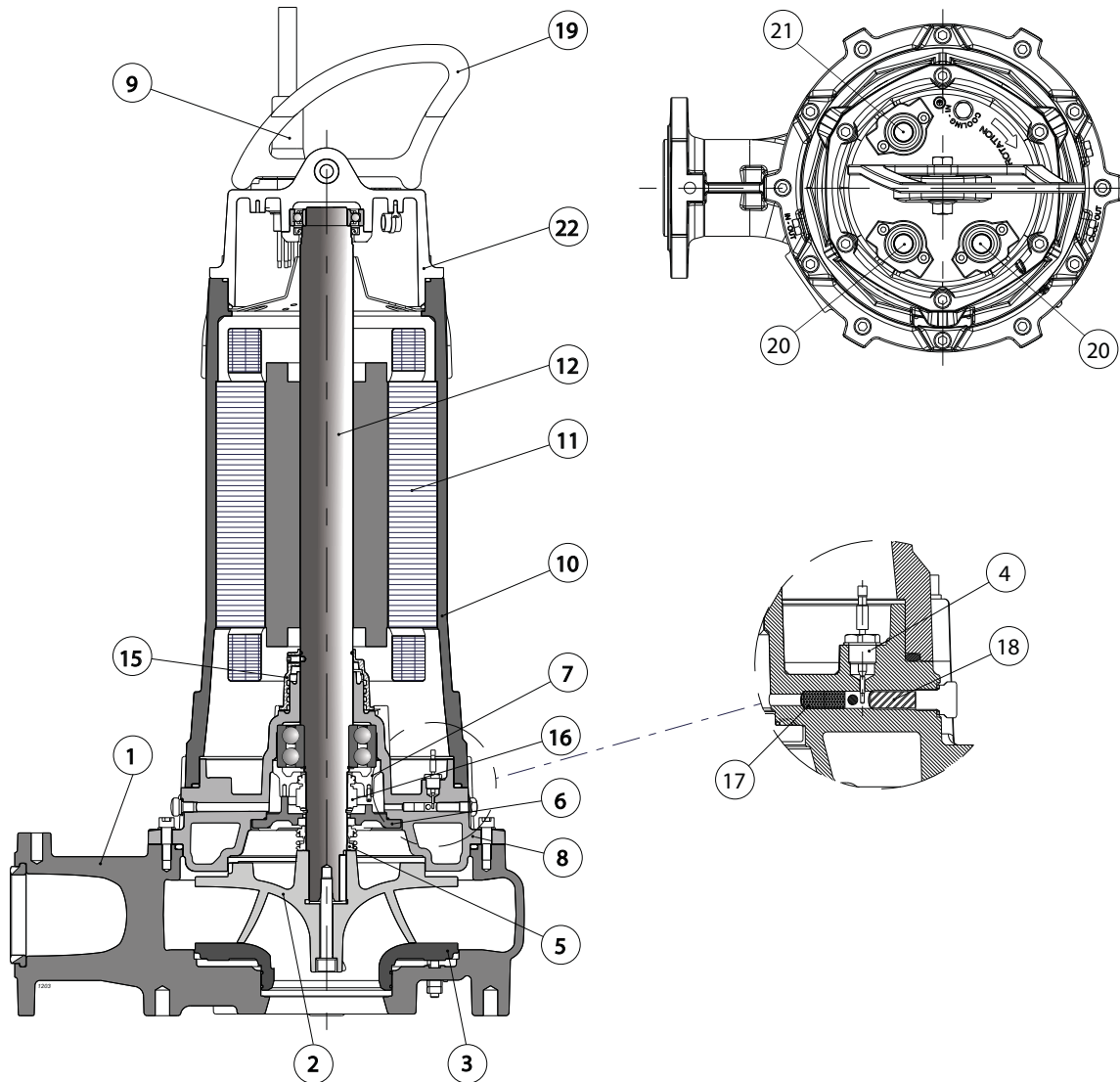

Pos.	Parts	Materials	Nomenclature	Matériaux	Nomenclatura	Materiale
1	Delivery body	Cast iron	Corps de refoulement	Fonte grise	Corpo mandata	Ghisa grigia
2	Impeller	Cast iron	Roue	Fonte grise	Girante	Ghisa grigia
3	Suction support	Nodular cast iron	Palier aspiration	Fonte sphéroïdale	Supporto aspirazione	Ghisa sferoidale
4	Conductivity probe	-	Sondes de conductivité	-	Sonda di conduttività	-
5	Mechanical seal on pump side	Silicon carbide/silicon carbide	Garniture mécanique côté pompe	Carbure de silicium/ carbure de silicium	Tenuta meccanica lato pompa	Carburo di silicio/ carburo di silicio
6	Flange for mechanical seal	Nodular cast iron	Bride porte garniture mécanique	Fonte sphéroïdale	Flangia porta tenuta meccanica	Ghisa sferoidale
7	Support bearing	Nodular cast iron	Support de roulement	Fonte sphéroïdale	Supporto cuscinetto	Ghisa sferoidale
8	Oil box	Cast iron	Chambre à huile	Fonte grise	Scatola olio	Ghisa grigia
9	Cable clamp	Stainless steel	Presse-étoupe	Acier inox	Pressacavo	Acciaio inox
10	Motor casing	Cast iron	Enveloppe du moteur	Fonte grise	Carcassa motore	Ghisa grigia
11	Stator	Electrical steel	Stator	Tôle magnétique	Statore	Lamierino magnetico
12	Complete shaft with rotor	Stainless steel/ Magnetic steel	Arbre avec rotor	Acier inox/Tôle magnétique	Albero completo di rotore	Acciaio inox/ Lamierino magnetico
15	Oil centrifuge	Technopolymer	Centrifugeur huile	Polymère technique	Centrifugatore olio	Tecnopolimero
16	Mechanical seal on motor side	Ceramic/graphite	Garniture mécanique côté moteur	Céramique/graphite	Tenuta meccanica lato motore	Ceramica/grafite
17	Flame arrester	-	Arrête-Flamme	-	Arrestatore di fiamma	-
18	Diaphragm	Nitrile rubber	Membrane	Caoutchouc nitrile	Membrana	Gomma nitrilica
19	Handle	Stainless steel	Poignée	Acier inox	Maniglia	Acciaio inox
20	Round power cable	-	Câble rond d'alimentation	-	Cavo tondo di alimentazione	-
21	Round auxiliary cable	-	Câble rond auxiliaire	-	Cavo tondo ausiliario	-
22	Head cover	Cast iron	Couvercle tête	Fonte grise	Coperchio testata	Ghisa grigia

• Cooling system components (Version .../R)

• Composant pour version avec système de refroidissement (Version .../R)

• Componenti sistema di raffreddamento (Versione .../R)

Screws and nuts in stainless steel.

Vis et écrous en acier inox

Viti e dadi in acciaio inox

Available version with AISI 316 stainless steel impeller.

Disponible version Avec roue en acier inox AISI 316.

Disponibile versione con girante in acciaio inox AISI 316.

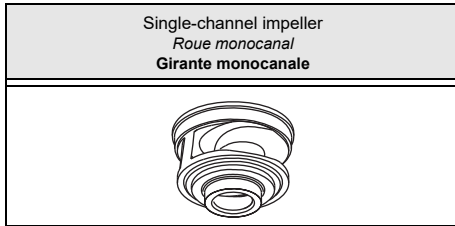

Type Type Tipo	KCM100N...+...42N3	KCM100N...+...42X3
Thermal probes Sondes thermiques Sonda termiche	Yes Oui Sì	Yes Oui Sì
Conductivity probe Sonde de conductivité Sonda di conduttività	Yes Oui Sì	Yes Oui Sì

Version cable (1) Version câble (1) Cavo Versione (1)		
Electric pump type Electropompe type Elettropompa tipo	Power supply Alimentation Alimentazione	Auxiliary Auxiliaire Ausiliario
KCM100NL+016542N3	2x(4x6)x10	1x(4x1,5)x10
KCM100NG+019342N3	2x(4x10)x10	1x(4x1,5)x10
KCM100ND+019342N3	2x(4x10)x10	1x(4x1,5)x10
KCM100NA+023042N3	2x(4x10)x10	1x(4x1,5)x10

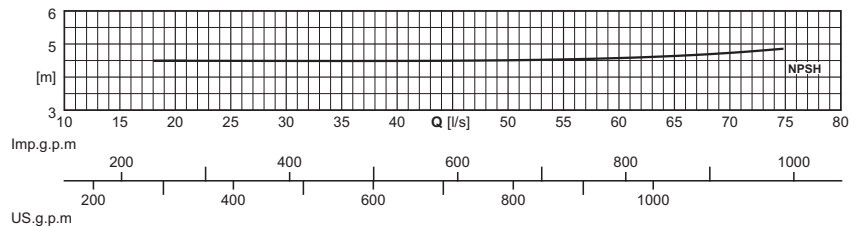
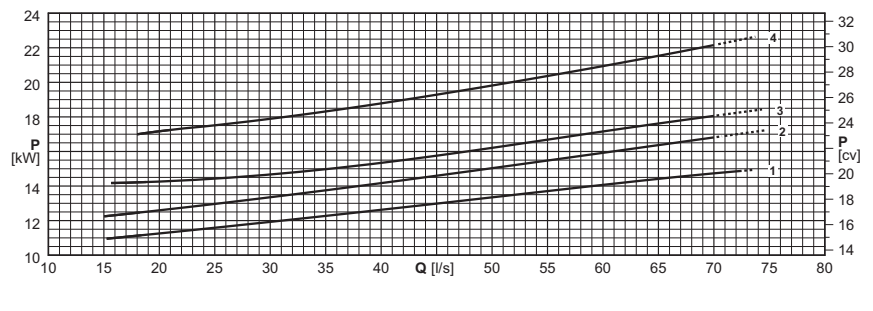
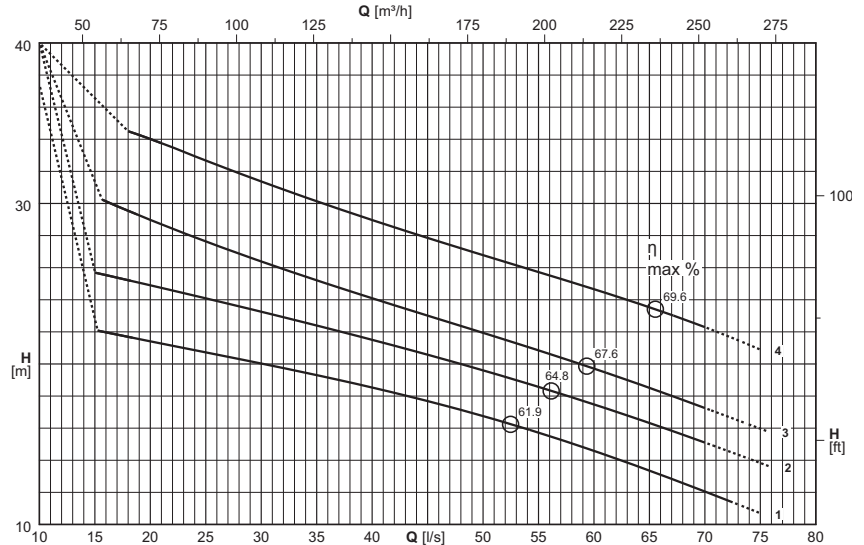

(1) = n°. of cables x (n°. of wires each cable x size [mm²]) x cable length [m] - Cable NSSHOU-J

Cable length exceeding 10 m on request

(1) = n°. câbles x (n°. conducteurs câble x section [mm²]) x longueur câble [m] - Câble NSSHOU-J

Sur demande longueur de câble supérieure à 10 m

(1) = n°. cavi x (n°. conduttori per cavo x sezione [mm²]) x lunghezza cavo [m] - Cavo NSSHOU-J

Lunghezza cavo superiore a 10 m - su richiesta

Electric pump type Electropompe type Elettropompa tipo	Curve Courbe Curva	Motor power Puiss. moteur Potenza motore	Capacity Débit Portata															
			[l/s]	0	20	25	30	35	40	45	50	55	60	65	70	75		
		P ₂	[m³/h]	0	72	90	108	126	144	162	180	198	216	234	252	270		
	(N°)	[kW]	Head Hauteur Prevalenza															
			[m]	27,4	21,4	20,7	20	19,3	18,5	17,7	16,8	15,7	14,6	13,4	12	10,7		
KCM100NL+016542N3	1	16,5	[m]	27,4	21,4	20,7	20	19,3	18,5	17,7	16,8	15,7	14,6	13,4	12	10,7		
KCM100NG+019342N3	2	19,3	[m]	31	24,9	24,1	23,3	22,4	21,5	20,6	19,6	18,6	17,5	16,3	15,1	13,8		
KCM100ND+019342N3	3	19,3	[m]	34,3	29	27,6	26,4	25,2	24,1	23	21,9	20,8	19,7	18,5	17,3	16		
KCM100NA+023042N3	4	23	[m]	39,6	34	32,7	31,4	30,1	29	27,9	26,8	25,7	24,7	23,5	22,3			
NPSH _R			[m]		4,5	4,5	4,5	4,5	4,5	4,5	4,5	4,5	4,6	4,6	4,7	4,9		

P₂ = Power rated by the motor

Performance tolerance as per: UNI/ISO 9906 Grade 3B

For motor performances specification see page "motor features"

For the accessories specification see page "Accessories"

P₂ = Puissance restituée par le moteur

Tolérances sur les performances selon normes: UNI/ISO 9906 Niveau 3B

Pour caractéristiques techniques moteurs voir page "Caractéristiques des moteurs"

Pour les accessoires voir page "Accessories"

P₂ = Potenza resa dal motore

Tolleranze sulle prestazioni secondo norme: UNI/ISO 9906 Grado 3B

Per caratteristiche motori vedere pagina "caratteristiche motori"

Per accessori vedere pagina accessori

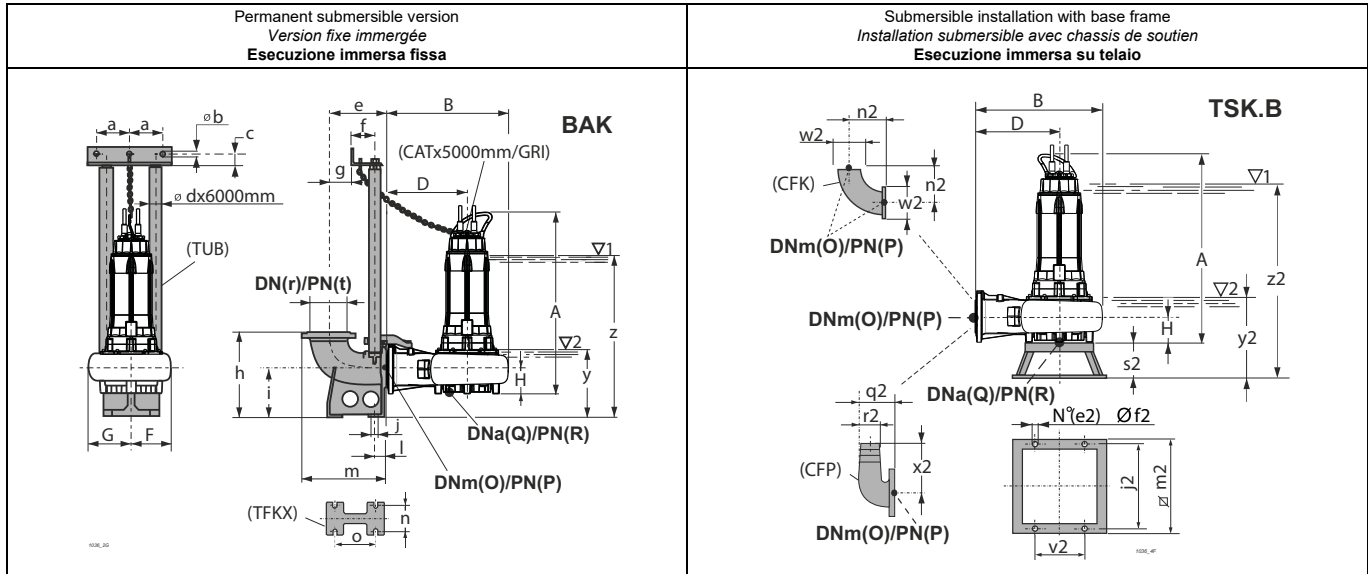

For fixed installation in a dry chamber - vertical (R)
Pour installation fixe en fosse sèche - verticale (R)
Esecuzione per camera asciutta - verticale (R)

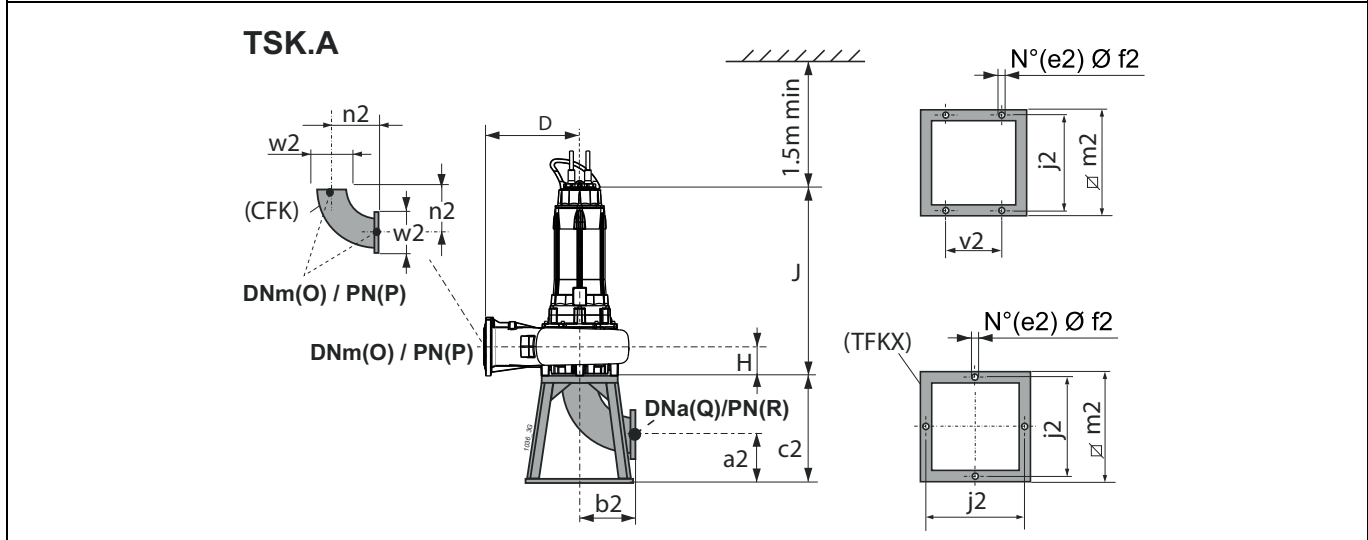

Type Type Tipo	Free passage Passage libre Passaggio Libero	Weight Poids Peso	A	B	D	F	G	H	J	O	P	Q	R	Accessories Accessoires Accessori				
			[mm]	[kg]	[mm]											BAK	TSK.A	TSK.B
KCM100NL+016542N3	Ø 100	350,05	1240	551	308	224	262	160	1085,5	100	16	150	16	100 2"	I	M		
KCM100NG+019342N3	Ø 100	371,93	1240	551	308	224	262	160	1085,5	100	16	150	16	100 2"	I	M		
KCM100ND+019342N3	Ø 100	372,82	1240	551	308	224	262	160	1085,5	100	16	150	16	100 2"	I	M		
KCM100NA+023042N3	Ø 100	397,85	1240	551	308	224	262	160	1085,5	100	16	150	16	100 2"	I	M		
BAK.	a	b	c	d	e	f	g	h	i	j	l	m	n	o	r	t	y	z
BAK100 2"	130	12,5	35	2"	228	102	48	430	280	18	49	338	194	186	100	16	454	1075
TSK.A	a2	b2	c2	e2	f2	j2	m2	n2	v2	w2								
TSKIA	205	395	600	4	22	600	650	204	-	220								
TSK.B	e2	f2	j2	m2	n2	q2	r2	s2	v2	w2	x2	y2	z2					
TSKMB	4	14	600	650	204	215	100	220	350	220	273	554	1175					

(3) z = Minimum submergence depth for motor without casing with continuous duty S1 (NPSHR permitting)
y = Minimum submergence depth for motor without casing with intermittent duty S3 (NPSHR permitting)

(3) z = Immersion minimum pour moteur sans chemise en service continu S1 (compatible avec le NPSHR)
y = Immersion minimum pour moteur sans chemise en service intermittent S3 (compatible avec le NPSHR)

(3) z = Immersion minima per motore senza mantello in funzione continuo S1 compatibilmente con l'NPSHR
y = Immersione minima con motore senza mantello in funzione intermittente S3 compatibilmente con l'NPSHR

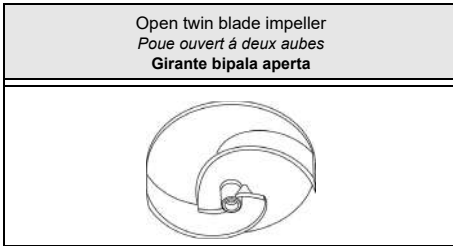

Type Type Tipo	KCA100N...42N3	KCA100N...42X3
Thermal probes Sondes thermiques Sonde termiche	Yes Oui Sì	Yes Oui Sì
Conductivity probe Sonde de conductivité Sonda di conduttività	Yes Oui Sì	Yes Oui Sì

Version cable (1) Version câble (1) Cavo Versione (1)		
Electric pump type Electropompe type Elettropompa tipo	Power supply Alimentation Alimentazione	Auxiliary Auxiliaire Ausiliario
KCA100NL+016542N3	2x(4x6)x10	1x(4x1,5)x10
KCA100NG+019342N3	2x(4x10)x10	1x(4x1,5)x10
KCA100ND+021042N3	2x(4x10)x10	1x(4x1,5)x10
KCA100NA+026042N3	2x(4x10)x10	1x(4x1,5)x10

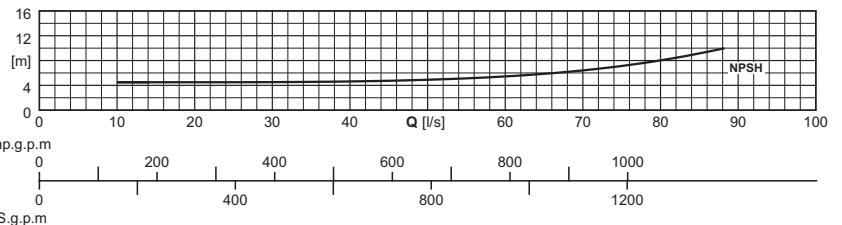
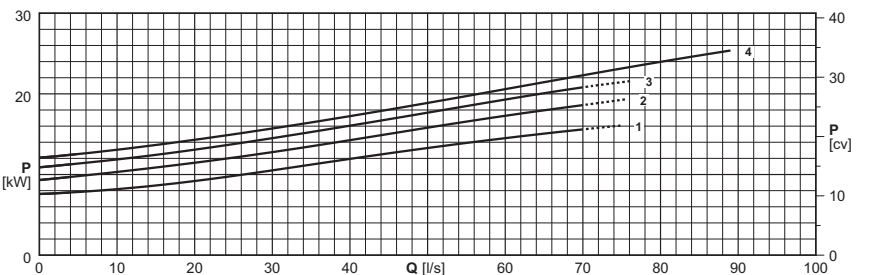
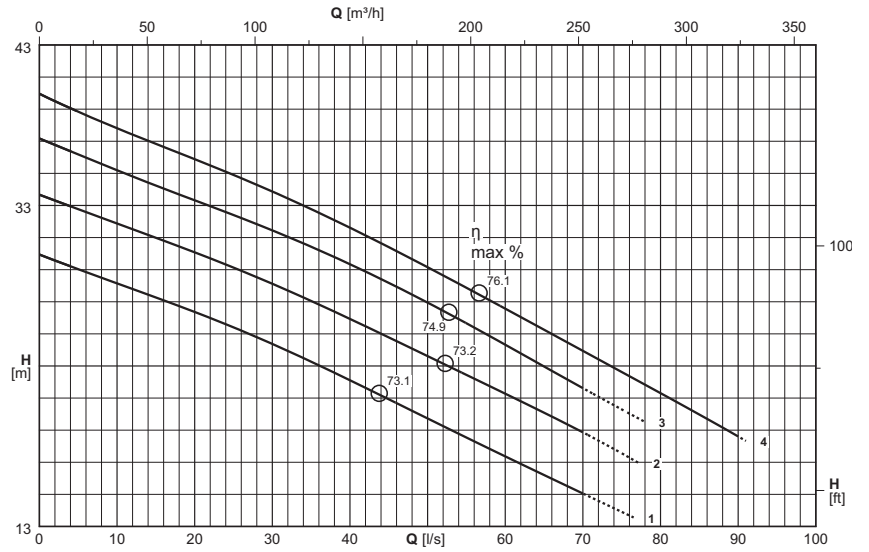

(1) = n°. of cables x (n°. of wires each cable x size [mm²]) x cable length [m] - Cable NSSHÖU-J
Cable length exceeding 10 m on request

(1) = n°. câbles x (n°. conducteurs câble x section [mm²]) x longueur câble [m] - Câble NSSHÖU-J
Sur demande longueur de câble supérieure à 10 m

(1) = n°. cavi x (n°. conduttori per cavo x sezione [mm²]) x lunghezza cavo [m] - Cavo NSSHÖU-J
Lunghezza cavo superiore a 10 m - su richiesta

Electric pump type Electropompe type Elettropompa tipo	Curve Courbe Curva	Motor power Puiss. moteur Potenza motore	Capacity Débit Portata																	
			[l/s]	0	5	10	15	20	25	30	35	40	45	50	60	70	80	90	91	
	(N°)	[kW]	[m ³ /h]	0	18	36	54	72	90	108	126	144	162	180	216	252	288	324	327,6	
			Head Hauteur Prevalenza																	
			[m]	29,9	29	28,1	27,3	26,4	25,4	24,4	23,3	22,1	20,9	19,7	17,4	15,1				
KCA100NL+016542N3	1	16,5	[m]	29,9	29	28,1	27,3	26,4	25,4	24,4	23,3	22,1	20,9	19,7	17,4	15,1				
KCA100NG+019342N3	2	19,3	[m]	33,7	32,8	31,9	31	30,1	29,1	28,1	27	25,9	24,8	23,6	21,3	18,9				
KCA100ND+021042N3	3	21	[m]	37,2	36,2	35,2	34,2	33,3	32,4	31,4	30,4	29,3	28,2	26,9	24,3	21,6				
KCA100NA+026042N3	4	26	[m]	40	38,8	37,8	36,8	35,9	34,9	33,9	32,8	31,6	30,4	29,1	26,6	23,9	21,3	18,6	18,3	
NPSH _R			[m]			4,5	4,5	4,5	4,5	4,5	4,6	4,6	4,7	4,9	5,4	6,4	8			
														4,9	5,4	6,4	8			
														4,8	5,2	6,1	7,7			

P₂ = Power rated by the motor
Performance tolerance as per:
UNI/ISO 9906 Grade 3B
For motor performances specification see page "motor features"

P₂ = Puissance restituée par le moteur
Tolérances sur les performances selon normes:
UNI/ISO 9906 Niveau 3B
Pour caractéristiques techniques moteurs voir page "Caractéristiques des moteurs"

P₂ = Potenza resa dal motore
Tolleranze sulle prestazioni secondo norme:
UNI/ISO 9906 Grado 3B
Per caratteristiche motori vedere pagina "caratteristiche motori"

For the accessories specification see page "Accessories"
The impellers will be trimmed to meet the duty point

Le point de fonctionnement désiré peut être obtenu par rognage de roue

Per accessori vedere pagina accessori
Le giranti vengono tornite in modo da ottenere il punto di lavoro richiesto

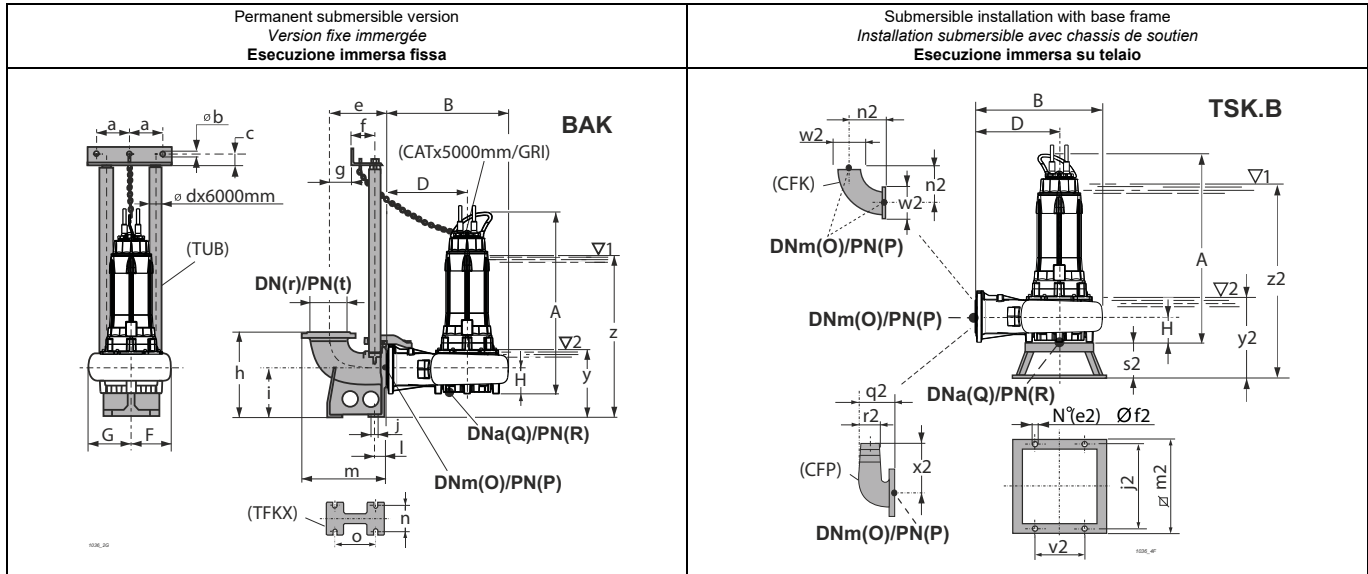

For fixed installation in a dry chamber - vertical (R)
Pour installation fixe en fosse sèche - verticale (R)
Esecuzione per camera asciutta - verticale (R)

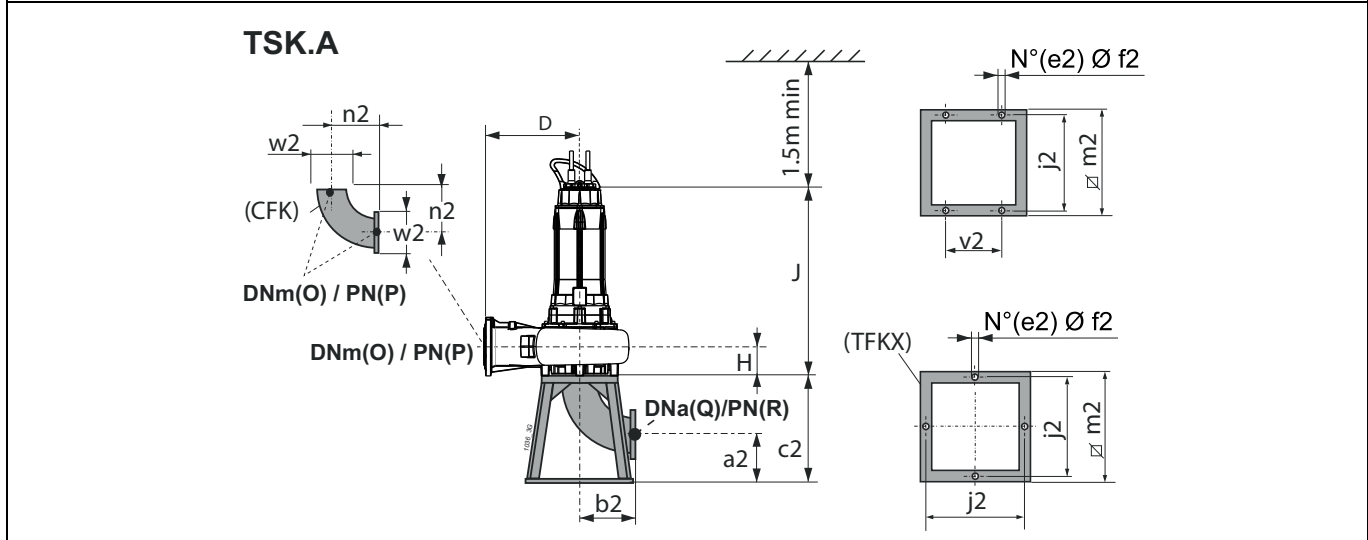

Type Type Tipo	Free passage Passage libre Passaggio Libero	Weight Poids Peso	A	B	D	F	G	H	J	O	P	Q	R	Accessories Accessoires Accessori		
			[mm]	[kg]	[mm]											BAK
KCA100NL+016542N3	---	342	1184,2	621,3	380	226,8	259,2	122,8	1029,7	100	16	150	16(*)	G 2"	I	M
KCA100NG+019342N3	---	364,6	1184,2	621,3	380	226,8	259,2	122,8	1029,7	100	16	150	16(*)	G 2"	I	M
KCA100ND+021042N3	---	397,1	1184,2	621,3	380	226,8	259,2	122,8	1029,7	100	16	150	16(*)	G 2"	I	M
KCA100NA+026042N3	---	373,5	1184,2	621,3	380	226,8	259,2	122,8	1029,7	100	16	150	16(*)	G 2"	I	M

BAK.	a	b	c	d	e	f	g	h	i	j	l	m	n	o	r	t	y	z
BAKG 2"	130	12,5	35	2"	228	102	48	350	200	18	49	338	135	186	100	16	355,4	976,4
TSK.A	a2	b2	c2	e2	f2	j2	m2	n2	v2	w2								
TSKIA	205	395	600	4	22	600	650	204	-	220								
TSK.B	e2	f2	j2	m2	n2	q2	r2	s2	v2	w2	x2	y2	z2					
TSKMB	4	14	600	650	204	215	100	220	350	220	273	498,2	1119,2					

(3) z = Minimum submergence depth for motor without casing with continuous duty S1 (NPSHR permitting)

y = Minimum submergence depth for motor without casing with intermittent duty S3 (NPSHR permitting)

(*) Consult the flanges page.

(3) z = Immersion minimum pour moteur sans chemise en service continu S1 (compatible avec le NPSHR)

y = Immersion minimum pour moteur sans chemise en service intermittent S3 (compatible avec le NPSHR)

(*) Voir page brides.

(3) z = Immersion minima per motore senza mantello in funzione continuo S1 compatibilmente con l'NPSHR

y = Immersione minima con motore senza mantello in funzione intermittente S3 compatibilmente con l'NPSHR

(*) Vedere pagina flange.

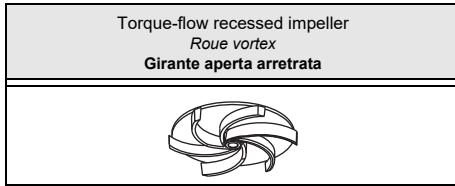

Type Type Tipo	KCW100N...+...22N3	KCW100N...+...22X3
Thermal probes Sondes thermiques Sonda termiche	Yes Oui Sì	Yes Oui Sì
Conductivity probe Sonde de conductivité Sonda di conduttività	Yes Oui Sì	Yes Oui Sì

Version cable (1) Version câble (1) Cavo Versione (1)		
Electric pump type Electropompe type Elettropompa tipo	Power supply Alimentation Alimentazione	Auxiliary Auxiliaire Ausiliario
KCW100NL+026022N3	2x(4x10)x10	1x(4x1,5)x10
KCW100NI+026022N3	2x(4x10)x10	1x(4x1,5)x10
KCW100NH+035022N3	2x(4x10)x10	1x(4x1,5)x10
KCW100NG+035022N3	2x(4x10)x10	1x(4x1,5)x10
KCW100NF+035022N3	2x(4x10)x10	1x(4x1,5)x10
KCW100NE+035022N3	2x(4x10)x10	1x(4x1,5)x10
KCW100ND+035022N3	2x(4x10)x10	1x(4x1,5)x10

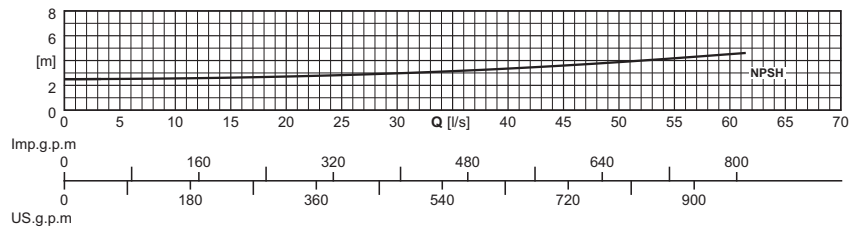
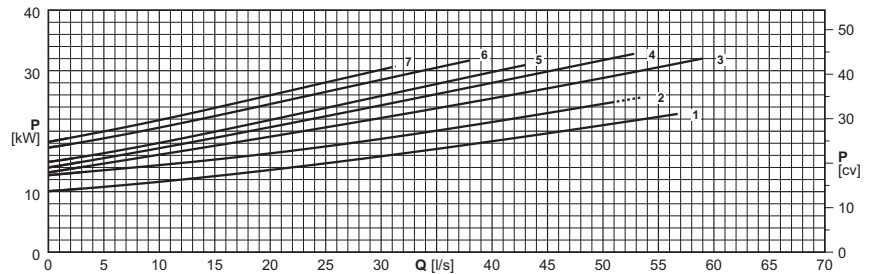
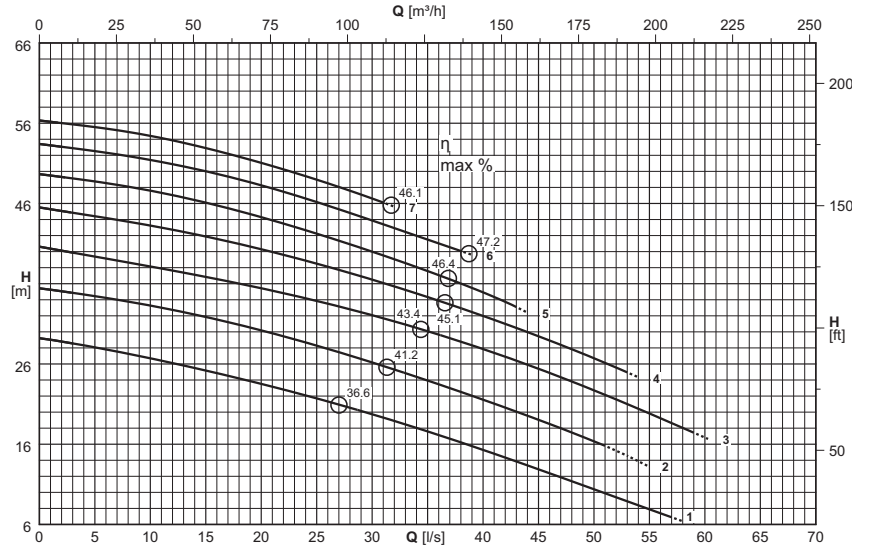

(1) = n°. of cables x (n°. of wires each cable x size [mm²]) x cable length [m] - Câble NSSHOU-J

Cable length exceeding 10 m on request

(1) = n°. câbles x (n°. conducteurs câble x section [mm²]) x longueur câble [m] - Câble NSSHOU-J

Sur demande longueur de câble supérieure à 10 m

(1) = n°. cavi x (n°. conduttori per cavo x sezione [mm²]) x lunghezza cavo [m] - Cavo NSSHOU-J

Lunghezza cavo superiore a 10 m - su richiesta

Electric pump type Electropompe type Elettropompa tipo	Curve Courbe Curva	Motor power Puiss. moteur Potenza motore	Capacity Débit Portata																		
			[l/s]	0	2	4	6	8	10	15	20	25	30	35	40	45	50	55	60		
			P ₂	[m ³ /h]	0	7,2	14,4	21,6	28,8	36	54	72	90	108	126	144	162	180	198	216	
			(N°)	[kW]	Head Hauteur Prevalenza																
			[m]	29,2	28,8	28,3	27,8	27,3	26,7	25,2	23,5	21,7	19,7	17,6	15,3	12,9	10,4	7,9			
KCW100NL+026022N3	1	26	[m]	29,2	28,8	28,3	27,8	27,3	26,7	25,2	23,5	21,7	19,7	17,6	15,3	12,9	10,4	7,9			
KCW100NI+026022N3	2	26	[m]	35,4	35	34,7	34,2	33,8	33,3	31,8	30,2	28,3	26,2	23,9	21,5	19	16,3				
KCW100NH+035022N3	3	35	[m]	40,6	40,1	39,6	39,1	38,6	38,1	36,8	35,4	33,8	32,1	30,1	27,8	25,4	22,7	19,8	16,8		
KCW100NG+035022N3	4	35	[m]	45,5	45,1	44,6	44,2	43,7	43,2	41,9	40,3	38,5	36,5	34,3	32	29,4	26,7				
KCW100NF+035022N3	5	35	[m]	49,7	49,3	48,9	48,5	48,1	47,6	46,1	44,3	42,2	40	37,6	34,9						
KCW100NE+035022N3	6	35	[m]	53,4	53,1	52,7	52,3	51,9	51,4	50	48,3	46,2	43,9	41,5							
KCW100ND+035022N3	7	35	[m]	56,3	56	55,7	55,3	54,9	54,4	52,9	51,1	49	46,6								
NPSH _R			[m]			2,5	2,5	2,5	2,6	2,6	2,7	2,8	3	3,1	3,4	3,6	3,9	4,2	4,5		

P₂ = Power rated by the motor

Performance tolerance as per:
UNI/ISO 9906 Grade 3B

For motor performances specification see page "motor features"

For the accessories specification see page "Accessories"

The impellers will be trimmed to meet the duty point

P₂ = Puissance restituée par le moteur

Tolérances sur les performances selon normes:
UNI/ISO 9906 Niveau 3B

Pour caractéristiques techniques moteurs voir page "Caractéristiques des moteurs"

Pour les accessoires voir page "Accessories"

Le point de fonctionnement désiré peut être obtenu par rognage de roue

P₂ = Potenza resa dal motore

Tolleranze sulle prestazioni secondo norme:
UNI/ISO 9906 Grado 3B

Per caratteristiche motori vedere pagina "caratteristiche motori"

Per accessori vedere pagina accessori

Le giranti vengono tornite in modo da ottenere il punto di lavoro richiesto

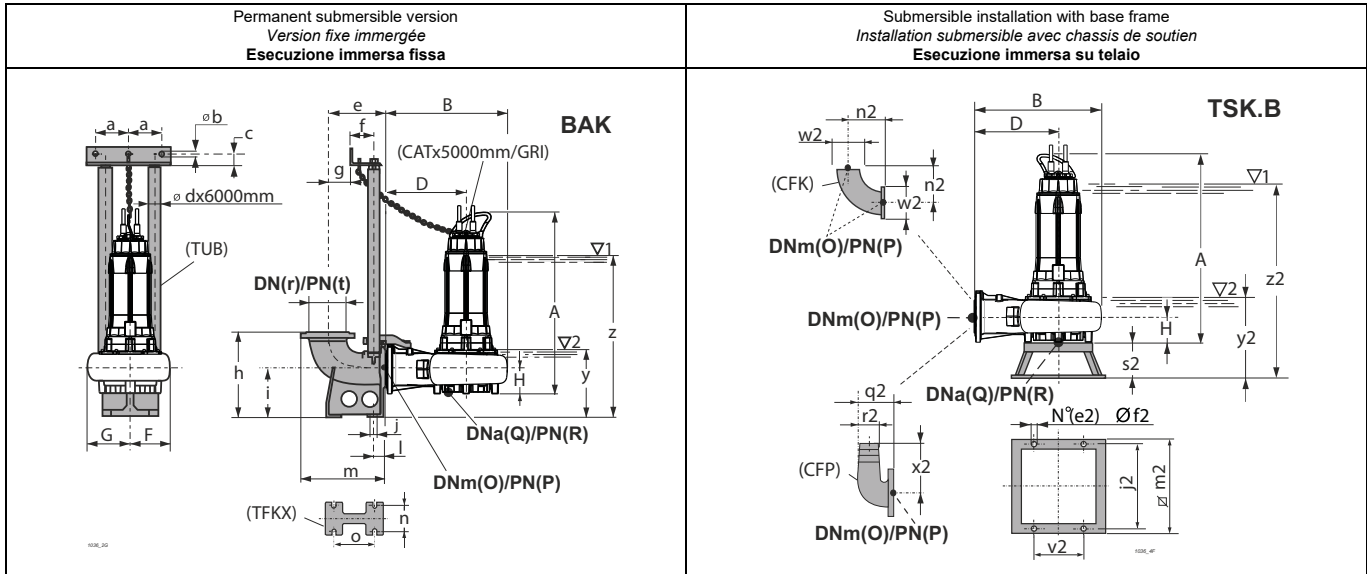

For fixed installation in a dry chamber - vertical (R)
Pour installation fixe en fosse sèche - verticale (R)
Esecuzione per camera asciutta - verticale (R)

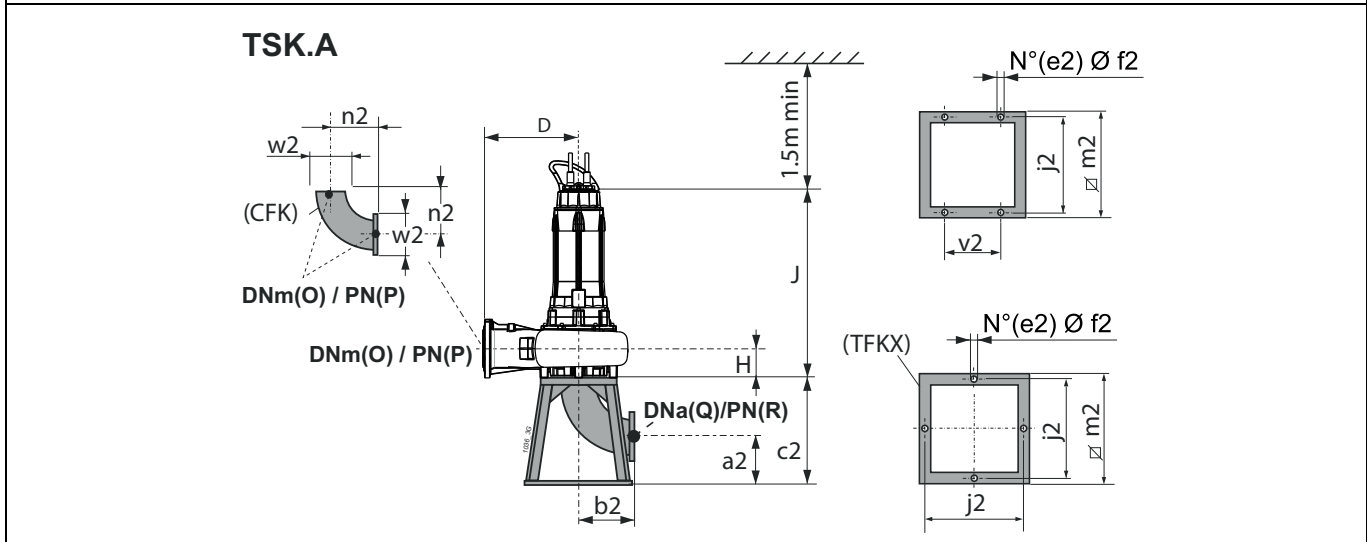

Type Type Tipo	Free passage Passage libre Passaggio Libero	Weight Poids Peso	A	B	D	F	G	H	J	O	P	Q	R	Accessories Accessoires Accessori					
			[mm]	[kg]	[mm]											BAK.	TSK.A	TSK.B/N	
KCW100NL+026022N3	Ø 80	330,73	1183	553	335	200	200	110	1028,5	100	16	100	16	G 2"	100	100			
KCW100NI+026022N3	Ø 80	330,93	1183	553	335	200	200	110	1028,5	100	16	100	16	G 2"	100	100			
KCW100NH+035022N3	Ø 80	354,13	1183	553	335	200	200	110	1028,5	100	16	100	16	G 2"	100	100			
KCW100NG+035022N3	Ø 80	354,23	1183	553	335	200	200	110	1028,5	100	16	100	16	G 2"	100	100			
KCW100NF+035022N3	Ø 80	354,33	1183	553	335	200	200	110	1028,5	100	16	100	16	G 2"	100	100			
KCW100NE+035022N3	Ø 80	349,13	1183	553	335	200	200	110	1028,5	100	16	100	16	G 2"	100	100			
KCW100ND+035022N3	Ø 80	354,6	1183	553	335	200	200	110	1028,5	100	16	100	16	G 2"	100	100			
BAK.	a	b	c	d	e	f	g	h	i	j	l	m	n	o	r	t	y	z	
BAKG 2"	130	12,5	35	2"	228	102	48	350	200	18	49	338	135	186	100	16	367	988	
TSK.A	a2	b2	c2	e2	f2	j2	m2	n2	v2	w2									
TSK100A	135	204	340	4	22	600	650	204	-	220									
TSK.B/N	e2	f2	j2	m2	n2	q2	r2	s2	v2	w2	x2	y2	z2						
TSK100B/N	4	14	600	650	204	215	100	180	350	220	273	457	1078						

(3) z = Minimum submergence depth for motor without casing with continuous duty S1 (NPSHR permitting)

y = Minimum submergence depth for motor without casing with intermittent duty S3 (NPSHR permitting)

(3) z = Immersion minimum pour moteur sans chemise en service continu S1 (compatible avec le NPSHR)

y = Immersion minimum pour moteur sans chemise en service intermittent S3 (compatible avec le NPSHR)

(3) z = Immersion minima per motore senza mantello in funzione continuo S1 compatibilmente con l'NPSHR

y = Immersione minima con motore senza mantello in funzione intermittente S3 compatibilmente con l'NPSHR

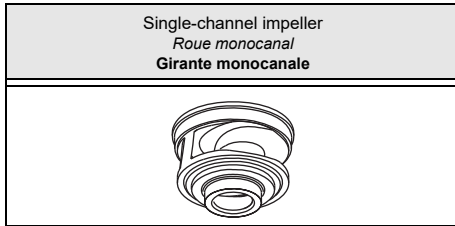

Type Type Tipo	KCM100N...+...22N3	KCM100N...+...22X3
Thermal probes Sondes thermiques Sonda termiche	Yes Oui Sì	Yes Oui Sì
Conductivity probe Sonde de conductivité Sonda di conduttività	Yes Oui Sì	Yes Oui Sì

Version cable (1) Version câble (1) Cavo Versione (1)		
Electric pump type Electropompe type Elettropompa tipo	Power supply Alimentazione	Auxiliary Auxiliaire Ausiliario
KCM100NG+026022N3	2x(4x10)x10	1x(4x1,5)x10
KCM100NF+026022N3	2x(4x10)x10	1x(4x1,5)x10
KCM100NE+026022N3	2x(4x10)x10	1x(4x1,5)x10
KCM100ND+026022N3	2x(4x10)x10	1x(4x1,5)x10
KCM100NC+026022N3	2x(4x10)x10	1x(4x1,5)x10
KCM100ND+035022N3	2x(4x10)x10	1x(4x1,5)x10
KCM100NC+035022N3	2x(4x10)x10	1x(4x1,5)x10
KCM100NB+035022N3	2x(4x10)x10	1x(4x1,5)x10
KCM100NA+035022N3	2x(4x10)x10	1x(4x1,5)x10

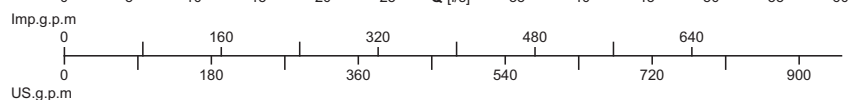
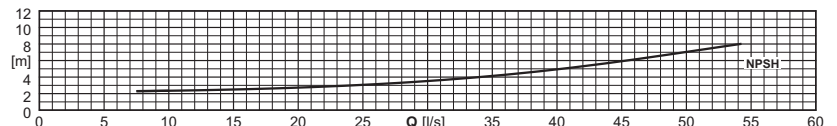
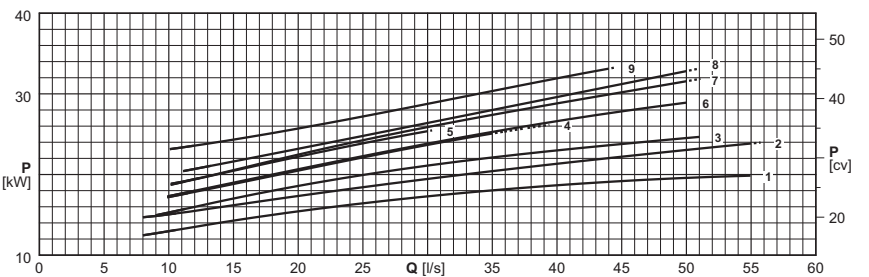
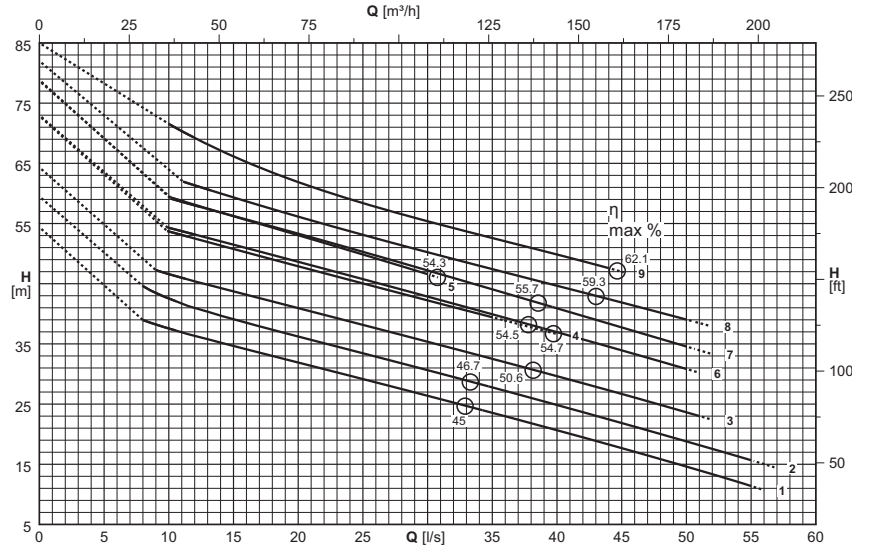

(1) = n°. of cables x (n°. of wires each cable x size [mm²]) x cable length [m] - Câble NSSHOU-J

Cable length exceeding 10 m on request

(1) = n°. câbles x (n°. conducteurs câble x section [mm²]) x longueur câble [m] - Câble NSSHOU-J

Sur demande longueur de câble supérieure à 10 m

(1) = n°. cavi x (n°. conduttori per cavo x sezione [mm²]) x lunghezza cavo [m] - Cavo NSSHOU-J

Lunghezza cavo superiore a 10 m - su richiesta

Electric pump type Electropompe type Elettropompa tipo	Curve Courbe Curva	Motor power Puiss. moteur Potenza motore	Capacity Débit Portata																
			[l/s]	0	8	10	15	20	25	30	35	40	45	50	55	56			
	(N°)	[kW]	[m ³ /h]	0	28,8	36	54	72	90	108	126	144	162	180	198	201,6			
				Head Hauteur Prevalenza															
			[m]	49,4	39	37,6	34,7	31,9	29,2	26,4	23,5	20,7	17,7	14,6	11,4	10,7			
KCM100NG+026022N3	1	26	[m]	49,4	39	37,6	34,7	31,9	29,2	26,4	23,5	20,7	17,7	14,6	11,4	10,7			
KCM100NF+026022N3	2	26	[m]	54,5	44,6	42,6	39,1	36,2	33,4	30,6	27,8	24,8	21,8	18,8	15,7	15			
KCM100NE+026022N3	3	26	[m]	59,3		46,6	43,7	40,9	38,2	35,4	32,5	29,6	26,7	23,6					
KCM100ND+026022N3	4	26	[m]	67,9		53,7	50,8	47,9	45	42,2	39,4	36,6							
KCM100NC+026022N3	5	26	[m]	73,7			56,2	53,1	49,9	46,6									
KCM100ND+035022N3	6	35	[m]	68		54,3	51,5	48,6	45,8	42,9	39,9	36,9	33,9	30,8					
KCM100NC+035022N3	7	35	[m]	73,9			56,3	53,3	50,3	47,2	44,1	40,9	37,7	34,6					
KCM100NB+035022N3	8	35	[m]	77			59,3	56,1	53,1	50,2	47,4	44,7	41,9	39					
KCM100NA+035022N3	9	35	[m]	80,1			66,2	61,9	58,4	55,4	52,6	49,9	47						
NPSH _R			[m]		2,3	2,3	2,5	2,7	3,1	3,5	4,1	4,9	5,9	7	8,2				

P₂ = Power rated by the motor

Performance tolerance as per: UNI/ISO 9906 Grade 3B

For motor performances specification see page "motor features"

For the accessories specification see page "Accessories"

P₂ = Puissance restituée par le moteur

Tolérances sur les performances selon normes: UNI/ISO 9906 Niveau 3B

Pour caractéristiques techniques moteurs voir page "Caractéristiques des moteurs"

Pour les accessoires voir page "Accessories"

P₂ = Potenza resa dal motore

Tolleranze sulle prestazioni secondo norme: UNI/ISO 9906 Grado 3B

Per caratteristiche motori vedere pagina "caratteristiche motori"

Per accessori vedere pagina accessori

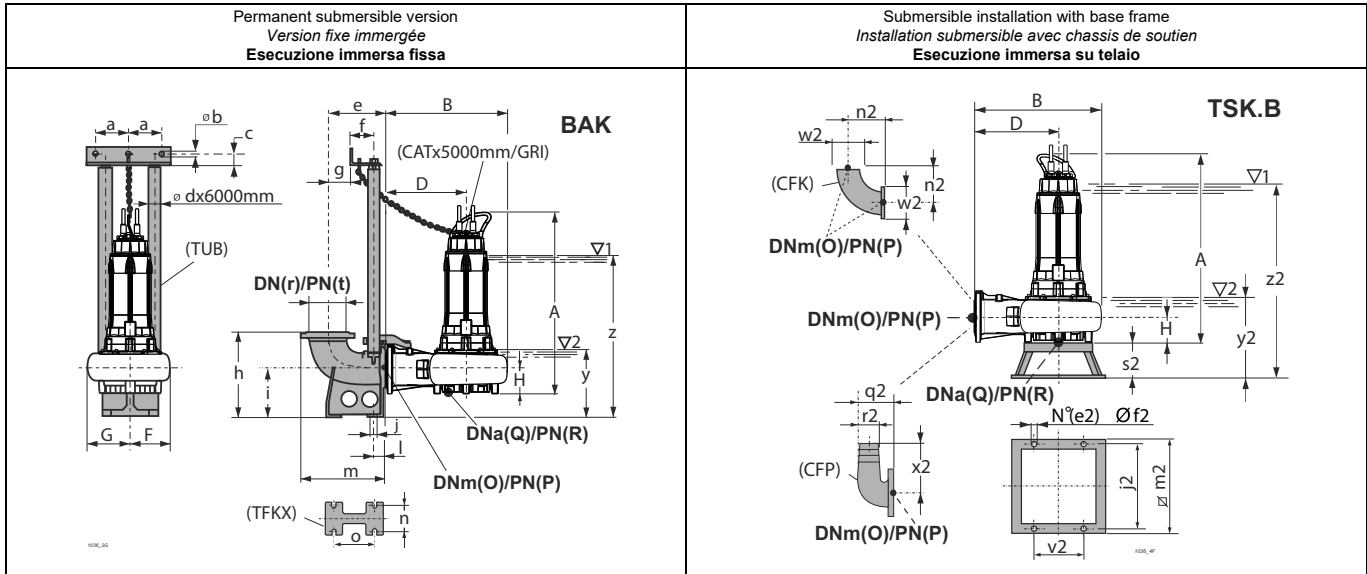

For fixed installation in a dry chamber - vertical (R)
Pour installation fixe en fosse sèche - verticale (R)
Esecuzione per camera asciutta - verticale (R)

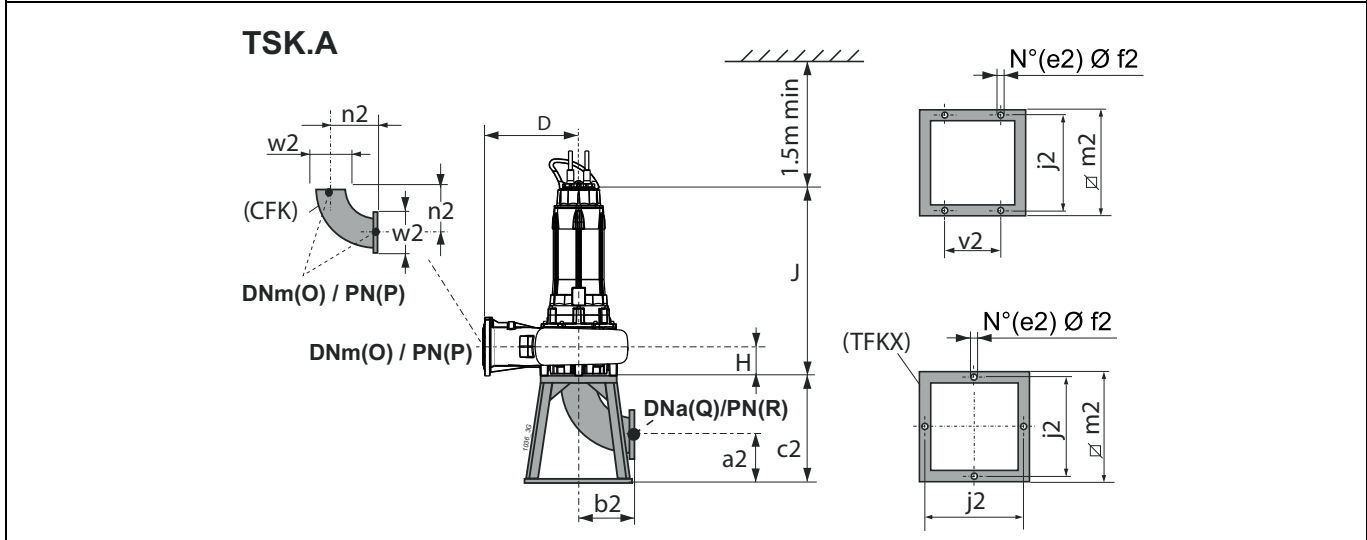

Type Type Tipo	Free passage Passage Passaggio Libero	Weight Poids Peso	A	B	D	F	G	H	J	O	P	Q	R	Accessories Accessoires Accessori					
			[mm]	[kg]	[mm]											BAK.	TSK.A	TSK.B/N	
KCM100NG+026022N3	Ø 80	342,29	1183	553	335	200	200	110	1028,5	100	16	100	16	G 2"	100	100			
KCM100NF+026022N3	Ø 80	342,43	1183	553	335	200	200	110	1028,5	100	16	100	16	G 2"	100	100			
KCM100NE+026022N3	Ø 80	342,93	1183	553	335	200	200	110	1028,5	100	16	100	16	G 2"	100	100			
KCM100ND+026022N3	Ø 80	343,67	1183	553	335	200	200	110	1028,5	100	16	100	16	G 2"	100	100			
KCM100NC+026022N3	Ø 80	343,93	1183	553	335	200	200	110	1028,5	100	16	100	16	G 2"	100	100			
KCM100ND+035022N3	Ø 80	366,87	1183	553	335	200	200	110	1028,5	100	16	100	16	G 2"	100	100			
KCM100NC+035022N3	Ø 80	367,13	1183	553	335	200	200	110	1028,5	100	16	100	16	G 2"	100	100			
KCM100NB+035022N3	Ø 80	367,43	1183	553	335	200	200	110	1028,5	100	16	100	16	G 2"	100	100			
KCM100NA+035022N3	Ø 80	368,13	1183	553	335	200	200	110	1028,5	100	16	100	16	G 2"	100	100			
BAK.	a	b	c	d	e	f	g	h	i	j	l	m	n	o	r	t	y	z	
BAKG 2"	130	12,5	35	2"	228	102	48	350	200	18	49	338	135	186	100	16	367	988	
TSK.A	a2	b2	c2	e2	f2	j2	m2	n2	v2	w2									
TSK100A	135	204	340	4	22	600	650	204	204	-	220								
TSK.B/N	e2	f2	j2	m2	n2	q2	r2	s2	v2	w2	x2	y2	z2						
TSK100B/N	4	14	600	650	204	215	100	180	350	220	273	457	1078						

(3) z = Minimum submergence depth for motor without casing with continuous duty S1 (NPSHR permitting)

(3) z = Immersion minimum pour moteur sans chemise en service continu S1 (compatible avec le NPSHR)

(3) z = Immersion minima per motore senza mantello in funzione continuo S1 compatibilmente con l'NPSHR

y = Minimum submergence depth for motor without casing with intermittent duty S3 (NPSHR permitting)

y = Immersion minimum pour moteur sans chemise en service intermittent S3 (compatible avec le NPSHR)

y = Immersion minima con motore senza mantello in funzione intermittente S3 compatibilmente con l'NPSHR

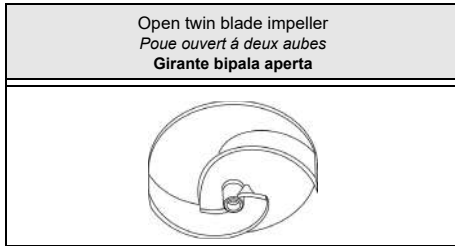

Type Type Tipo	KCA100N.+...22N3	KCA100N.+...22X3
Thermal probes Sondes thermiques Sonde termiche	Yes Oui Sì	Yes Oui Sì
Conductivity probe Sonde de conductivité Sonda di conduttività	Yes Oui Sì	Yes Oui Sì

Version cable (1) Version câble (1) Cavo Versione (1)		
Electric pump type Electropompe type Elettropompa tipo	Power supply Alimentation Alimentazione	Auxiliary Auxiliaire Ausiliario
KCA100NP+026022N3	2x(4x10)x10	1x(4x1,5)x10
KCA100NL+026022N3	2x(4x10)x10	1x(4x1,5)x10
KCA100NI+026022N3	2x(4x10)x10	1x(4x1,5)x10
KCA100NG+026022N3	2x(4x10)x10	1x(4x1,5)x10
KCA100ND+026022N3	2x(4x10)x10	1x(4x1,5)x10
KCA100ND+035022N3	2x(4x10)x10	1x(4x1,5)x10
KCA100NA+035022N3	2x(4x10)x10	1x(4x1,5)x10

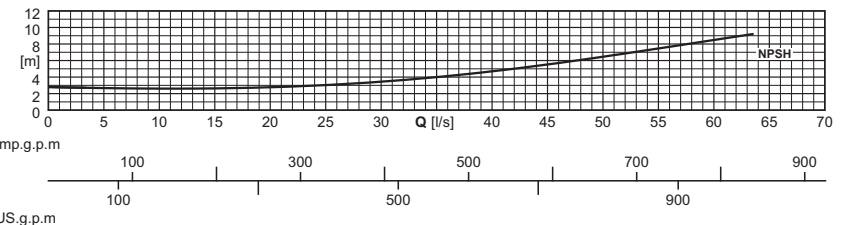
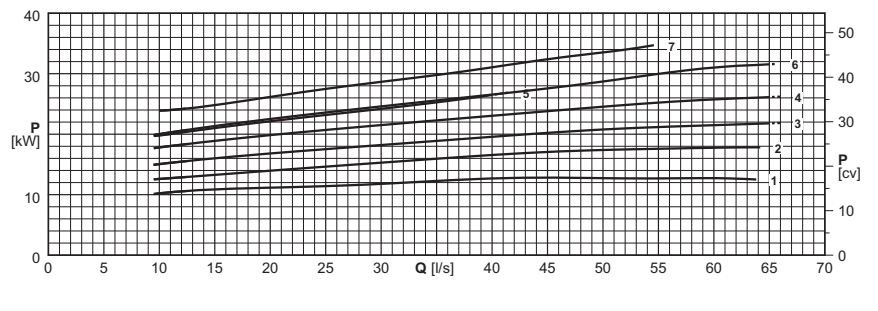
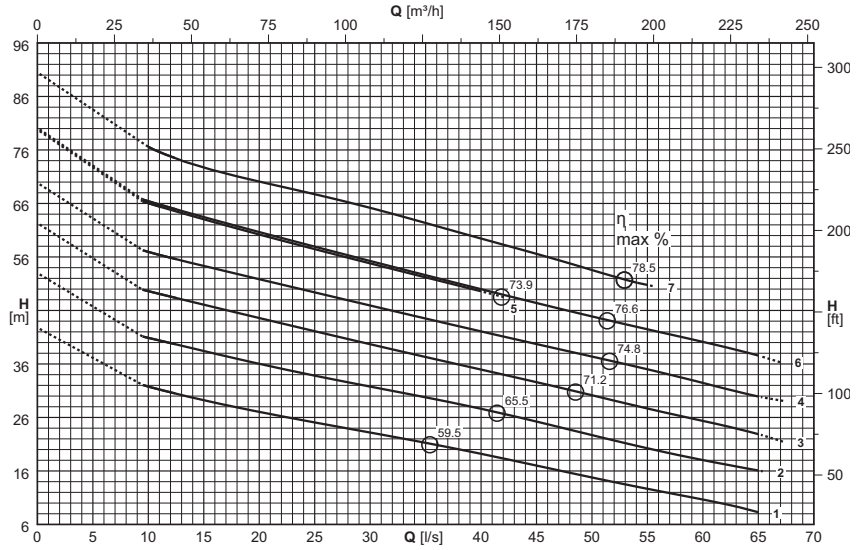

(1) = n°. of cables x (n°. of wires each cable x size [mm²]) x cable length [m] - Câble NSSHÖU-J
Cable length exceeding 10 m on request

(1) = n°. câbles x (n°. conducteurs câble x section [mm²]) x longueur câble [m] - Câble NSSHÖU-J
Sur demande longueur de câble supérieure à 10 m

(1) = n°. cavi x (n°. conduttori per cavo x sezione [mm²]) x lunghezza cavo [m] - Cavo NSSHÖU-J
Lunghezza cavo superiore a 10 m - su richiesta

Electric pump type Electropompe type Elettropompa tipo	Curve Courbe Curva	Motor power Puiss. moteur Potenza motore	Capacity Débit Portata																	
			[l/s]	0	10	15	20	25	30	35	40	45	50	55	60	65	67			
	(N°)	[kW]	[m ³ /h]	0	36	54	72	90	108	126	144	162	180	198	216	234	241,2			
				Head Hauteur Prevalenza																
KCA100NP+026022N3	1	26	[m]	36,8	31,8	29,2	27,1	25,1	23,2	21,3	19,2	17	14,8	12,7	10,6	8,3				
KCA100NL+026022N3	2	26	[m]	47	40,9	38,4	36	33,8	31,8	29,8	27,6	25,2	22,7	20,3	18	16,1				
KCA100NI+026022N3	3	26	[m]	56,3	49,6	47,1	44,6	42,1	39,7	37,3	35	32,6	30,1	27,7	25,4	22,8	21,6			
KCA100NG+026022N3	4	26	[m]	63,9	57	54,3	51,8	49,4	46,9	44,5	42,1	39,7	37,4	35	32,4	30	29,2			
KCA100ND+026022N3	5	26	[m]	73,8	66,1	63	60,2	57,5	54,8	52,2	49,6									
KCA100ND+035022N3	6	35	[m]	74,1	66,4	63,5	60,7	57,9	55,3	52,6	50	47,4	44,9	42,5	40,1	37,5				
KCA100NA+035022N3	7	35	[m]	84,5	76,6	72,7	70,1	67,7	65,2	62,3	59,4	56,6	53,6	50,8						
NPSH _R			[m]		2,6	2,7	2,8	3,1	3,5	4	4,7	5,5	6,5	7,5	8,5	9,5				

P₂ = Power rated by the motor
Performance tolerance as per:
UNI/ISO 9906 Grade 3B
For motor performances specification see page "motor features"

P₂ = Puissance restituée par le moteur
Tolérances sur les performances selon normes:
UNI/ISO 9906 Niveau 3B
Pour caractéristiques techniques moteurs voir page "Caractéristiques des moteurs"
Pour les accessoires voir page "Accessories"
Le point de fonctionnement désiré peut être obtenu par rognage de roue

P₂ = Potenza resa dal motore
Tolleranze sulle prestazioni secondo norme:
UNI/ISO 9906 Grado 3B
Per caratteristiche motori vedere pagina "caratteristiche motori"
Per accessori vedere pagina accessori
Le giranti vengono tornite in modo da ottenere il punto di lavoro richiesto

For the accessories specification see page "Accessories"
The impellers will be trimmed to meet the duty point

For the accessories specification see page "Accessories"
The impellers will be trimmed to meet the duty point

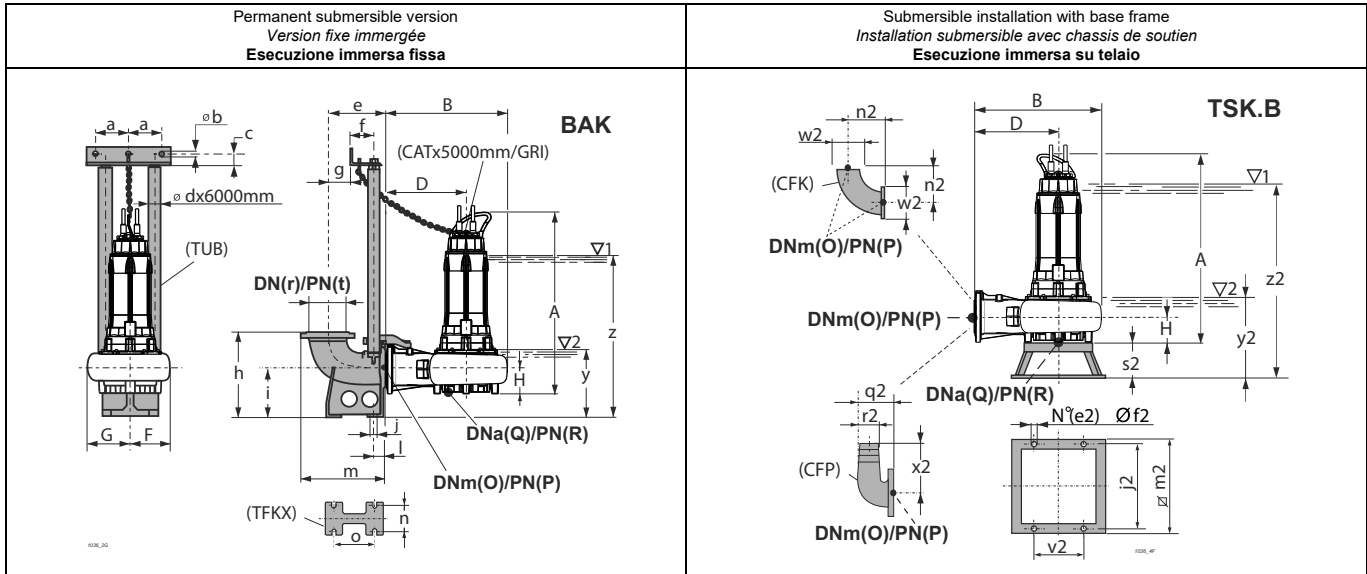

For fixed installation in a dry chamber - vertical (R)
Pour installation fixe en fosse sèche - verticale (R)
Esecuzione per camera asciutta - verticale (R)

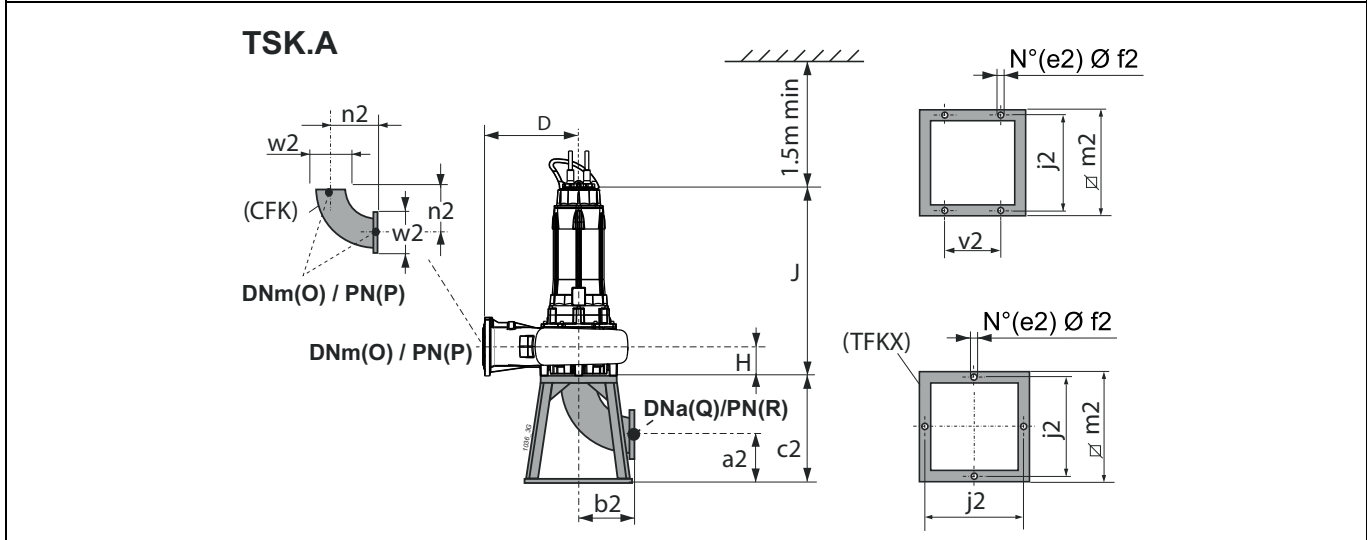

Type Type Tipo	Free passage Passage libre Passaggio Libero	Weight Poids Peso	A	B	D	F	G	H	J	O	P	Q	R	Accessories Accessoires Accessori					
			[mm]	[kg]	[mm]											BAK.	TSK.A	TSK.B	
KCA100NP+026022N3	---	318,69	1172,5	564,7	345	202,2	218	112	1018	100	16	100	16	G 2"	I	M			
KCA100NL+026022N3	---	318,83	1172,5	564,7	345	202,2	218	112	1018	100	16	100	16	G 2"	I	M			
KCA100NI+026022N3	---	318,94	1172,5	564,7	345	202,2	218	112	1018	100	16	100	16	G 2"	I	M			
KCA100NG+026022N3	---	319,08	1172,5	564,7	345	202,2	218	112	1018	100	16	100	16	G 2"	I	M			
KCA100ND+026022N3	---	319,22	1172,5	564,7	345	202,2	218	112	1018	100	16	100	16	G 2"	I	M			
KCA100ND+035022N3	---	346,12	1172,5	564,7	345	202,2	218	112	1018	100	16	100	16	G 2"	I	M			
KCA100NA+035022N3	---	346,28	1172,5	564,7	345	202,2	218	112	1018	100	16	100	16	G 2"	I	M			
BAK.	a	b	c	d	e	f	g	h	i	j	l	m	n	o	r	t	y	z	
BAKG 2"	130	12,5	35	2"	228	102	48	350	200	18	49	338	135	186	100	16	354,5	975,5	
TSK.A	a2	b2	c2	e2	f2	j2	m2	n2	v2	w2									
TSKIA	205	395	600	4	22	600	650	204	-	220									
TSK.B	e2	f2	j2	m2	n2	q2	r2	s2	v2	w2	x2	y2	z2						
TSKMB	4	14	600	650	204	215	100	220	350	220	273	486,5	1107,5						

(3) z = Minimum submergence depth for motor without casing with continuous duty S1 (NPSHR permitting)

y = Minimum submergence depth for motor without casing with intermittent duty S3 (NPSHR permitting)

(3) z = Immersion minimum pour moteur sans chemise en service continu S1 (compatible avec le NPSHR)

y = Immersion minimum pour moteur sans chemise en service intermittent S3 (compatible avec le NPSHR)

(3) z = Immersion minima per motore senza mantello in funzione continuo S1 compatibilmente con l'NPSHR

y = Immersione minima con motore senza mantello in funzione intermittente S3 compatibilmente con l'NPSHR

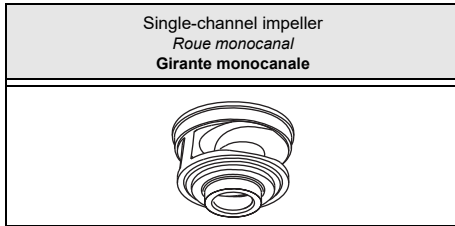

Type <i>Type</i> Tipo	KCM150N...+...42N3	KCM150N...+...42X3
Thermal probes <i>Sondes</i> <i>thermiques</i> Sonda termiche	Yes <i>Oui</i> Sì	Yes <i>Oui</i> Sì
Conductivity probe <i>Sonde de</i> <i>conductivité</i> Sonda di conduttività	Yes <i>Oui</i> Sì	Yes <i>Oui</i> Sì

Version cable (1)
Version câble (1)
Cavo Versione (1)

Electric pump type <i>Electropompe type</i> Elettropompa tipo	Power supply <i>Alimentation</i> Alimentazione	Auxiliary <i>Auxiliaire</i> Ausiliario
KCM150NL+016542N3	2x(4x6)x10	1x(4x1,5)x10
KCM150NG+019342N3	2x(4x10)x10	1x(4x1,5)x10
KCM150ND+021042N3	2x(4x10)x10	1x(4x1,5)x10
KCM150NA+026042N3	2x(4x10)x10	1x(4x1,5)x10

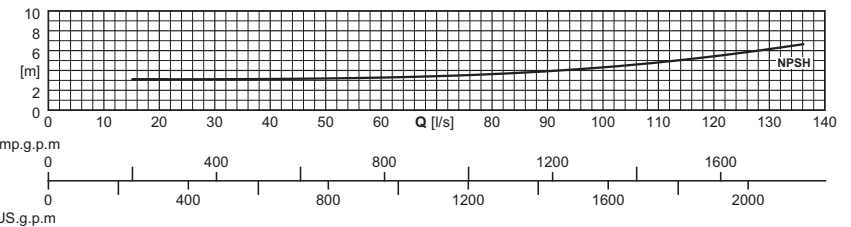
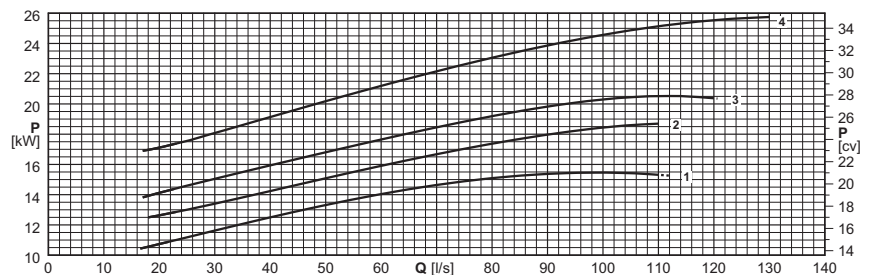
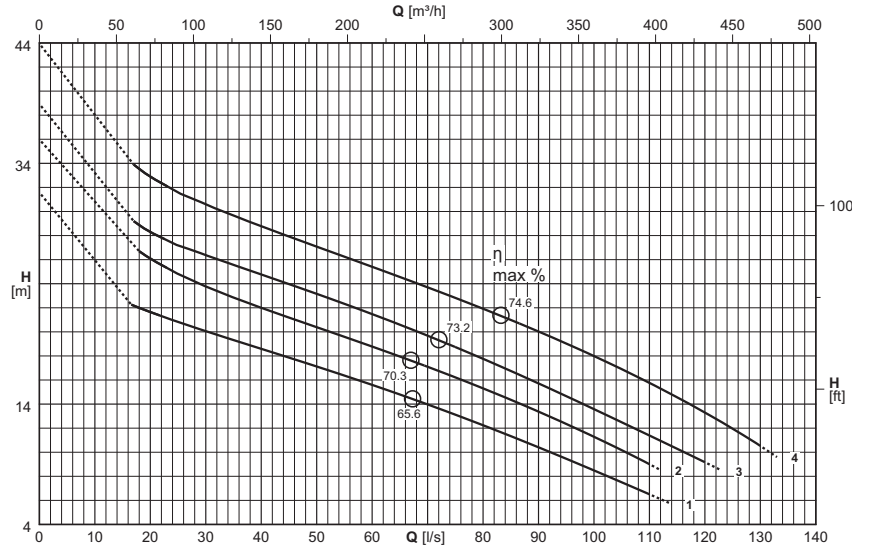

(1) = n°. of cables x (n°. of wires each cable x size [mm²]) x cable length [m] - Cable NSSHÖU-J

Cable length exceeding 10 m on request

(1) = n°. câbles x (n°. conducteurs câble x section [mm²]) x longueur câble [m] - Câble NSSHÖU-J

Sur demande longueur de câble supérieure à 10 m

(1) = n°. cavi x (n°. conduttori per cavo x sezione [mm²]) x lunghezza cavo [m] - Cavo NSSHÖU-J

Lunghezza cavo superiore a 10 m - su richiesta

Electric pump type <i>Electropompe type</i> Elettropompa tipo	Curve <i>Courbe</i> Curva	Motor power <i>Puiss. moteur</i> Potenza motore	Capacity <i>Debit</i> Portata																
			[l/s]	0	20	25	30	35	40	45	50	60	70	80	90	100	125	133	
	(N°)	[kW]	[m³/h]	0	72	90	108	126	144	162	180	216	252	288	324	360	450	478,8	
			Head <i>Hauteur</i> Prevalenza																
			[m]	27,6	21,7	20,8	20,1	19,3	18,6	17,9	17,1	15,6	14	12,2	10,4	8,5			
KCM150NL+016542N3	1	16,5	[m]	27,6	21,7	20,8	20,1	19,3	18,6	17,9	17,1	15,6	14	12,2	10,4	8,5			
KCM150NG+019342N3	2	19,3	[m]	32	26,1	24,9	23,8	22,9	22	21,2	20,4	18,8	17,1	15,3	13,4	11,3			
KCM150ND+021042N3	3	21	[m]	34,9	28,4	27,3	26,4	25,6	24,8	24	23,2	21,5	19,7	17,8	15,7	13,6			
KCM150NA+026042N3	4	26	[m]	39,9	33	31,7	30,6	29,7	28,8	27,9	27,1	25,4	23,7	21,9	20	18	11,9	9,6	
NPSH _R			[m]		3,1	3,1	3,1	3,1	3,1	3,2	3,2	3,3	3,4	3,6	3,9	4,3	5,8	6,4	

P₂ = Power rated by the motor

Performance tolerance as per: UNI/ISO 9906 Grade 3B

For motor performances specification see page "motor features"

For the accessories specification see page "Accessories"

P₂ = Puissance restituée par le moteur

Tolérances sur les performances selon normes: UNI/ISO 9906 Niveau 3B

Pour caractéristiques techniques moteurs voir page "Caractéristiques des moteurs"

Pour les accessoires voir page "Accessories"

P₂ = Potenza resa dal motore

Tolleranze sulle prestazioni secondo norme: UNI/ISO 9906 Grado 3B

Per caratteristiche motori vedere pagina "caratteristiche motori"

Per accessori vedere pagina accessori

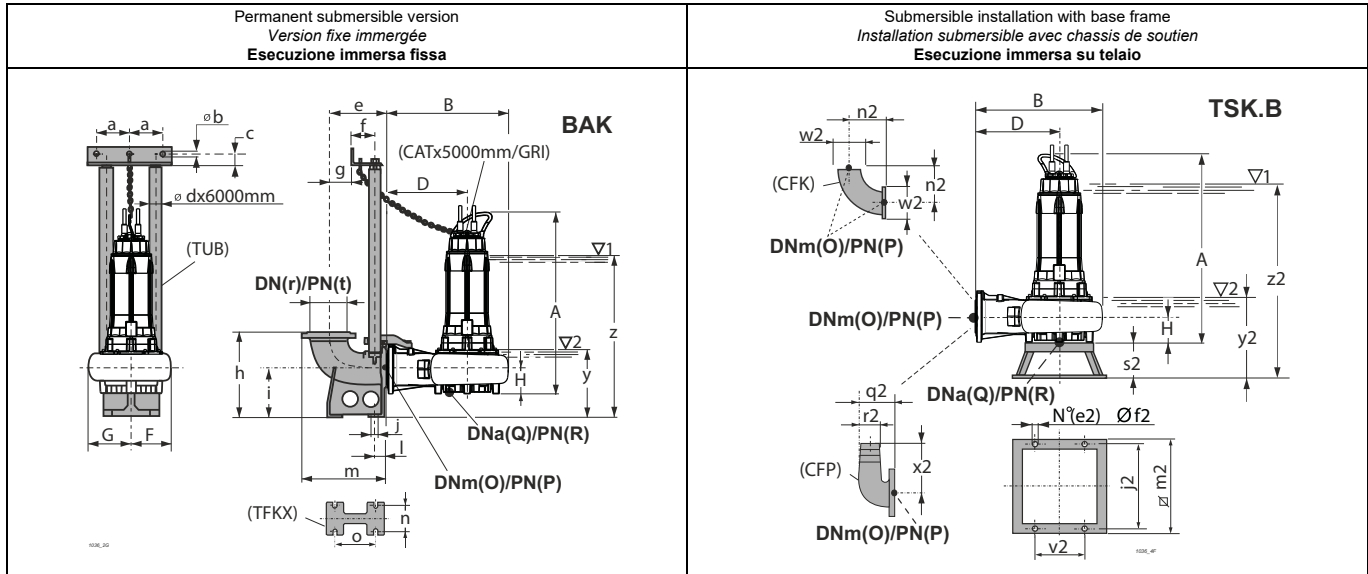

For fixed installation in a dry chamber - vertical (R)
Pour installation fixe en fosse sèche - verticale (R)
Esecuzione per camera asciutta - verticale (R)

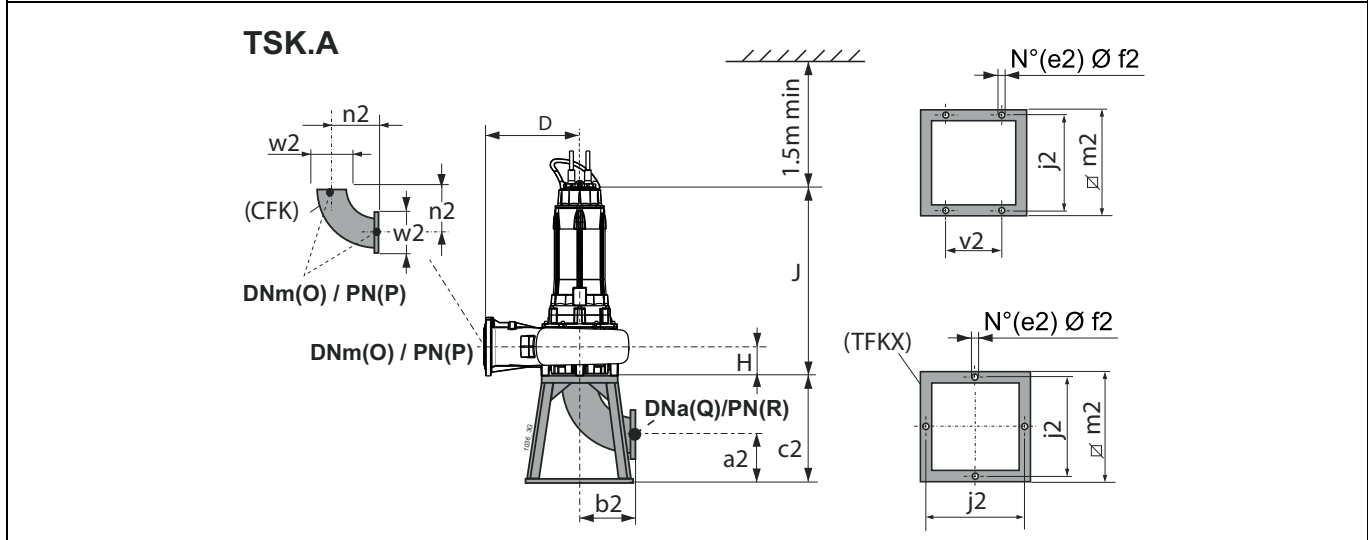

Type Type Tipo	Free passage Passage libre Passaggio Libero	Weight Poids Peso	[mm]												Accessories Accessoires Accessori			
			A	B	D	F	G	H	J	O	P	Q	R	BAK	TSK.A	TSK.B		
KCM150NL+016542N3	Ø 115	358,05	1240	658	405	229	278	160	1085,5	150	16	150	16	M/I 3"	I	M		
KCM150NG+019342N3	Ø 115	379,93	1240	658	405	229	278	160	1085,5	150	16	150	16	M/I 3"	I	M		
KCM150ND+021042N3	Ø 115	404,62	1240	658	405	229	278	160	1085,5	150	16	150	16	M/I 3"	I	M		
KCM150NA+026042N3	Ø 115	405,85	1240	658	405	229	278	160	1085,5	150	16	150	16	M/I 3"	I	M		
BAK.	a	b	c	d	e	f	g	h	i	j	l	m	n	o	r	t	y	z
BAKM/I 3"	157,5	12,5	35	3"	385	117	180	540	290	24	80	555	210	280	200	10	464	1085
TSK.A	a2	b2	c2	e2	f2	j2	m2	n2	v2	w2								
TSKIA	205	395	600	4	22	600	650	395	-	285								
TSK.B	e2	f2	j2	m2	n2	q2	r2	s2	v2	w2	x2	y2	z2					
TSKMB	4	14	600	650	395	315	150	220	350	285	380	554	1175					

(3) z = Minimum submergence depth for motor without casing with continuous duty S1 (NPSHR permitting)
y = Minimum submergence depth for motor without casing with intermittent duty S3 (NPSHR permitting)

(3) z = Immersion minimum pour moteur sans chemise en service continu S1 (compatible avec le NPSHR)
y = Immersion minimum pour moteur sans chemise en service intermittent S3 (compatible avec le NPSHR)

(3) z = Immersion minima per motore senza mantello in funzione continuo S1 compatibilmente con l'NPSHR
y = Immersione minima con motore senza mantello in funzione intermittente S3 compatibilmente con l'NPSHR

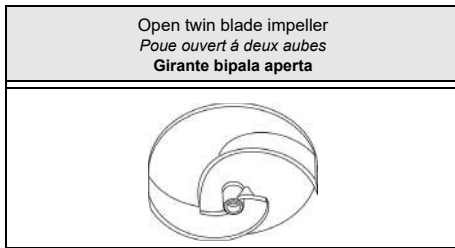

Type Type Tipo	KCA150N.+...42N3	KCA150N.+...42X3
Thermal probes Sondes thermiques Sonde termiche	Yes Oui Sì	Yes Oui Sì
Conductivity probe Sonde de conductivité Sonda di conduttività	Yes Oui Sì	Yes Oui Sì

Version cable (1) Version câble (1) Cavo Versione (1)		
Electric pump type Electropompe type Elettropompa tipo	Power supply Alimentation Alimentazione	Auxiliary Auxiliaire Ausiliario
KCA150NL+016542N3	2x(4x6)x10	1x(4x1,5)x10
KCA150NG+019342N3	2x(4x10)x10	1x(4x1,5)x10
KCA150ND+021042N3	2x(4x10)x10	1x(4x1,5)x10
KCA150NA+026042N3	2x(4x10)x10	1x(4x1,5)x10

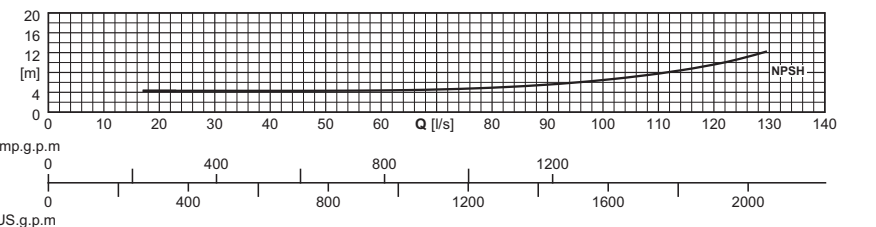
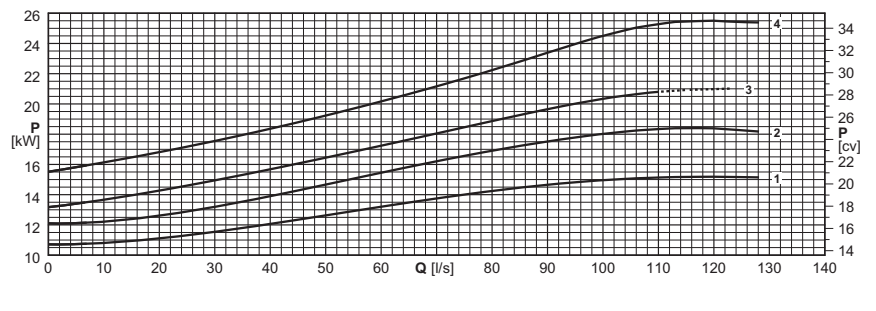
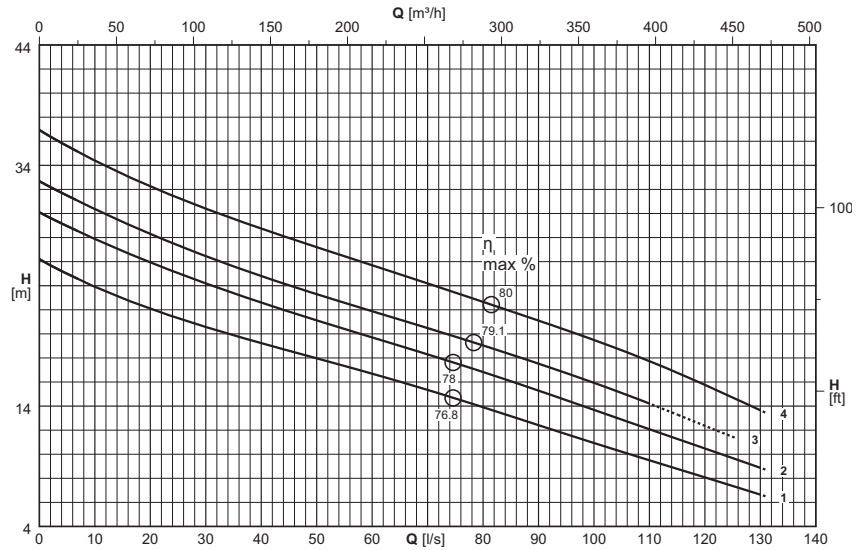

(1) = n°. of cables x (n°. of wires each cable x size [mm²]) x cable length [m] - Câble NSSHOU-J
Cable length exceeding 10 m on request

(1) = n°. câbles x (n°. conducteurs câble x section [mm²]) x longueur câble [m] - Câble NSSHOU-J
Sur demande longueur de câble supérieure à 10 m

(1) = n°. cavi x (n°. conduttori per cavo x sezione [mm²]) x lunghezza cavo [m] - Cavo NSSHOU-J
Lunghezza cavo superiore a 10 m - su richiesta

Electric pump type Electropompe type Elettropompa tipo	Curve Courbe Curva	Motor power Puiss. moteur Potenza motore	Capacity Débit Portata																		
			[l/s]	0	7	10	15	20	25	30	35	40	45	50	60	70	80	90	100	125	131
	(N°)	[kW]	[m ³ /h]	0	25,2	36	54	72	90	108	126	144	162	180	216	252	288	324	360	450	471,6
			Head Hauteur Prevalenza																		
KCA150NL+016542N3	1	16,5	[m]	26,2	24,6	24	23	22,1	21,3	20,6	19,9	19,2	18,6	18	16,7	15,3	13,9	12,4	10,9	7,4	6,5
KCA150NG+019342N3	2	19,3	[m]	30,1	28,5	27,9	26,9	25,9	25,1	24,2	23,4	22,6	21,9	21,1	19,7	18,3	16,8	15,3	13,7	9,7	8,7
KCA150ND+021042N3	3	21	[m]	32,7	31	30,4	29,3	28,3	27,4	26,5	25,6	24,8	24	23,3	21,9	20,5	19	17,5	15,9	11,5	
KCA150NA+026042N3	4	26	[m]	36,9	35,1	34,4	33,3	32,3	31,3	30,4	29,6	28,8	28	27,2	25,7	24,2	22,7	21,1	19,5	14,7	13,4
NPSH _R			[m]					4,3	4,3	4,3	4,3	4,3	4,3	4,3	4,4	4,6	4,9	5,6	6,5	10,9	13,1

P₂ = Power rated by the motor
Performance tolerance as per:
UNI/ISO 9906 Grade 3B

For motor performances specification see page "motor features"

For the accessories specification see page "Accessories"
The impellers will be trimmed to meet the duty point

P₂ = Puissance restituée par le moteur
Tolérances sur les performances selon normes:
UNI/ISO 9906 Niveau 3B

Pour caractéristiques techniques moteurs voir page "Caractéristiques des moteurs"

Pour les accessoires voir page "Accessories"
Le point de fonctionnement désiré peut être obtenu par rognage de roue

P₂ = Potenza resa dal motore
Tolleranze sulle prestazioni secondo norme:
UNI/ISO 9906 Grado 3B

Per caratteristiche motori vedere pagina "caratteristiche motori"

Per accessori vedere pagina accessori
Le giranti vengono tornite in modo da ottenere il punto di lavoro richiesto

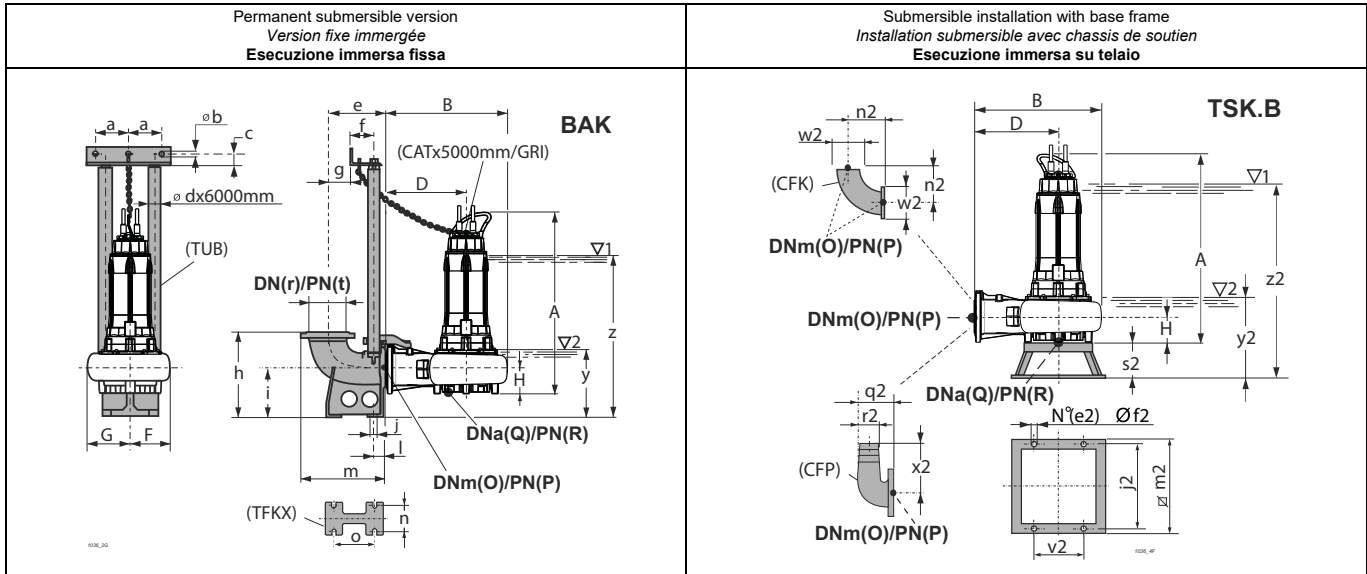

For fixed installation in a dry chamber - vertical (R)
Pour installation fixe en fosse sèche - verticale (R)
Esecuzione per camera asciutta - verticale (R)

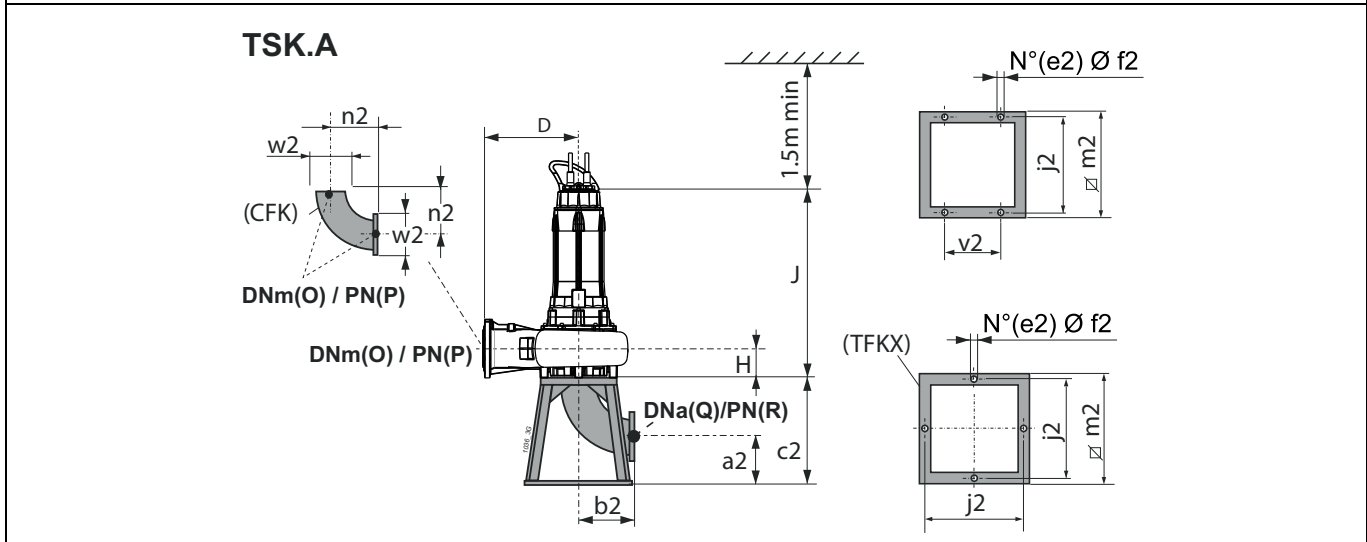

Type Type Tipo	Free passage Passage libre Passaggio Libero	Weight Poids Peso	A	B	D	F	G	H	J	O	P	Q	R	Accessories Accessoires Accessori		
			[mm]	[kg]	[mm]											BAK.
KCA150NL+016542N3	---	354,3	1208,5	662,3	405	228,8	286,2	138	1054	150	16	150	16(*)	M/I 3"	I	M
KCA150NG+019342N3	---	376,8	1208,5	662,3	405	228,8	286,2	138	1054	150	16	150	16(*)	M/I 3"	I	M
KCA150ND+021042N3	---	409,2	1208,5	662,3	405	228,8	286,2	138	1054	150	16	150	16(*)	M/I 3"	I	M
KCA150NA+026042N3	---	382,4	1208,5	662,3	405	228,8	286,2	138	1054	150	16	150	16(*)	M/I 3"	I	M

BAK.																		
a	b	c	d	e	f	g	h	i	j	l	m	n	o	r	t	y	z	
BAKM/I 3"	157,5	12,5	35	3"	385	117	180	540	290	24	80	555	210	280	200	10	454,5	1075,5
TSK.A																		
a2	b2	c2	e2	f2	j2	m2	n2	v2	w2									
TSKIA	205	395	600	4	22	600	650	395	-	285								
TSK.B																		
e2	f2	j2	m2	n2	q2	r2	s2	v2	w2	x2	y2	z2						
TSKMB	4	14	600	650	395	315	150	220	350	285	380	522,5	1143,5					

(3) z = Minimum submergence depth for motor without casing with continuous duty S1 (NPSHR permitting)

y = Minimum submergence depth for motor without casing with intermittent duty S3 (NPSHR permitting)

(*) Consult the flanges page.

(3) z = Immersion minimum pour moteur sans chemise en service continu S1 (compatible avec le NPSHR)

y = Immersion minimum pour moteur sans chemise en service intermittent S3 (compatible avec le NPSHR)

(*) Voir page brides.

(3) z = Immersion minima per motore senza mantello in funzione continuo S1 compatibilmente con l'NPSHR

y = Immersione minima con motore senza mantello in funzione intermittente S3 compatibilmente con l'NPSHR

(*) Vedere pagina flange.

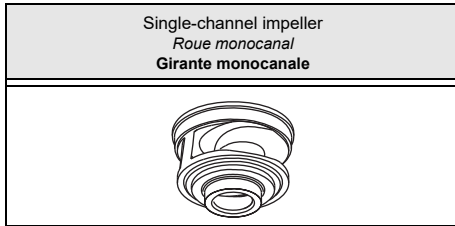

Type Type Tipo	KCM200P...+...62N3	KCM200P...+...62X3
Thermal probes <i>Sondes thermiques</i> Sonda termiche	Yes <i>Oui</i> SI	Yes <i>Oui</i> SI
Conductivity probe <i>Sonde de conductivité</i> Sonda di conduttività	Yes <i>Oui</i> SI	Yes <i>Oui</i> SI

Version cable (1)
Version câble (1)
Cavo Versione (1)

Electric pump type <i>Electropompe type</i> Elettropompa tipo	Power supply <i>Alimentation</i> Alimentazione	Auxiliary <i>Auxiliaire</i> Ausiliario
KCM200PG+011062N3	2x(4x6)x10	1x(4x1,5)x10
KCM200PD+015062N3	2x(4x6)x10	1x(4x1,5)x10
KCM200PA+019562N3	2x(4x10)x10	1x(4x1,5)x10

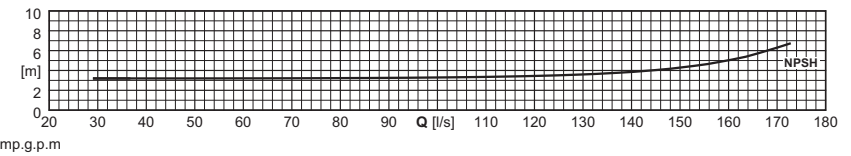
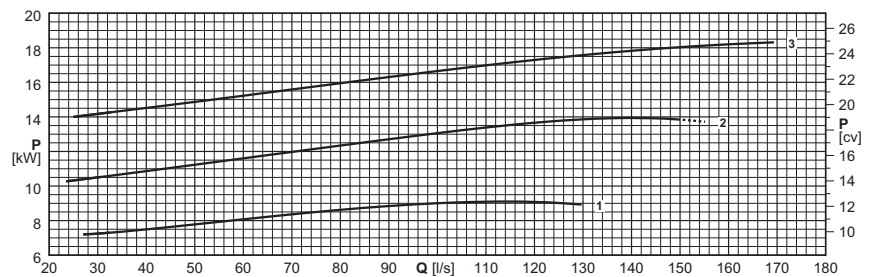
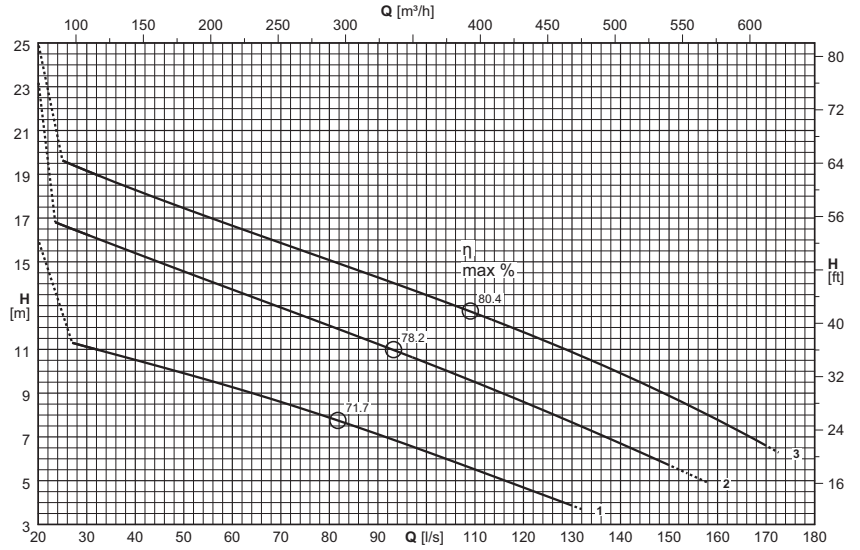

Imp.g.p.m

US.g.p.m

(1) = n°. of cables x (n°. of wires each cable x size [mm²]) x cable length [m] - Cable NSSHÖU-J

Cable length exceeding 10 m on request

(1) = n°. câbles x (n°. conducteurs câble x section [mm²]) x longueur câble [m] - Câble NSSHÖU-J

Sur demande longueur de câble supérieure à 10 m

(1) = n°. cavi x (n°. conduttori per cavo x sezione [mm²]) x lunghezza cavo [m] - Cavo NSSHÖU-J

Lunghezza cavo superiore a 10 m - su richiesta

Electric pump type <i>Electropompe type</i> Elettropompa tipo	Curve <i>Courbe</i> Curva	Motor power <i>Puiss. moteur</i> Potenza motore	Capacity <i>Debit</i> Portata																	
			[l/s]	0	25	30	35	40	45	50	60	70	80	90	100	125	150	172		
			P ₂	[m³/h]	0	90	108	126	144	162	180	216	252	288	324	360	450	540	619,2	
			(N°)	[kW]	Head <i>Hauteur</i> Prevalenza															
			[m]	[m]	13	11,1	10,8	10,5	10,2	9,9	9,3	8,6	7,9	7,1	6,3	4,3				
KCM200PG+011062N3	1	11	[m]	[m]	20,3	16,7	16,2	15,8	15,4	15	14,6	13,7	12,9	12,1	11,2	10,4	8,1	5,7		
KCM200PD+015062N3	2	15	[m]	[m]	23,2	19,6	19,2	18,7	18,3	17,9	17,5	16,7	15,9	15,1	14,3	13,5	11,3	8,9	6,4	
KCM200PA+019562N3	3	19,5	[m]	[m]			3,2	3,2	3,2	3,2	3,2	3,2	3,2	3,2	3,3	3,3	3,5	4,3	6,7	
NPSH _R			[m]	[m]			3,2	3,2	3,2	3,2	3,2	3,2	3,2	3,2	3,3	3,3	3,5	4,3	6,7	

P₂ = Power rated by the motor

Performance tolerance as per: UNI/ISO 9906 Grade 3B

For motor performances specification see page "motor features"

For the accessories specification see page "Accessories"

P₂ = Puissance restituée par le moteur

Tolérances sur les performances selon normes: UNI/ISO 9906 Niveau 3B

Pour caractéristiques techniques moteurs voir page "Caractéristiques des moteurs"

Pour les accessoires voir page "Accessories"

P₂ = Potenza resa dal motore

Tolleranze sulle prestazioni secondo norme: UNI/ISO 9906 Grado 3B

Per caratteristiche motori vedere pagina "caratteristiche motori"

Per accessori vedere pagina accessori

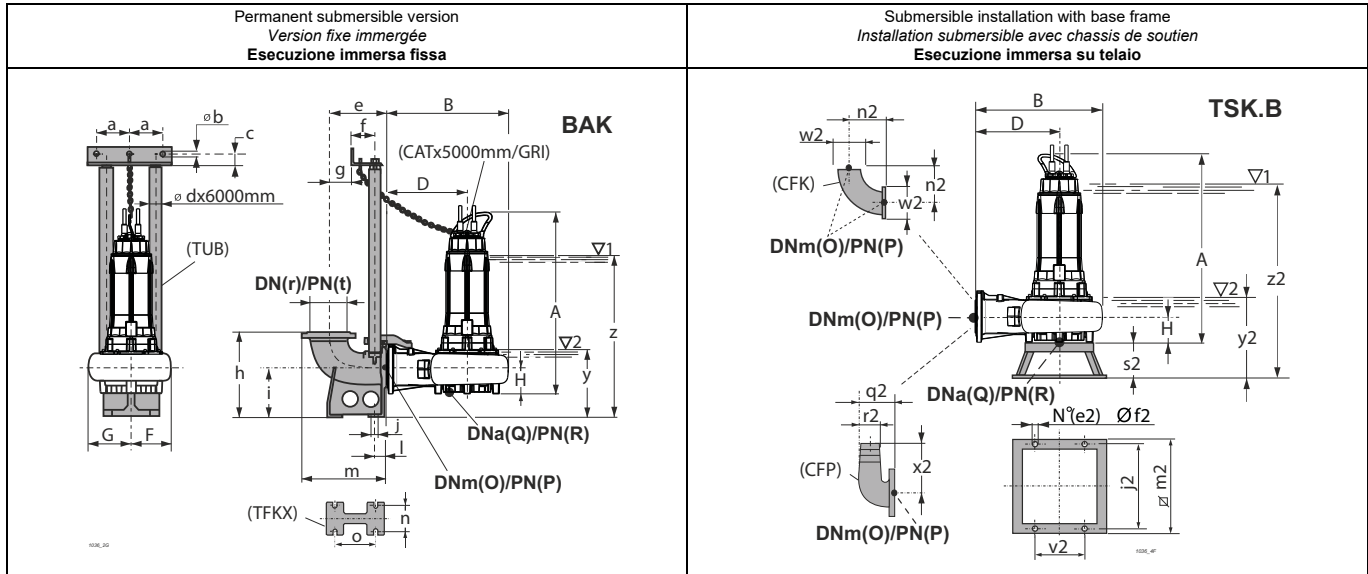

For fixed installation in a dry chamber - vertical (R)
Pour installation fixe en fosse sèche - verticale (R)
Esecuzione per camera asciutta - verticale (R)

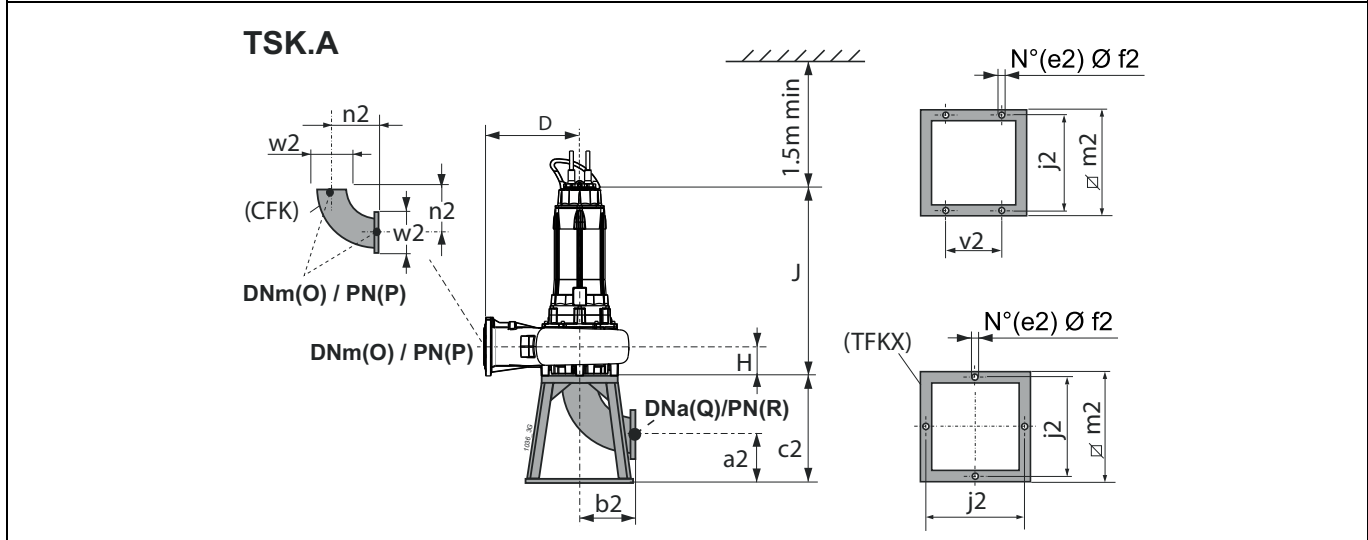

Type Type Tipo	Free passage Passage libre Passaggio Libero	Weight Poids Peso	A	B	D	F	G	H	J	O	P	Q	R	Accessories Accessoires Accessori				
			[mm]	[kg]	[mm]											BAK.	TSK.A	TSK.B
KCM200PG+011062N3	Ø 135	423,28	1280	765	455	277	345	185	1125,5	200	10	200	10	N/M 3"	M	M		
KCM200PD+015062N3	Ø 135	450,23	1280	765	455	277	345	185	1125,5	200	10	200	10	N/M 3"	M	M		
KCM200PA+019562N3	Ø 135	497,48	1280	765	455	277	345	185	1125,5	200	10	200	10	N/M 3"	M	M		
BAK.	a	b	c	d	e	f	g	h	i	j	l	m	n	o	r	t	y	z
BAKN/M 3"	157,5	12,5	35	3"	425	117	220	595	345	24	80	623	250	380	250	10	534	1155
TSK.A	a2	b2	c2	e2	f2	j2	m2	n2	v2	w2								
TSKMA	290	310	600	4	22	600	650	310	-	340								
TSK.B	e2	f2	j2	m2	n2	q2	r2	s2	v2	w2	x2	y2	z2					
TSKMB	4	14	600	650	310	420	200	220	350	340	480	594	1215					

(3) z = Minimum submergence depth for motor without casing with continuous duty S1 (NPSHR permitting)

y = Minimum submergence depth for motor without casing with intermittent duty S3 (NPSHR permitting)

(3) z = Immersion minimum pour moteur sans chemise en service continu S1 (compatible avec le NPSHR)

y = Immersion minimum pour moteur sans chemise en service intermittent S3 (compatible avec le NPSHR)

(3) z = Immersion minima per motore senza mantello in funzione continuo S1 compatibilmente con l'NPSHR

y = Immersion minima con motore senza mantello in funzione intermittente S3 compatibilmente con l'NPSHR

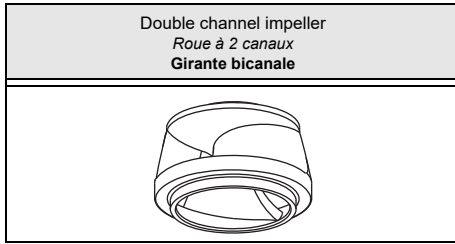

Type Type Tipo	KCD200N...62N3	KCD200N...62X3
Thermal probes Sondes thermiques Sonde termiche	Yes Oui Sì	Yes Oui Sì
Conductivity probe Sonde de conductivité Sonda di conduttività	Yes Oui Sì	Yes Oui Sì

Version cable (1)
Version câble (1)
Cavo Versione (1)

Electric pump type Electropompe type Elettropompa tipo	Power supply Alimentation Alimentazione	Auxiliary Auxiliaire Ausiliario
KCD200NL+011062N3	2x(4x6)x10	1x(4x1,5)x10
KCD200NG+011062N3	2x(4x6)x10	1x(4x1,5)x10
KCD200NA+011062N3	2x(4x6)x10	1x(4x1,5)x10

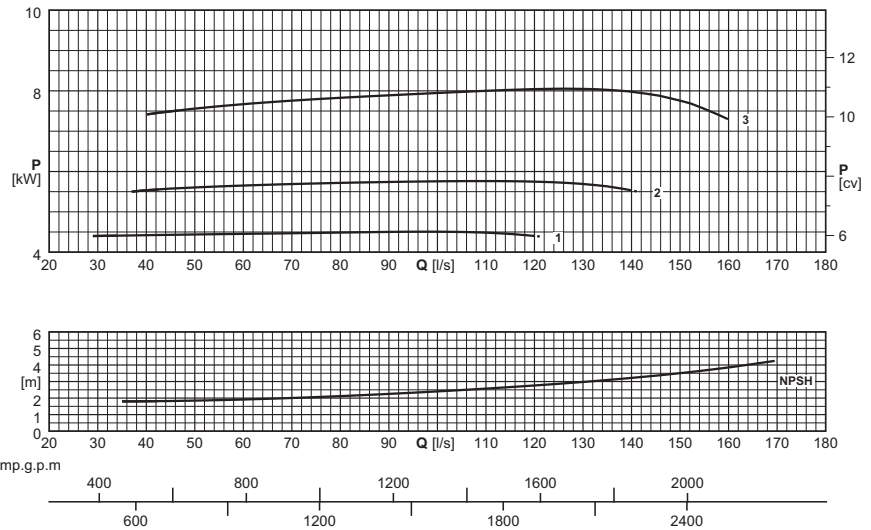
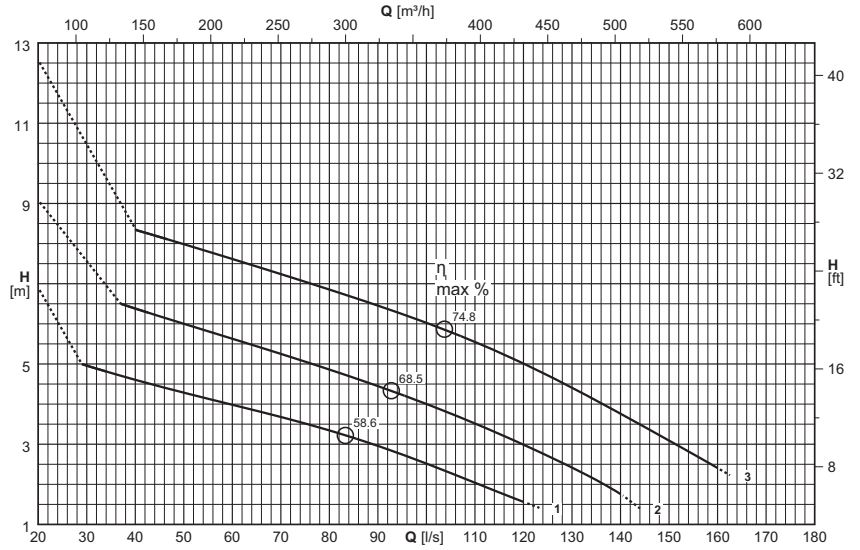

(1) = n°. of cables x (n°. of wires each cable x size [mm²]) x cable length [m] - Cable NSSHÖU-J

Cable length exceeding 10 m on request

(1) = n°. câbles x (n°. conducteurs câble x section [mm²]) x longueur câble [m] - Câble NSSHÖU-J

Sur demande longueur de câble supérieure à 10 m

(1) = n°. cavi x (n°. conduttori per cavo x sezione [mm²]) x lunghezza cavo [m] - Cavo NSSHÖU-J

Lunghezza cavo superiore a 10 m - su richiesta

Electric pump type Electropompe type Elettropompa tipo	Curve Courbe Curva	Motor power Puiss. moteur Potenza motore	Capacity Débit Portata																	
			[l/s]	0	30	35	40	45	50	60	70	80	90	100	125	150	162			
			P ₂	[m³/h]	0	108	126	144	162	180	216	252	288	324	360	450	540	583,2		
			(N°)	[kW]	Head Hauteur Prevalenza															
			[m]	5,9	5	4,8	4,6	4,4	4,3	4	3,7	3,3	3	2,5						
KCD200NL+011062N3	1	11	[m]	5,9	5	4,8	4,6	4,4	4,3	4	3,7	3,3	3	2,5						
KCD200NG+011062N3	2	11	[m]	8,1			6,4	6,2	6	5,6	5,3	4,9	4,4	4	2,7					
KCD200NA+011062N3	3	11	[m]	11,6				8,2	8	7,6	7,2	6,9	6,5	6	4,7	3,1	2,3			
NPSH _R			[m]			1,8	1,8	1,8	1,8	1,9	2	2,1	2,3	2,4	2,9	3,5	3,9			

P₂ = Power rated by the motor

Performance tolerance as per: UNI/ISO 9906 Grade 3B

For motor performances specification see page "motor features"

For the accessories specification see page "Accessories"

The impellers will be trimmed to meet the duty point

P₂ = Puissance restituée par le moteur

Tolérances sur les performances selon normes: UNI/ISO 9906 Niveau 3B

Pour caractéristiques techniques moteurs voir page "Caractéristiques des moteurs"

Pour les accessoires voir page "Accessories"

Le point de fonctionnement désiré peut être obtenu par rognage de roue

P₂ = Potenza resa dal motore

Tolleranze sulle prestazioni secondo norme: UNI/ISO 9906 Grado 3B

Per caratteristiche motori vedere pagina "caratteristiche motori"

Per accessori vedere pagina accessori

Le giranti vengono tornite in modo da ottenere il punto di lavoro richiesto

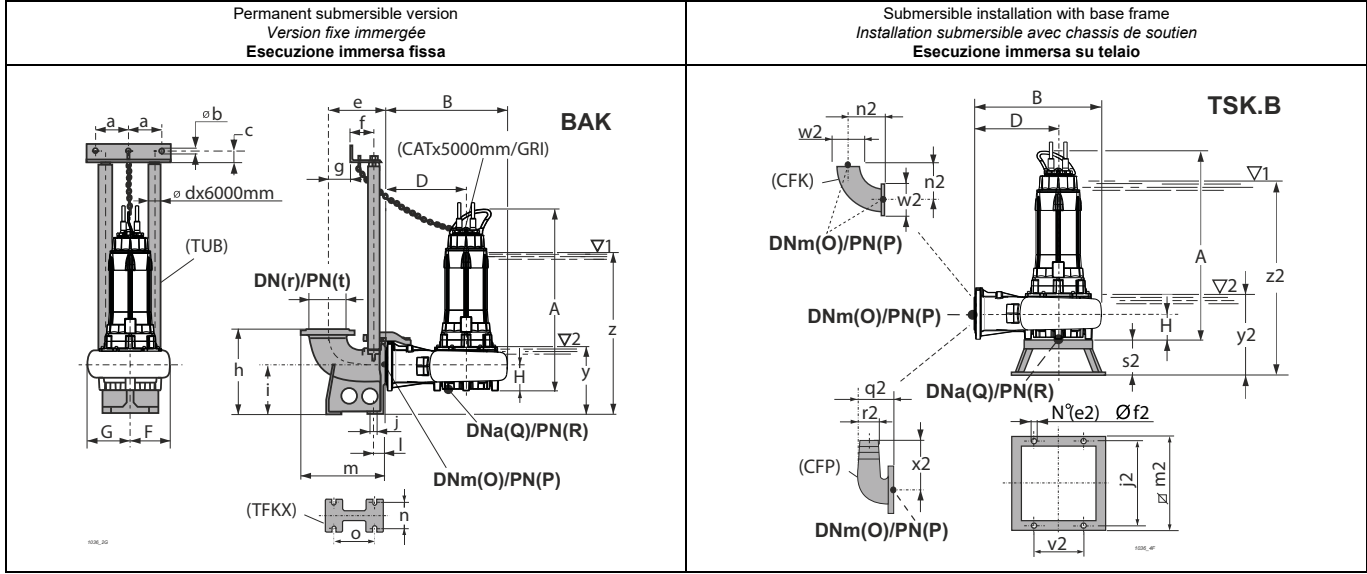

For fixed installation in a dry chamber - vertical (R)
Pour installation fixe en fosse sèche - verticale (R)
Esecuzione per camera asciutta - verticale (R)

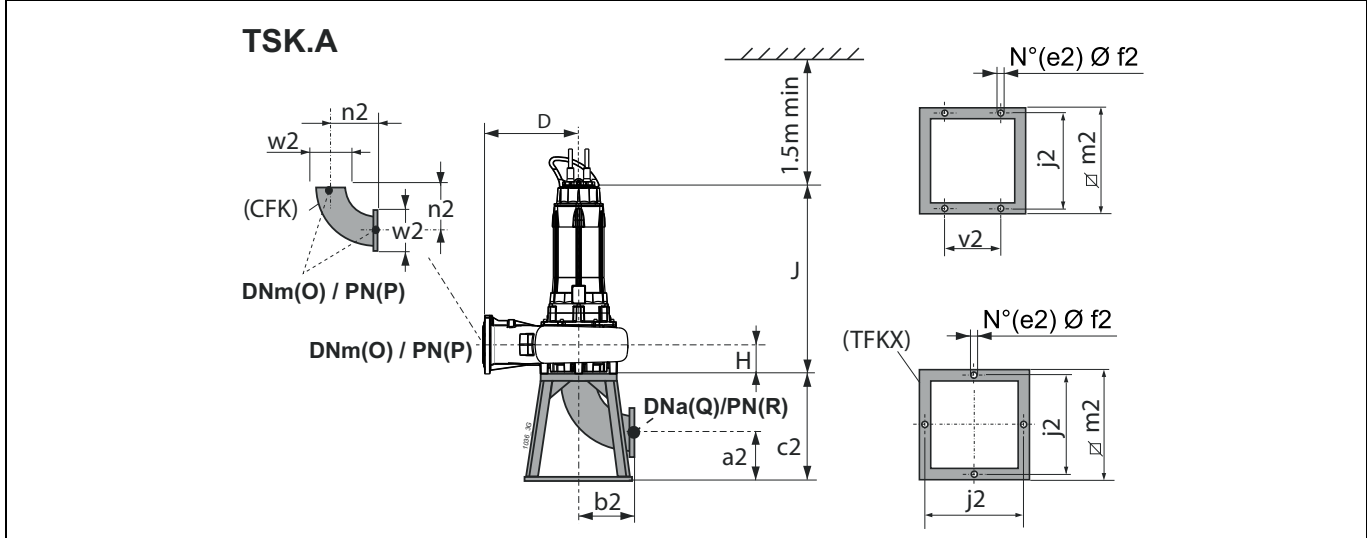

Type Type Tipo	Free passage Passage libre Passaggio Libero	Weight Poids Peso	A	B	D	F	G	H	J	O	P	Q	R	Accessories Accessoires Accessori				
			[mm]	[kg]	[mm]											BAK.	TSK.A	TSK.B
KCD200NL+011062N3	Ø 100x110	387,33	1259	835	550	236	334	170	1104,5	200	10	200	10	N/M 3"	M	M		
KCD200NG+011062N3	Ø 100x110	388,03	1259	835	550	236	334	170	1104,5	200	10	200	10	N/M 3"	M	M		
KCD200NA+011062N3	Ø 100x110	389,73	1259	835	550	236	334	170	1104,5	200	10	200	10	N/M 3"	M	M		
BAK.	a	b	c	d	e	f	g	h	i	j	l	m	n	o	r	t	y	z
BAKN/M 3"	157,5	12,5	35	3"	425	117	220	595	345	24	80	623	250	380	250	10	528	1149
TSK.A	a2	b2	c2	e2	f2	j2	m2	n2	v2	w2								
TSKMA	290	310	600	4	22	600	650	310	-	340								
TSK.B	e2	f2	j2	m2	n2	q2	r2	s2	v2	w2	x2	y2	z2					
TSKMB	4	14	600	650	310	420	200	220	350	340	480	573	1194					

(3) z = Minimum submergence depth for motor without casing with continuous duty S1 (NPSHR permitting)

y = Minimum submergence depth for motor without casing with intermittent duty S3 (NPSHR permitting)

(3) z = Immersion minimum pour moteur sans chemise en service continu S1 (compatible avec le NPSHR)

y = Immersion minimum pour moteur sans chemise en service intermittent S3 (compatible avec le NPSHR)

(3) z = Immersion minima per motore senza mantello in funzione continuo S1 compatibilmente con l'NPSHR

y = Immersion minima con motore senza mantello in funzione intermittente S3 compatibilmente con l'NPSHR

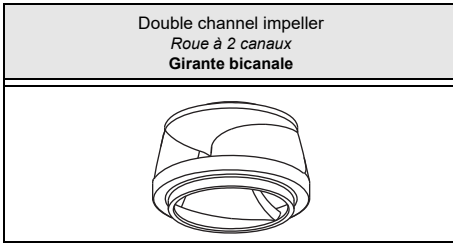

Type Type Tipo	KCD200N...42N3	KCD200N...42X3
Thermal probes Sondes thermiques Sonde termiche	Yes Oui Sì	Yes Oui Sì
Conductivity probe Sonde de conductivité Sonda di conduttività	Yes Oui Sì	Yes Oui Sì

Version cable (1)
Version câble (1)
Cavo Versione (1)

Electric pump type Electropompe type Elettropompa tipo	Power supply Alimentation Alimentazione	Auxiliary Auxiliaire Ausiliario
KCD200NL+016542N3	2x(4x6)x10	1x(4x1,5)x10
KCD200NG+019342N3	2x(4x10)x10	1x(4x1,5)x10
KCD200ND+021042N3	2x(4x10)x10	1x(4x1,5)x10
KCD200NA+026042N3	2x(4x10)x10	1x(4x1,5)x10

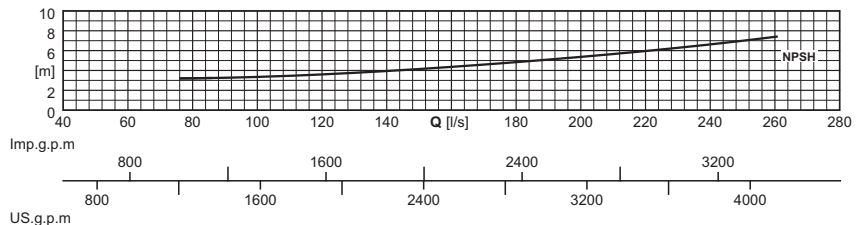
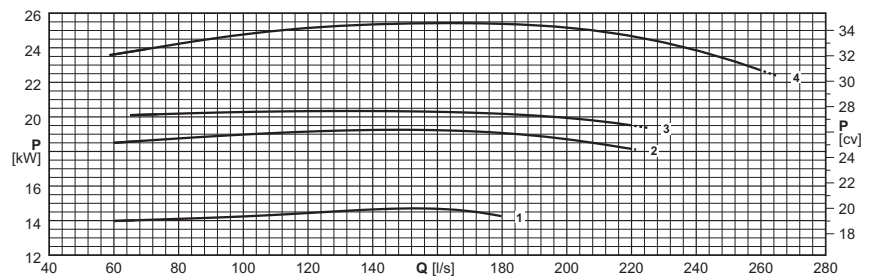
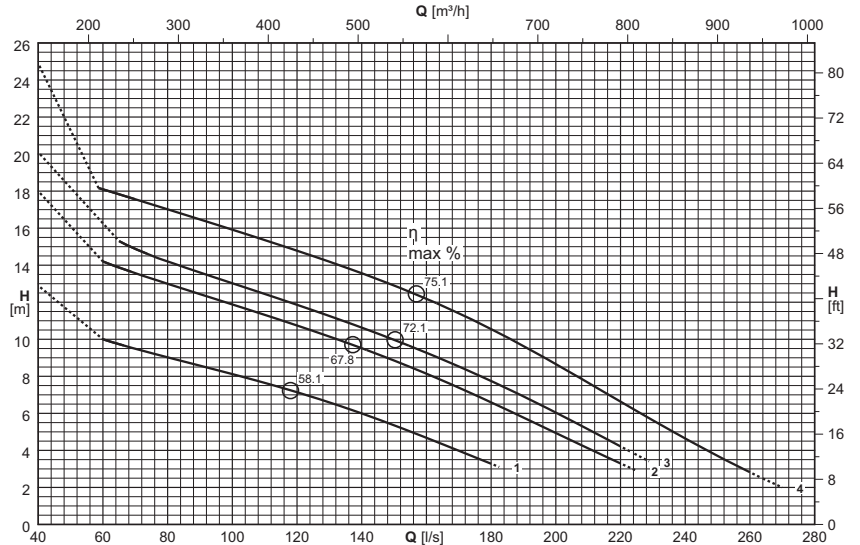

(1) = n°. of cables x (n°. of wires each cable x size [mm²]) x cable length [m] - Câble NSSHOU-J

Cable length exceeding 10 m on request

(1) = n°. câbles x (n°. conducteurs câble x section [mm²]) x longueur câble [m] - Câble NSSHOU-J

Sur demande longueur de câble supérieure à 10 m

(1) = n°. cavi x (n°. conduttori per cavo x sezione [mm²]) x lunghezza cavo [m] - Cavo NSSHOU-J

Lunghezza cavo superiore a 10 m - su richiesta

Electric pump type Electropompe type Elettropompa tipo	Curve Courbe Curva	Motor power Puiss. moteur Potenza motore P ₂	Capacity Débit Portata															
			[l/s]	0	60	70	80	90	100	125	150	175	200	225	250	270		
	(N°)	[kW]	[m ³ /h]	0	216	252	288	324	360	450	540	630	720	810	900	972		
			Head Hauteur Prevalenza															
			[m]	12,9	10	9,5	9	8,6	8,1	6,9	5,4	3,6						
KCD200NL+016542N3	1	16,5	[m]	12,9	10	9,5	9	8,6	8,1	6,9	5,4	3,6						
KCD200NG+019342N3	2	19,3	[m]	18	14,2	13,6	13	12,4	11,9	10,4	8,8	7	4,9	2,9				
KCD200ND+021042N3	3	21	[m]	20,1		14,9	14,2	13,6	13	11,6	10	8,1	6	3,8				
KCD200NA+026042N3	4	26	[m]	24,9	18,1	17,6	17	16,5	15,9	14,5	12,9	11	8,7	6,1	3,7	2		
NPSH _R			[m]				3,2	3,3	3,4	3,7	4,1	4,7	5,4	6,1	7			

P₂ = Power rated by the motor

Performance tolerance as per: UNI/ISO 9906 Grade 3B

For motor performances specification see page "motor features"

For the accessories specification see page "Accessories"

The impellers will be trimmed to meet the duty point

P₂ = Puissance restituée par le moteur

Tolérances sur les performances selon normes: UNI/ISO 9906 Niveau 3B

Pour caractéristiques techniques moteurs voir page "Caractéristiques des moteurs"

Pour les accessoires voir page "Accessories"

Le point de fonctionnement désiré peut être obtenu par rognage de roue

P₂ = Potenza resa dal motore

Tolleranze sulle prestazioni secondo norme: UNI/ISO 9906 Grado 3B

Per caratteristiche motori vedere pagina "caratteristiche motori"

Per accessori vedere pagina accessori

Le giranti vengono tornite in modo da ottenere il punto di lavoro richiesto

(4)P

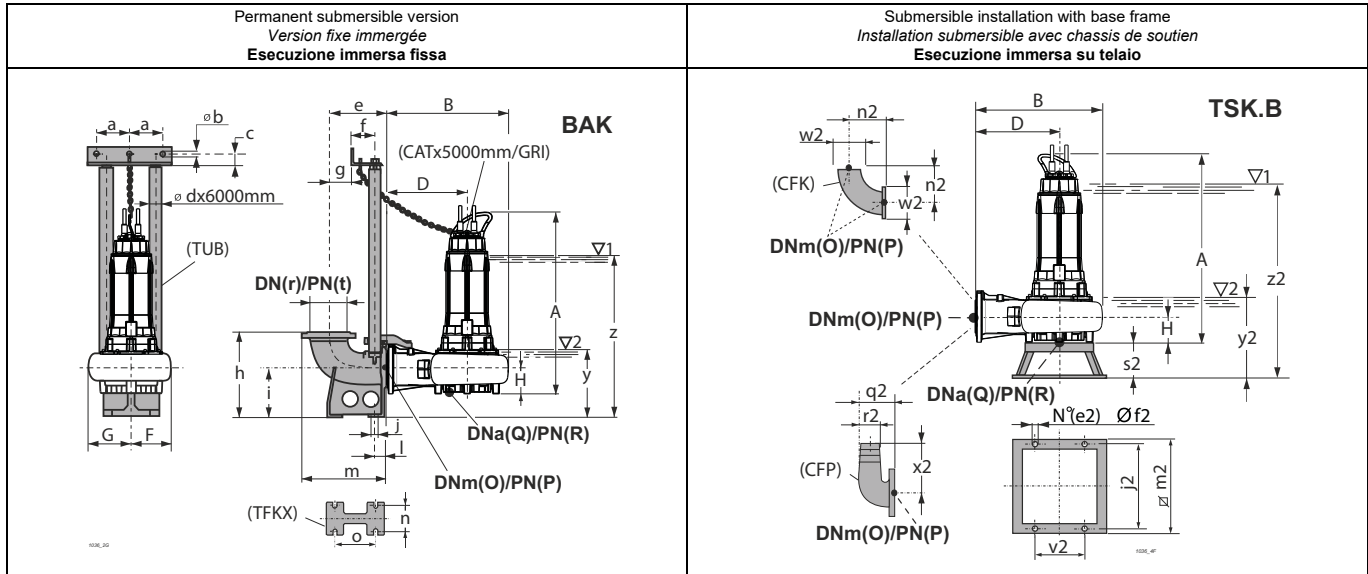

For fixed installation in a dry chamber - vertical (R)
Pour installation fixe en fosse sèche - verticale (R)
Esecuzione per camera asciutta - verticale (R)

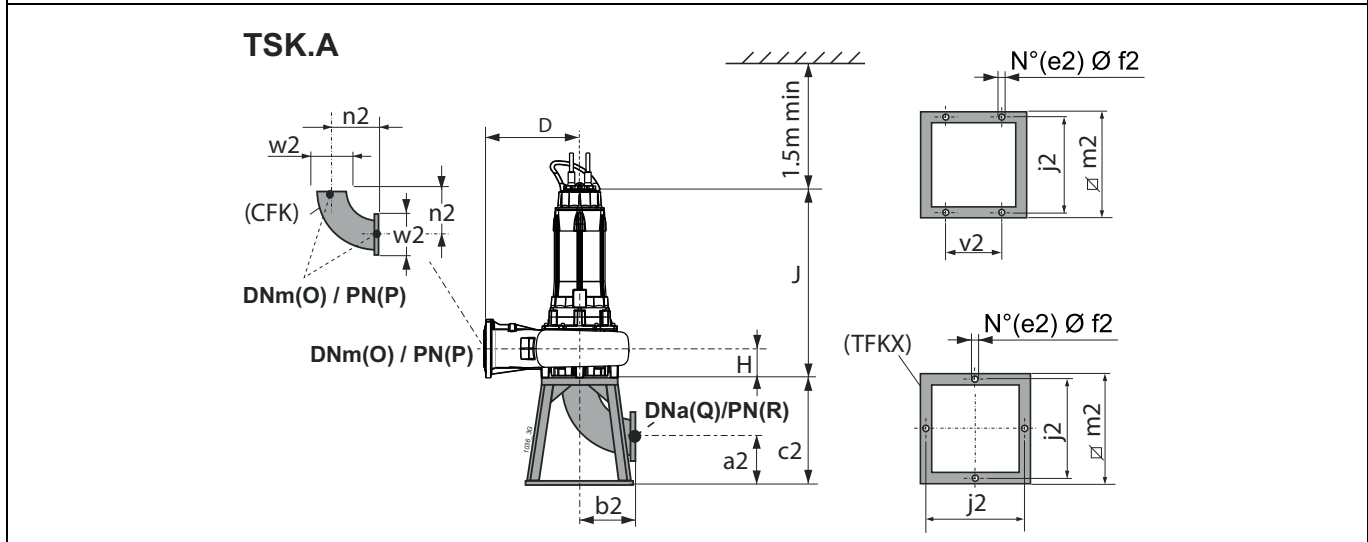

Type Type Tipo	Free passage Passage libre Passaggio Libero	Weight Poids Peso	A	B	D	F	G	H	J	O	P	Q	R	Accessories Accessoires Accessori						
			[mm]	[kg]	[mm]											BAK	TSK.A	TSK.B		
KCD200NL+016542N3	Ø 100x110	374,05	1259	835	550	236	334	170	1104,5	200	10	200	10	N/M 3"	M	M				
KCD200NG+019342N3	Ø 100x110	396,63	1259	835	550	236	334	170	1104,5	200	10	200	10	N/M 3"	M	M				
KCD200ND+021042N3	Ø 100x110	421,23	1259	835	550	236	334	170	1104,5	200	10	200	10	N/M 3"	M	M				
KCD200NA+026042N3	Ø 100x110	422,13	1259	835	550	236	334	170	1104,5	200	10	200	10	N/M 3"	M	M				
BAK.			a	b	c	d	e	f	g	h	i	j	l	m	n	o	r	t	y	z
BAKN/M 3"			157,5	12,5	35	3"	425	117	220	595	345	24	80	623	250	380	250	10	528	1149
TSK.A			a2	b2	c2	e2	f2	j2	m2	n2	v2	w2								
TSKMA			290	310	600	4	22	600	650	310	-	340								
TSK.B			e2	f2	j2	m2	n2	q2	r2	s2	v2	w2	x2	y2	z2					
TSKMB			4	14	600	650	310	420	200	220	350	340	480	573	1194					

(3) z = Minimum submergence depth for motor without casing with continuous duty S1 (NPSHR permitting)
y = Minimum submergence depth for motor without casing with intermittent duty S3 (NPSHR permitting)

(3) z = Immersion minimum pour moteur sans chemise en service continu S1 (compatible avec le NPSHR)
y = Immersion minimum pour moteur sans chemise en service intermittent S3 (compatible avec le NPSHR)

(3) z = Immersion minima per motore senza mantello in funzione continuo S1 compatibilmente con l'NPSHR
y = Immersione minima con motore senza mantello in funzione intermittente S3 compatibilmente con l'NPSHR

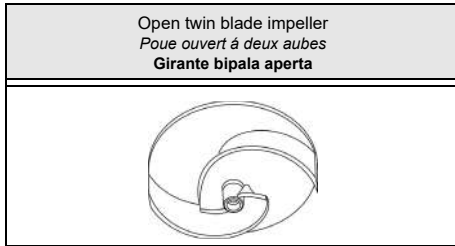

Type Type Tipo	KCA200N...42N3	KCA200N...42X3
Thermal probes Sondes thermiques Sonde termiche	Yes Oui Sì	Yes Oui Sì
Conductivity probe Sonde de conductivité Sonda di conduttività	Yes Oui Sì	Yes Oui Sì

Version cable (1) Version câble (1) Cavo Versione (1)		
Electric pump type Electropompe type Elettropompa tipo	Power supply Alimentation Alimentazione	Auxiliary Auxiliaire Ausiliario
KCA200NL+016542N3	2x(4x6)x10	1x(4x1,5)x10
KCA200NG+019342N3	2x(4x10)x10	1x(4x1,5)x10
KCA200ND+021042N3	2x(4x10)x10	1x(4x1,5)x10
KCA200NA+026042N3	2x(4x10)x10	1x(4x1,5)x10

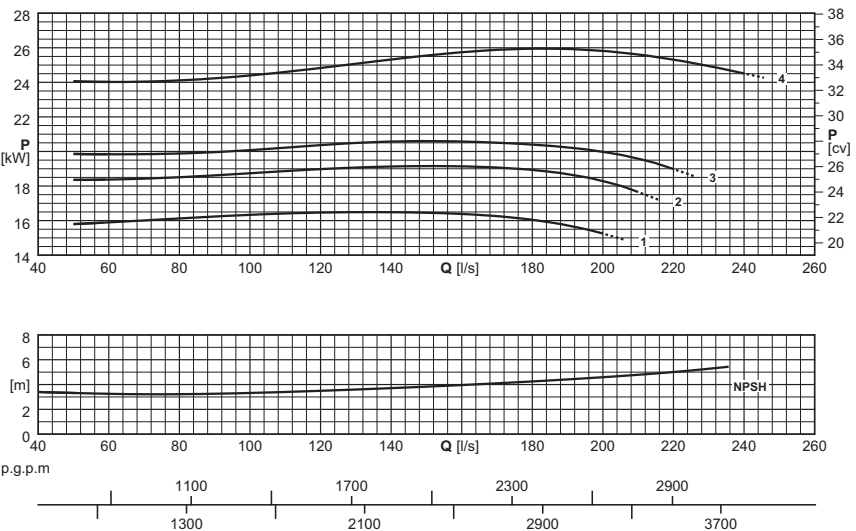
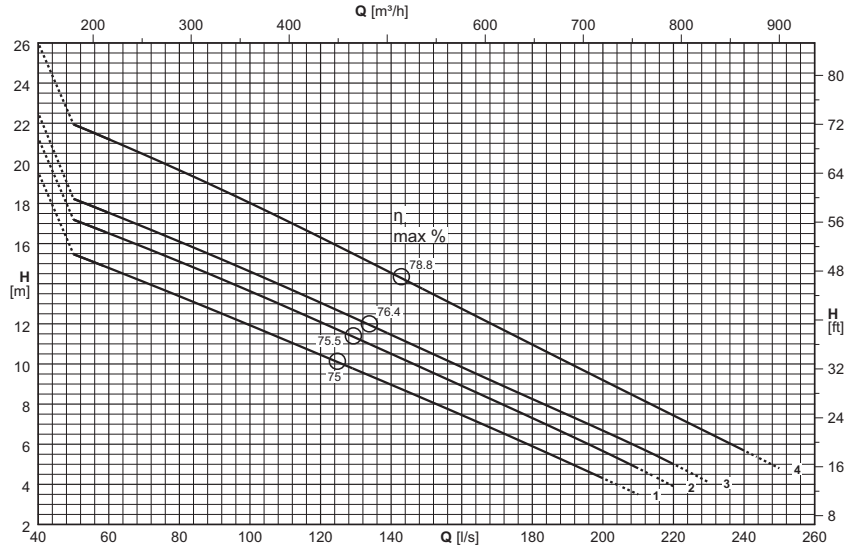

(1) = n°. of cables x (n°. of wires each cable x size [mm²]) x cable length [m] - Cable NSSHOU-J
Cable length exceeding 10 m on request

(1) = n°. câbles x (n°. conducteurs câble x section [mm²]) x longueur câble [m] - Câble NSSHOU-J
Sur demande longueur de câble supérieure à 10 m

(1) = n°. cavi x (n°. conduttori per cavo x sezione [mm²]) x lunghezza cavo [m] - Cavo NSSHOU-J
Lunghezza cavo superiore a 10 m - su richiesta

Electric pump type Electropompe type Elettropompa tipo	Curve Courbe Curva	Motor power Puiss. moteur Potenza motore	Capacity Débit Portata														
			[l/s]	0	60	70	80	90	100	125	150	175	200	225	250		
			P ₂	[m ³ /h]	0	216	252	288	324	360	450	540	630	720	810	900	
			(N°)	[kW]	Head Hauteur Prevalenza												
KCA200NL+016542N3	1	16,5	[m]	17,6	14,8	14,1	13,4	12,7	11,9	10,1	8,2	6,3	4,3				
KCA200NG+019342N3	2	19,3	[m]	19,3	16,5	15,8	15,1	14,4	13,6	11,7	9,7	7,7	5,7				
KCA200ND+021042N3	3	21	[m]	20,5	17,5	16,8	16,1	15,4	14,6	12,7	10,6	8,6	6,7	4,6			
KCA200NA+026042N3	4	26	[m]	24,7	21,2	20,4	19,7	18,8	18	15,9	13,6	11,4	9,2	7	4,8		
NPSH _R			[m]		3,3	3,2	3,2	3,3	3,3	3,5	3,8	4,2	4,6	5,1			

P₂ = Power rated by the motor
Performance tolerance as per:
UNI/ISO 9906 Grade 3B

For motor performances specification see page "motor features"

For the accessories specification see page "Accessories"
The impellers will be trimmed to meet the duty point

P₂ = Puissance restituée par le moteur
Tolérances sur les performances selon normes:
UNI/ISO 9906 Niveau 3B
Pour caractéristiques techniques moteurs voir page "Caractéristiques des moteurs"

For the accessories voir page "Accessories"
Le point de fonctionnement désiré peut être obtenu par rognage de roue

P₂ = Potenza resa dal motore
Tolleranze sulle prestazioni secondo norme:
UNI/ISO 9906 Grado 3B

Per caratteristiche motori vedere pagina "caratteristiche motori"

Per accessori vedere pagina accessori
Le giranti vengono tornite in modo da ottenere il punto di lavoro richiesto

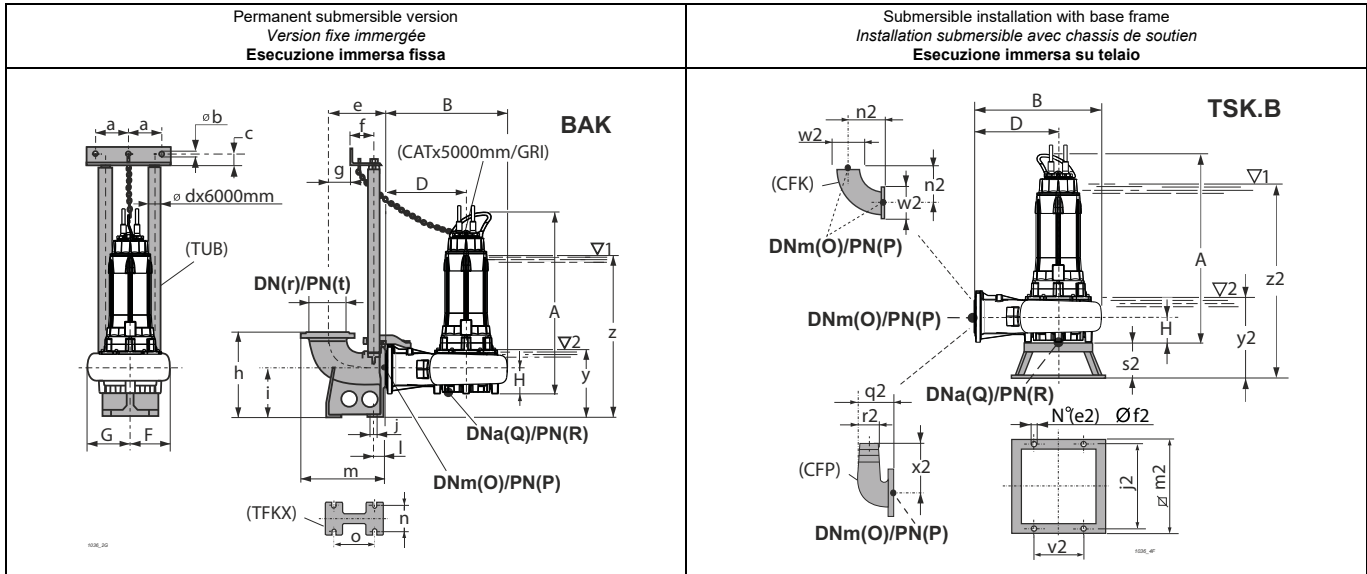

For fixed installation in a dry chamber - vertical (R)
Pour installation fixe en fosse sèche - verticale (R)
Esecuzione per camera asciutta - verticale (R)

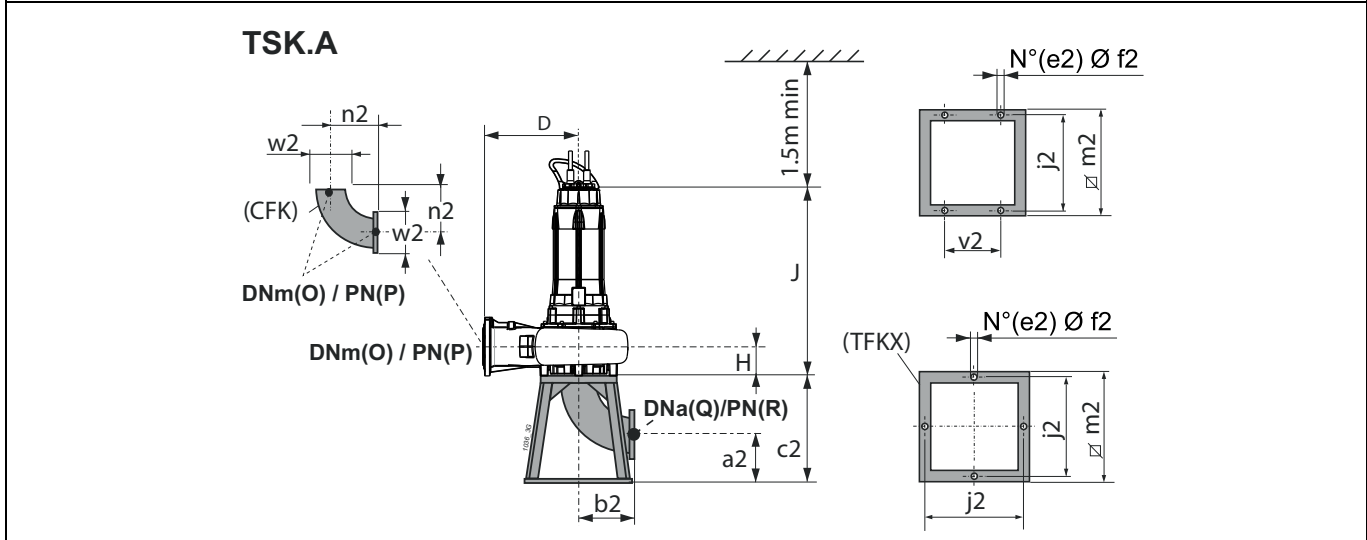

Type Type Tipo	Free passage Passage libre Passaggio Libero	Weight Poids Peso	A	B	D	F	G	H	J	O	P	Q	R	Accessories Accessoires Accessori		
			[mm]	[kg]	[mm]											BAK
KCA200NL+016542N3	---	364,88	1270	865	575	245	333	179	1115,5	200	10	200	10	N/M 3"	M	M
KCA200NG+019342N3	---	383,47	1270	865	575	245	333	179	1115,5	200	10	200	10	N/M 3"	M	M
KCA200ND+021042N3	---	411,12	1270	865	575	245	333	179	1115,5	200	10	200	10	N/M 3"	M	M
KCA200NA+026042N3	---	412,5	1270	865	575	245	333	179	1115,5	200	10	200	10	N/M 3"	M	M

BAK.			a	b	c	d	e	f	g	h	i	j	l	m	n	o	r	t	y	z
BAKN/M 3"			157,5	12,5	35	3"	425	117	220	595	345	24	80	623	250	380	250	10	528	1281,5
TSK.A			a2	b2	c2	e2	f2	j2	m2	n2	v2	w2								
TSKMA			290	310	600	4	22	600	650	310	-	340								
TSK.B			e2	f2	j2	m2	n2	q2	r2	s2	v2	w2	x2	y2	z2					
TSKM B			4	14	600	650	310	420	200	220	350	340	480	582	1335,5					

(3) z = Minimum submergence depth for motor without casing with continuous duty S1 (NPSHR permitting)

(3) z = Immersion minimum pour moteur sans chemise en service continu S1 (compatible avec le NPSHR)

(3) z = Immersion minima per motore senza mantello in funzione continuo S1 compatibilmente con l'NPSHR

y = Minimum submergence depth for motor without casing with intermittent duty S3 (NPSHR permitting)

y = Immersion minimum pour moteur sans chemise en service intermittent S3 (compatible avec le NPSHR)

y = Immersion minima con motore senza mantello in funzione intermittente S3 compatibilmente con l'NPSHR

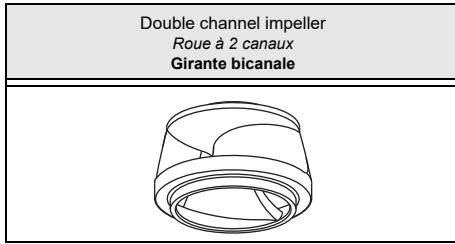

Type Type Tipo	KCD250P...+...62N3	KCD250P...+...62X3
Thermal probes Sondes thermiques Sonde termiche	Yes Oui Sì	Yes Oui Sì
Conductivity probe Sonde de conductivité Sonda di conduttività	Yes Oui Sì	Yes Oui Sì

Version cable (1)
Version câble (1)
Cavo Versione (1)

Electric pump type Electropompe type Elettropompa tipo	Power supply Alimentation Alimentazione	Auxiliary Auxiliaire Ausiliario
KCD250PI+011062N3	2x(4x6)x10	1x(4x1,5)x10
KCD250PD+015062N3	2x(4x6)x10	1x(4x1,5)x10
KCD250PA+019562N3	2x(4x10)x10	1x(4x1,5)x10

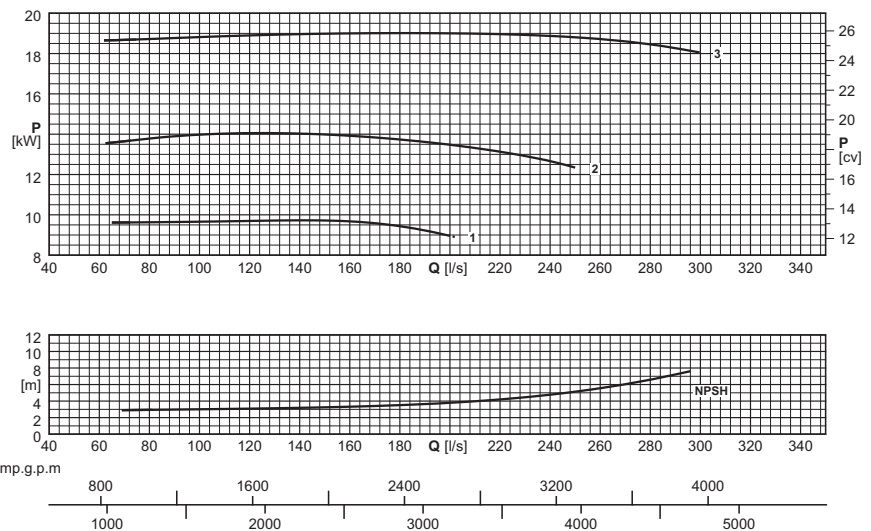
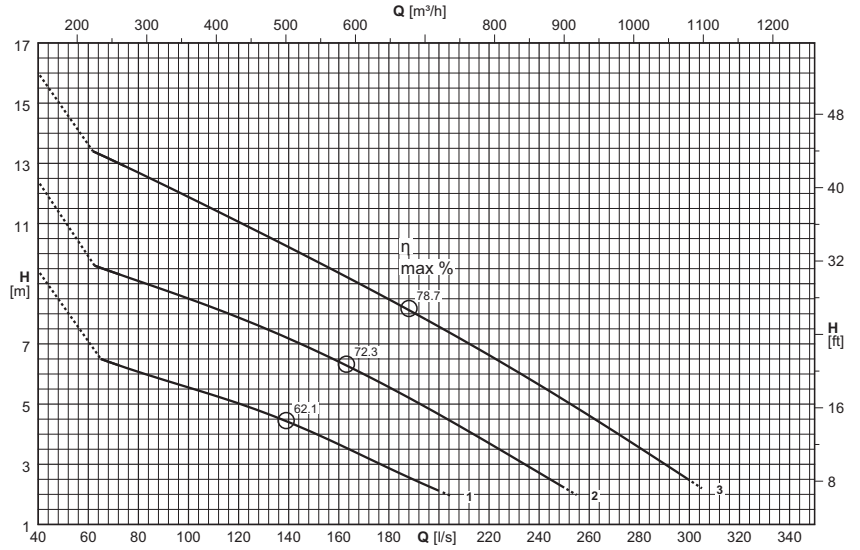

(1) = n°. of cables x (n°. of wires each cable x size [mm²]) x cable length [m] - Cable NSSHÖU-J

Cable length exceeding 10 m on request

(1) = n°. câbles x (n°. conducteurs câble x section [mm²]) x longueur câble [m] - Câble NSSHÖU-J

Sur demande longueur de câble supérieure à 10 m

(1) = n°. cavi x (n°. conduttori per cavo x sezione [mm²]) x lunghezza cavo [m] - Cavo NSSHÖU-J

Lunghezza cavo superiore a 10 m - su richiesta

Electric pump type Electropompe type Elettropompa tipo	Curve Courbe Curva	Motor power Puiss. moteur Potenza motore	Capacity Débit Portata															
			[l/s]	0	70	80	90	100	125	150	175	200	225	250	275	300	305	
	(N°)	[kW]	[m ³ /h]	0	252	288	324	360	450	540	630	720	810	900	990	1080	1098	
			Head Hauteur Prevalenza															
			[m]	8,4	6,4	6,1	5,8	5,6	4,9	4	3,1	2,1						
KCD250PI+011062N3	1	11	[m]	8,4	6,4	6,1	5,8	5,6	4,9	4	3,1	2,1						
KCD250PD+015062N3	2	15	[m]	11,4	9,4	9,1	8,8	8,5	7,7	6,8	5,8	4,7	3,5	2,2				
KCD250PA+019562N3	3	19,5	[m]	15	13,1	12,7	12,3	11,9	10,8	9,8	8,7	7,6	6,4	5,1	3,8	2,5	2,2	
NPSH _R			[m]		2,9	2,9	3	3	3,1	3,2	3,5	3,8	4,3	5,1	6,3	7,9		

P₂ = Power rated by the motor

Performance tolerance as per: UNI/ISO 9906 Grade 3B

For motor performances specification see page "motor features"

For the accessories specification see page "Accessories"

The impellers will be trimmed to meet the duty point

P₂ = Puissance restituée par le moteur

Tolérances sur les performances selon normes: UNI/ISO 9906 Niveau 3B

Pour caractéristiques techniques moteurs voir page "Caractéristiques des moteurs"

Pour les accessoires voir page "Accessories"

Le point de fonctionnement désiré peut être obtenu par rognage de roue

P₂ = Potenza resa dal motore

Tolleranze sulle prestazioni secondo norme: UNI/ISO 9906 Grado 3B

Per caratteristiche motori vedere pagina "caratteristiche motori"

Per accessori vedere pagina accessori

Le giranti vengono tornite in modo da ottenere il punto di lavoro richiesto

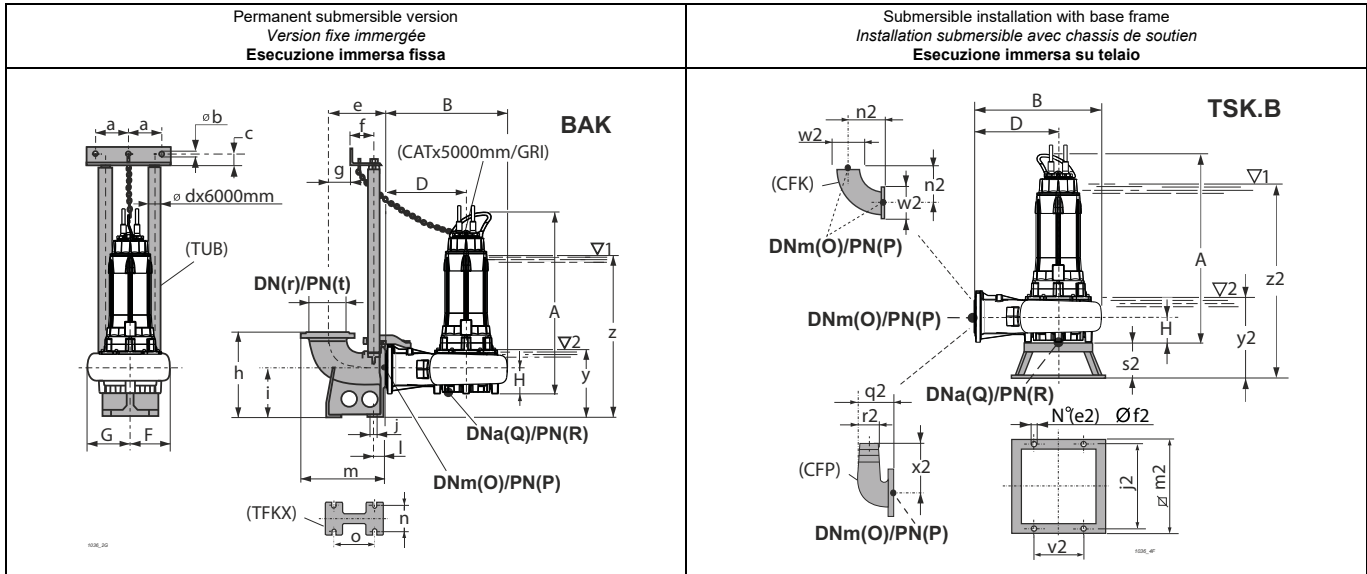

For fixed installation in a dry chamber - vertical (R)
Pour installation fixe en fosse sèche - verticale (R)
Esecuzione per camera asciutta - verticale (R)

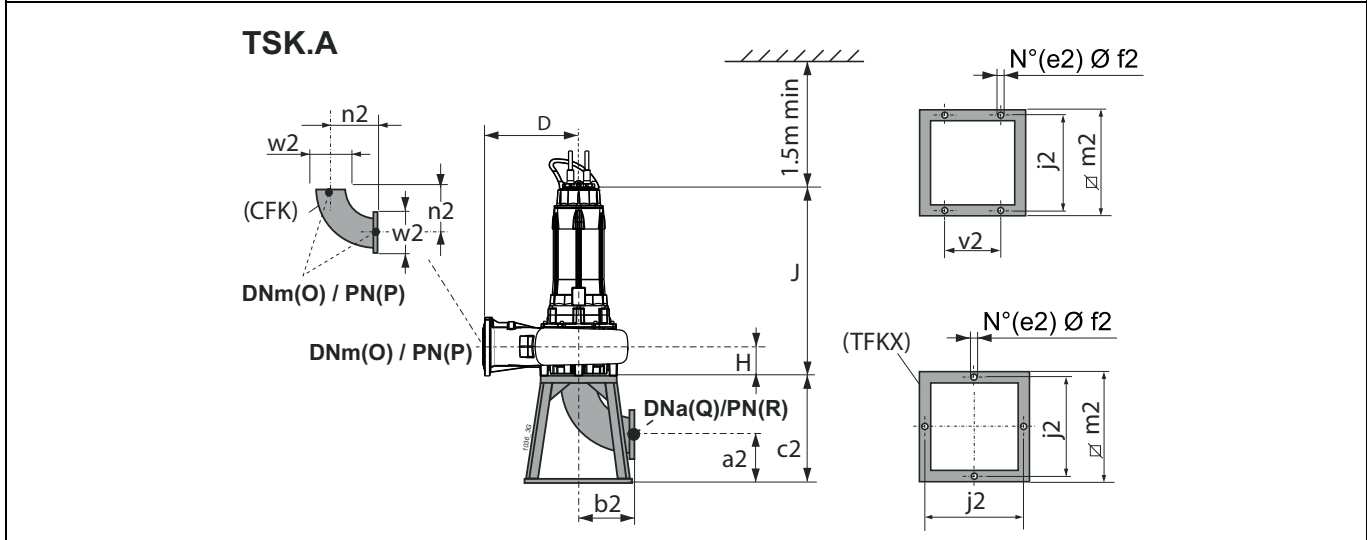

Type Type Tipo	Free passage Passage libre Passaggio Libero	Weight Poids Peso	[mm]												Accessories Accessoires Accessori			
			A	B	D	F	G	H	J	O	P	Q	R	BAK.	TSK.A	TSK.B		
KCD250PI+011062N3	Ø 115x130	412,83	1305	843	500	282	404	200	1150,5	250	10	250	10	300/250 3"	250	250		
KCD250PD+015062N3	Ø 115x130	477,83	1305	843	500	282	404	200	1150,5	250	10	250	10	300/250 3"	250	250		
KCD250PA+019562N3	Ø 115x130	524,33	1305	843	500	282	404	200	1150,5	250	10	250	10	300/250 3"	250	250		
BAK.	a	b	c	d	e	f	g	h	i	j	l	m	n	o	r	t	y	z
BAK300/250 3"	157,5	12,5	35	3"	450	117	245	700	400	24	85	673	310	425	300	10	599	1220
TSK.A	a2	b2	c2	e2	f2	j2	m2	n2	v2	w2								
TSK250A	215	385	600	4	22	600	650	385	-	395								
TSK.B	e2	f2	j2	m2	n2	q2	r2	s2	v2	w2	x2	y2	z2					
TSK250B	4	14	600	650	385	525	250	220	350	395	575	619	1240					

(3) z = Minimum submergence depth for motor without casing with continuous duty S1 (NPSHR permitting)

(3) z = Immersion minimum pour moteur sans chemise en service continu S1 (compatible avec le NPSHR)

(3) z = Immersion minima per motore senza mantello in funzione continuo S1 compatibilmente con l'NPSHR

y = Minimum submergence depth for motor without casing with intermittent duty S3 (NPSHR permitting)

y = Immersion minimum pour moteur sans chemise en service intermittent S3 (compatible avec le NPSHR)

y = Immersion minima con motore senza mantello in funzione intermittente S3 compatibilmente con l'NPSHR

The following are also available: Anchoring bolts, level regulators and Electric panels
Accessoires supplémentaires: Tire-fond, Régulateurs de niveau et coffrets électriques

Sono inoltre disponibili: tirafondi, regolatori di livello e quadri elettrici

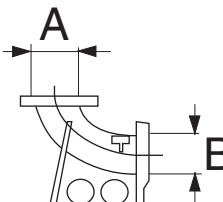
Duck-foot pedestal for automatic coupling (*) <i>Pied d'assise pour accouplement automatique (*)</i> Piede di accoppiamento automatico (*)	Type Type Tipo	A		B		Weight Poids Peso [Kg]	Electric pump type <i>Electropompe type</i> Elettropompa tipo								
		DN	UNI PN	DN	UNI PN		KCW100N	KCM100N	KCA100N	KCM150N	KCA150N	KCM200P	KCD200N	KCA200N	KCD250P
			BAK100 2"	100	16		100	16	21	-	● (4P)	-	-	-	-
	BAK300/250 3"	300	10	250	10	160	-	-	-	-	-	-	-	-	●
	BAKG 2"	100	16	100	16	30	●	● (2P)	●	-	-	-	-	-	-
	BAKM/I 3"	200	10	150	16	88	-	-	-	●	●	-	-	-	-
	BAKN/M 3"	250	10	200	10	132	-	-	-	-	●	●	●	-	-

(*) = Complete with:
Pump coupling bracket (nodular cast iron)
Rail pipes anchor bracket (stainless steel)
Screw and nuts

(*) = Composé de:
Support de guidage (fonte à graphite sphéroïdale)
Support de barre de guidage (acier inox)
Visserie

(*) = Completo di:
Staffa corpo premente (ghisa sferoidale)
Staffa per tubi guida (acciaio inox)
Minuteria

Rail pipes (*) (dipped galvanized steel) <i>Barres de guidage (*) (acier galvanisé à chaud)</i> Tubi guida (*) (acciaio zincato a caldo)	Type Type Tipo	Weight Poids Peso [Kg]	Electric pump type <i>Electropompe type</i> Elettropompa tipo									
			KCW100N	KCM100N	KCA100N	KCM150N	KCA150N	KCM200P	KCD200N	KCA200N	KCD250P	
	TUB 2"	21	●	●	●	-	-	-	-	-	-	-
	TUB 3"	51	-	-	-	●	●	●	●	●	●	●

(*) = On demand: stainless steel

(*) = Sur demande: acier inox

(*) = Su richiesta: acciaio inox

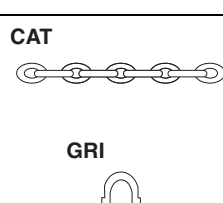
Chain and Shackle Kit (*) <i>Kit Chaîne et manille (*)</i> Kit Catena e Grillo (*)	Type Type Tipo	Max load Portée max Portata max [Kg]	Length Longueur Lunghezza [m]	Electric pump type <i>Electropompe type</i> Elettropompa tipo								
				KCW100N	KCM100N	KCA100N	KCM150N	KCA150N	KCM200P	KCD200N	KCA200N	KCD250P
	CAT D.14 / GRL D.16	2500	5	●	●	●	●	●	●	●	●	●

(*) = On demand: stainless steel

(*) = Sur demande: acier inox

(*) = Su richiesta: acciaio inox

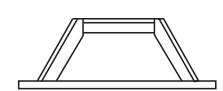
Base frame (dipped galvanized steel) <i>Chassis de soutien (acier galvanisé)</i> Telaio di sostegno (acciaio zincato a caldo)	Type Type Tipo	Weight Poids Peso [Kg]	Electric pump type <i>Electropompe type</i> Elettropompa tipo								
			KCW100N	KCM100N	KCA100N	KCM150N	KCA150N	KCM200P	KCD200N	KCA200N	KCD250P
	TSKM B	20	-	● (4P)	●	●	●	●	●	●	-
	TSK100B/N	18	●	● (2P)	-	-	-	-	-	-	-
	TSK250B	22	-	-	-	-	-	-	-	-	●

Flanged hose connection (dipped galvanized steel) <i>Coude pour tuyauterie souple (acier galvanisé à chaud)</i> Curva flangiata portagomma (acciaio zincato a caldo)	Type Type Tipo	Weight Poids Peso [Kg]	Electric pump type <i>Electropompe type</i> Elettropompa tipo								
			KCW100N	KCM100N	KCA100N	KCM150N	KCA150N	KCM200P	KCD200N	KCA200N	KCD250P
	CFP100	9	●	●	●	-	-	-	-	-	-
	CFP150	18	-	-	-	●	●	-	-	-	-
	CFP200	30	-	-	-	-	-	●	●	●	-
	CFP250	51	-	-	-	-	-	-	-	-	●

Base frame (dipped galvanized steel) Chassis de soutien (acier galvanisé) Telaio di sostegno (acciaio zincato a caldo)	Type Type Tipo	A		B		Weight Poids Peso [Kg]	Electric pump type Electropompe type Elettropompa tipo								
		DN	UNI PN	DN	UNI PN		KCW100N	KCM100N	KCA100N	KCM150N	KCA150N	KCM200P	KCD200N	KCA200N	KCD250P
	TSKIA	150	16	150	16	50	-	● (4P)	●	●	●	-	-	-	-
	TSKMA	200	10	200	10	70	-	-	-	-	-	●	●	●	-
	TSK100A	100	16	100	16	34	●	● (2P)	-	-	-	-	-	-	-
	TSK250A	250	10	250	10	85	-	-	-	-	-	-	-	-	●

(*) = Fixed installation in a dry chamber

(*) = Installation fixe en fosse

(*) = Esecuzione per camera asciutta

Flanged elbow (dipped galvanized steel) Coude bridé (acier galvanisé à chaud) Curva flangiata (acciaio zincato a caldo)	Type Type Tipo	A		B		Weight Poids Peso [Kg]	Electric pump type Electropompe type Elettropompa tipo								
		DN	UNI PN	DN	UNI PN		KCW100N	KCM100N	KCA100N	KCM150N	KCA150N	KCM200P	KCD200N	KCA200N	KCD250P
	CFK100	100	16	100	16	12	●	●	●	-	-	-	-	-	-
	CFK150	150	16	150	16	25,5	-	-	-	●	●	-	-	-	-
	CFK200	200	10	200	10	31	-	-	-	-	-	●	●	●	-
	CFK250	250	10	250	10	43,5	-	-	-	-	-	-	-	-	●

50 Hz motor features (*N/X)
Caractéristiques des moteurs à 50 Hz (*N/X)
Caratteristiche motori a 50 Hz (*N/X)

Poles Pôles Poli	Motor type Moteur type Motore tipo	Motor power Puiss. moteur Potenza motore		Absorption Intensité Assorbimento	Direct starting Démarrage direct Avviamento diretto	Direct starting2 Démarrage direct2 Avviamento diretto2		Starts / hour max Max démarrages / heure Max avviamenti/ora	Degree of intermittence Degré d'intermittence Grado di intermittenza
		P ₁	P ₂	IN (400V)		(Standard)			
		[kW]		[A]		I _S /I _N	Direct Direct Diretto		
6	KC01106..N180..	12,27	11	23,8	6,4	●	●	15	-
	KC01106..P180..	12,27	11	23,8	6,4	●	●	15	-
	KC01506..P180..	16,68	15	33	6,5	●	●	10	-
	KC01956..P200..	21,15	19,5	40,2	6,5	●	●	10	-
4	KC01654..N180..	18	16,5	31,2	5,2	●	●	10	-
	KC01934..N180..	21	19,3	38,8	6,2	●	●	10	-
	KC02104..N180..	22,75	21	39	6,5	●	●	10	-
	KC02304..N180..	25	23	42,4	6	●	●	10	-
	KC02604..N180..	28,17	26	47,2	5,4	●	●	10	-
2	KC02602..N180..	28,26	26	44,6	8,9	●	●	10	-
	KC03502..N180..	37,8	35	57,8	8,7	●	●	10	-

*N = Standard version

*X = Explosion-proof version

P₁ = Power absorbed by the motor

P₂ = Power rated by the motor

I_N = Rated current

I_S = Starting current

- The electric pumps are suitable for S1 continuous service with submersed motor and for S3 intermittent service (see relative degrees of intermittence in the table) with non-submersed motor.

S3 service stands for intermittent service consisting of 10 minute equal cycles of which the previous table indicates the minutes of the cycle during which the motor may operate (eg. : S3 = 25% operation consists of a repetitive sequence of 2,5 minutes operation and 7,5 minutes at a standstill). See standard CEI EN 60034-1

- The electric motors are produced in the following voltage ratings: 400 V ± 10% standard; 230 V ± 10% on request.

Other voltages on request.

*N = Version standard

*X = Version antideflagrante

P₁ = Puissance absorbée par le moteur

P₂ = Puissance restituée par le moteur

I_N = Intensité nominale

I_S = Intensité au démarrage

- L'électropompe est apte à fonctionner en service continu S1 avec le moteur complètement immergé, en service intermittent S3 moteur non immergé (se reporter aux valeurs d'intermittence mentionnées dans le tableau).

Le service S3 indique un fonctionnement intermittent par cycles identiques de 10 minutes. Le tableau ci-dessus indique le temps de marche du moteur en minutes pour 1 cycle de 10 minutes (Ex. : S3 = 25% chaque cycle sera composé de 2,5 minutes de marche et de 7,5 minutes d'arrêt). Voir norme CEI EN 60034-1.

- Les moteurs électriques prévus doivent être alimentés aux tensions nominales suivantes: 400 V ± 10% standard; 230 V ± 10% sur demande.

Tensions différentes sur demande.

*N = Versione standard

*X = Versione antideflagrante

P₁ = Potenza assorbita motore

P₂ = Potenza resa dal motore

I_N = Corrente nominale

I_S = Corrente di avviamento

- Le elettropompe sono atte a funzionare in servizio continuo S1 con motore immerso, in servizio intermittente S3 con motore non immerso (vedi relativi gradi di intermittenza nella tabella).

Il servizio S3 sta ad indicare un funzionamento intermittente composto da cicli tutti uguali di 10 minuti di cui si indicano i minuti del ciclo in cui il motore può funzionare (Es. : S3 = 25% il funzionamento è composto da una sequenza ripetitiva di 2,5 minuti di funzionamento e di 7,5 minuti di sosta). Vedi norma CEI EN 60034-1.

- I motori elettrici sono previsti per essere alimentati alle seguenti tensioni nominali di rete: 400 V ± 10% standard; 230 V ± 10% a richiesta.

Tensioni diverse su richiesta.

K+

DN 150÷350



Performance ranges
Champs de performance
Campi di prestazione

- KCM150R(N)
- KCM250R(N)
- KCM250Z(N)
- KCD300R(N)
- KCD300Z(N)
- KCD350R(N)

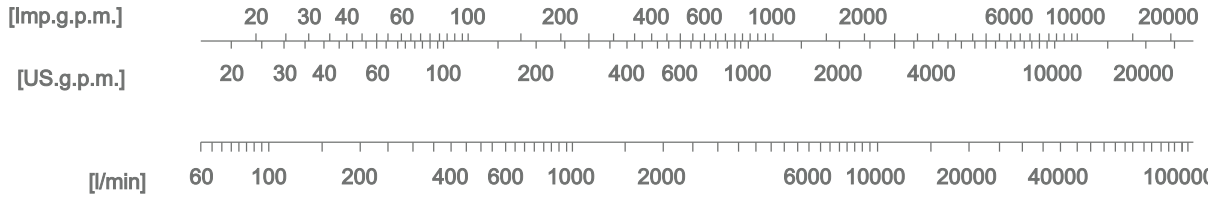
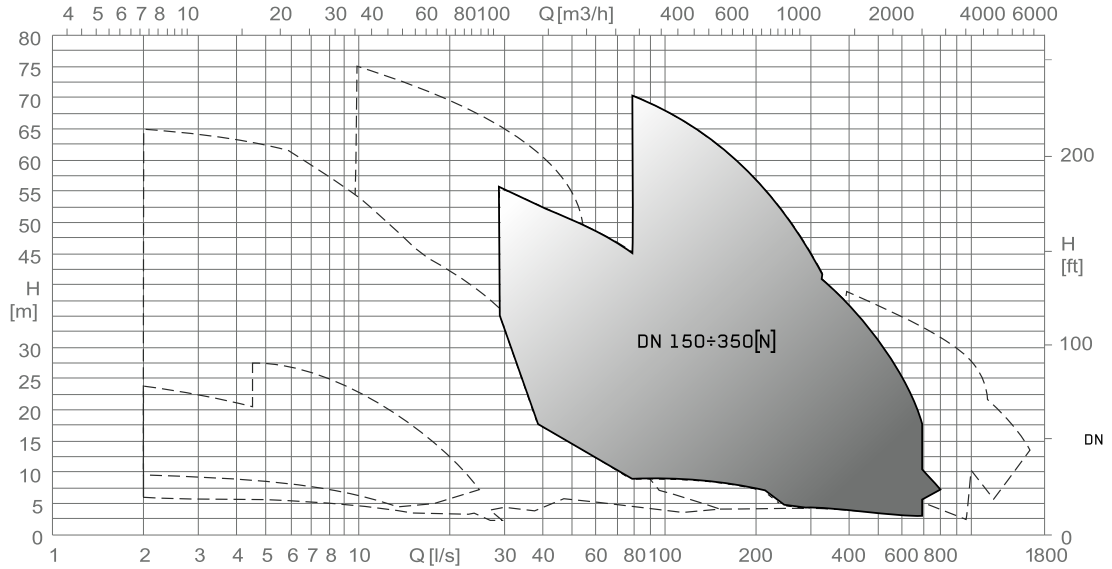

K+

DN 150÷350

caprari

KCM250Z(N)
KCD300Z(N)
KCD350R(N)..8P

Construction and materials
Construction et matériaux
Costruzione e materiali

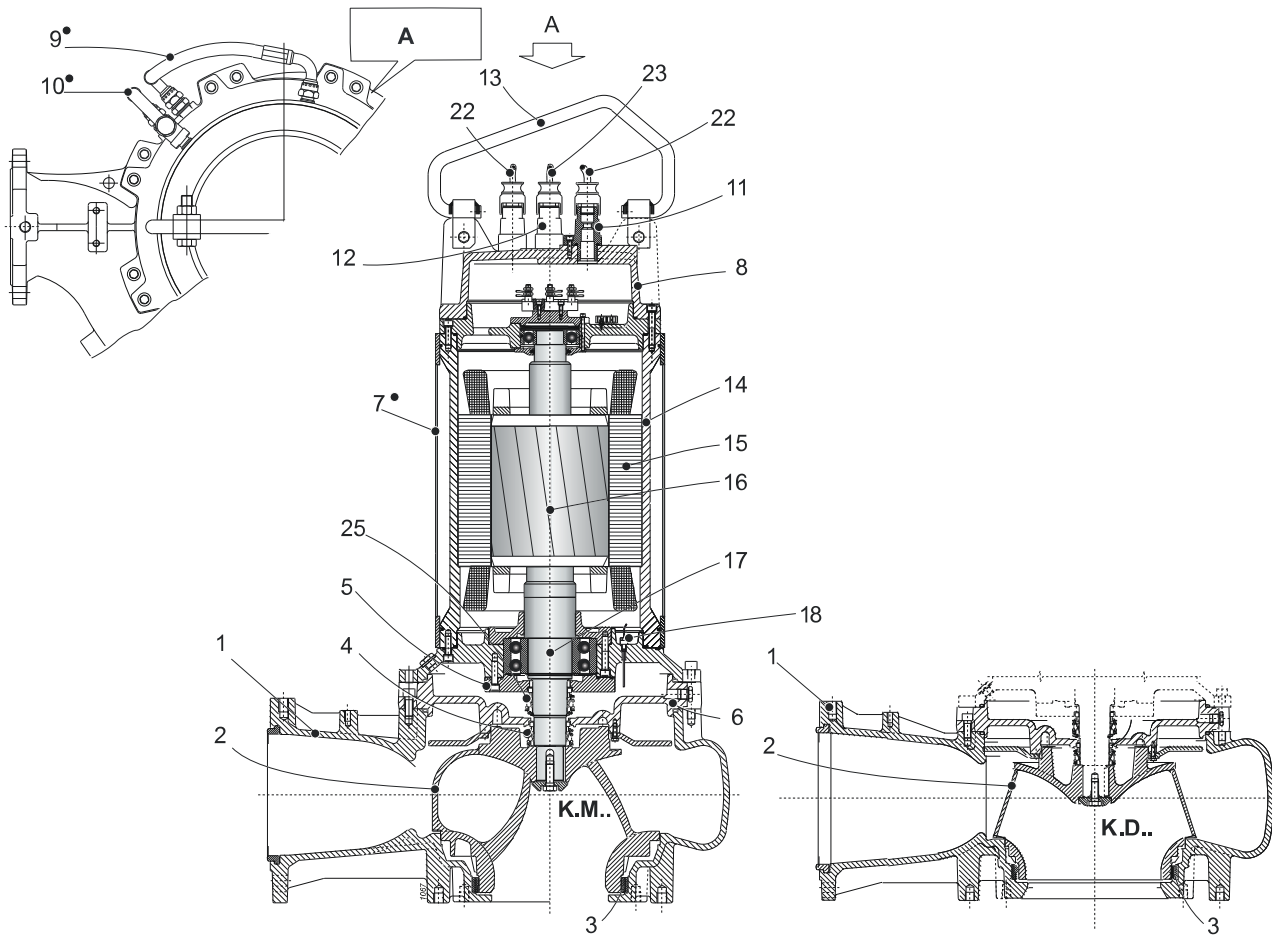

Pos.	Parts	Materials	Nomenclature	Matériaux	Nomenclatura	Materiale
1	Delivery body	Cast iron	Corps de refoulement	Fonte grise	Corpo mandata	Ghisa grigia
2	Impeller	Cast iron	Roue	Fonte grise	Girante	Ghisa grigia
3	Impeller wear ring	Steel/Rubber	Bague d'usure	Acier/Caoutchouc	Anello sede girante	Acciaio/Gomma
4	Mechanical seal on pump side	Silicon carbide/silicon carbide	Garniture mécanique côté pompe	Carbure de silicium/ carbure de silicium	Tenuta meccanica lato pompa	Carburo di silicio/ carburo di silicio
5	Support bearing	Nodular cast iron	Support de roulement	Fonte sphéroïdale	Supporto cuscinetto	Ghisa sferoidale
6	Oil box	Cast iron	Chambre à huile	Fonte grise	Scatola olio	Ghisa grigia
7•	Cooling jacket	Stainless steel	Chemise	Acier inox	Mantello	Acciaio inox
8	Head cover	Cast iron	Couvercle tête	Fonte grise	Coperchio testata	Ghisa grigia
9 - 10•	Cooling pipe	Stainless steel/PTFE	Tuyau de refroidissement	Acier inox/PTFE	Tubo di raffreddamento	Acciaio inox/PTFE
11 - 12	Cable clamp	Cast iron	Presse-étoupe	Fonte grise	Pressacavo	Ghisa grigia
13	Handle	Stainless steel	Poignée	Acier inox	Maniglia	Acciaio inox
14	Motor casing	Cast iron	Enveloppe du moteur	Fonte grise	Carcassa motore	Ghisa grigia
15	Stator	Electrical steel	Stator	Tôle magnétique	Statore	Lamierino magnetico
16	Rotor	Electrical steel	Rotor	Tôle magnétique	Rotore	Lamierino magnetico
17	Shaft	Stainless steel	Arbre	Acier inox	Albero	Acciaio inox
18	Conductivity probe	-	Sondes de conductivité	-	Sonda di conduttività	-
22	Round power cable	-	Câble rond d'alimentation	-	Cavo tondo di alimentazione	-
23	Round auxiliary cable	-	Câble rond auxiliaire	-	Cavo tondo ausiliario	-
25	Mechanical seal on motor side	Stainless steel/graphite	Garniture mécanique côté moteur	Acier inox/graphite	Tenuta meccanica lato motore	Acciaio inox/grafite

• Cooling system components (Version .../R)

Screws and nuts in stainless steel.
Available version with AISI 316 stainless steel impeller.

• Composant pour version avec système de refroidissement (Version .../R)

Vis et écrous en acier inox
Disponibile version Avec roue en acier inox AISI 316.

• Componenti sistema di raffreddamento (Versione .../R)

Viti e dadi in acciaio inox
Disponibile versione con girante in acciaio inox AISI 316.

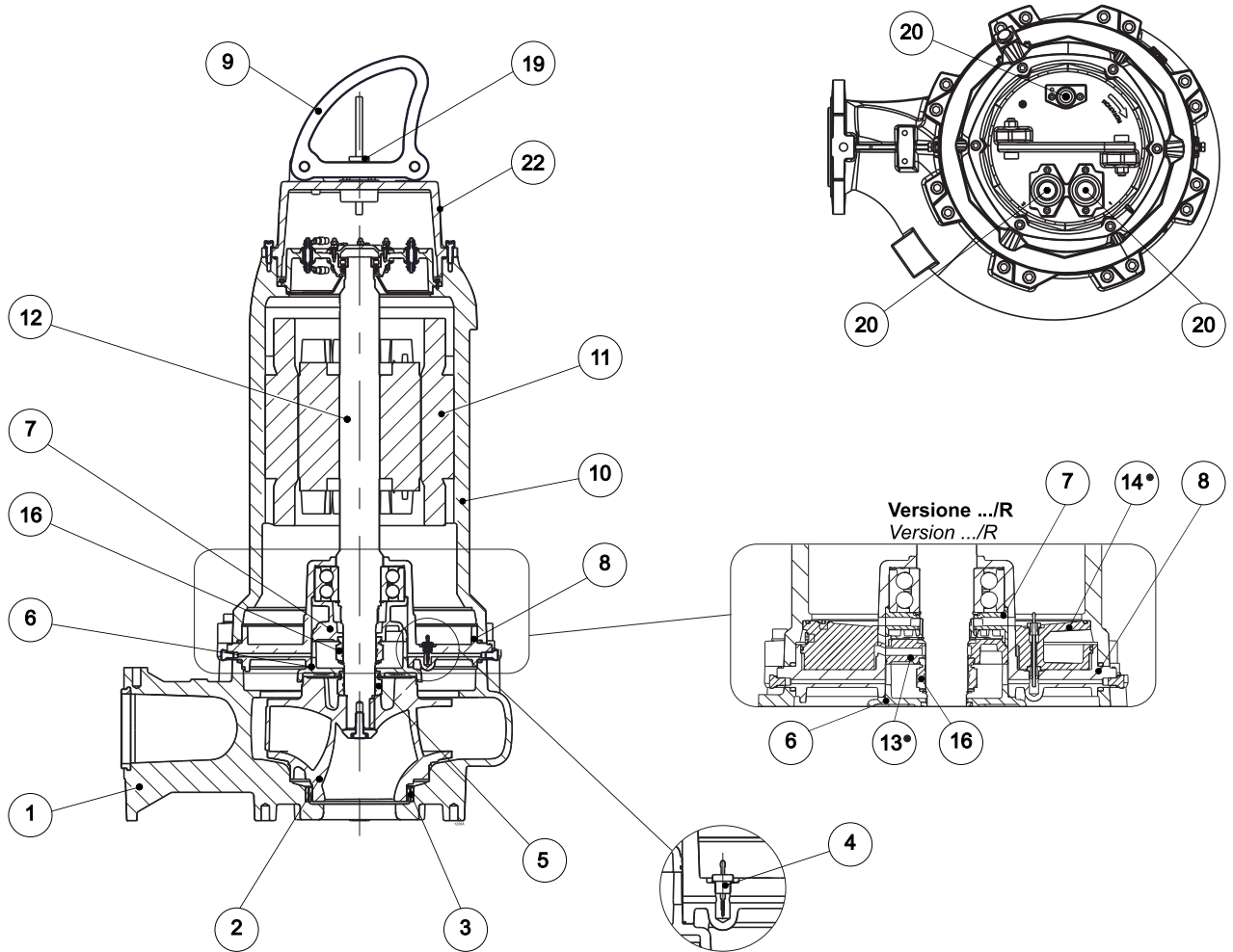

Pos.	Parts	Materials	Nomenclature	Matériaux	Nomenclatura	Materiale
1	Delivery body	Cast iron	Corps de refoulemen	Fonte grise	Corpo mandata	Ghisa grigia
2	Impeller	Cast iron	Roue	Fonte grise	Girante	Ghisa grigia
3	Ring impeller seat	Steel/Rubber	Bague d'usure	Acier/Caoutchouc	Anello sede girante	Acciaio/Gomma
4	Conductivity probe	-	Sondes de conductivité	-	Sonda di conduttività	-
5	Mechanical seal on pump side	Stainless steel/graphite	Garniture mécanique côté pompe	Acier inox/graphite	Tenuta meccanica lato pompa	Acciaio inox/grafite
6	Flange for mechanical seal	Nodular cast iron	Bride porte garniture mécanique	Fonte sphéroïdale	Flangia porta tenuta meccanica	Ghisa sferoidale
7	Support bearing	Cast iron	Support de roulement	Fonte grise	Supporto cuscinetto	Ghisa grigia
8	Oil box	Cast iron	Chambre à huile	Fonte grise	Scatola olio	Ghisa grigia
9	Handle	Stainless steel	Poignée	Acier inox	Maniglia	Acciaio inox
10	Motor casing	Cast iron	Enveloppe du moteur	Fonte grise	Carcassa motore	Ghisa grigia
11	Stator	Electrical steel	Stator	Tôle magnétique	Statore	Lamierino magnetico
12	Complete shaft with rotor	Stainless steel/ Magnetic steel	Arbre avec rotor	Acier inox/Tôle magnétique	Albero completo di rotore	Acciaio inox/ Lamierino magnetico
13●	Flange for mechanical seal	Nodular cast iron	Bride porte garniture mécanique	Fonte sphéroïdale	Flangia porta tenuta meccanica	Ghisa sferoidale
14●	Spacer sleeve	Cast iron	Entretoise	Fonte grise	Distributore	Ghisa grigia
16	Mechanical seal on motor side	Ceramic/graphite	Garniture mécanique côté moteur	Céramique/graphite	Tenuta meccanica lato motore	Ceramica/grafite
19	Cable clamp	Cast iron	Presse-étoupe	Fonte grise	Pressacavo	Ghisa grigia
20	Round power cable	-	Câble rond d'alimentation	-	Cavo tondo di alimentazione	-
22	Head cover	Cast iron	Couvercle tête	Fonte grise	Coperchio testata	Ghisa grigia

● Cooling system components (Version .../R)

Screws and nuts in stainless steel.

Available version with AISI 316 stainless steel impeller.

● Composant pour version avec système de refroidissement (Version .../R)

Vis et écrous en acier inox

Disponible version Avec roue en acier inox AISI 316.

● Componenti sistema di raffreddamento (Versione .../R)

Viti e dadi in acciaio inox

Disponibile versione con girante in acciaio inox AISI 316.

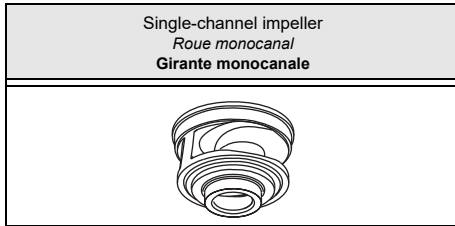

Type Type Tipo	KCM150R...+...42N3	
Thermal probes Sondes thermiques Sonde termiche	Yes Oui Sì	
Conductivity probe Sonde de conductivité Sonda di conduttività	Yes Oui Sì	

Version cable (1)
Version câble (1)
Cavo Versione (1)

Electric pump type Electropompe type Elettropompa tipo	Power supply Alimentazione	Auxiliary Auxiliaire Ausiliario
KCM150RL+034042N3	2x(4x10)x10	1x(4x1,5)x10
KCM150RG+042042N3	2x(4x10)x10	1x(4x1,5)x10
KCM150RD+051042N3	2x(4x10)x10	1x(4x1,5)x10
KCM150RA+062042N3	2x(4x16)x10	1x(4x1,5)x10

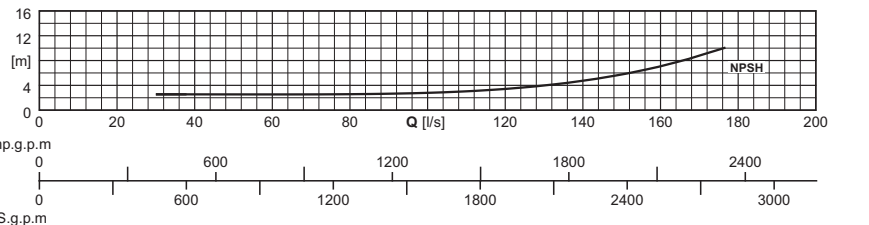
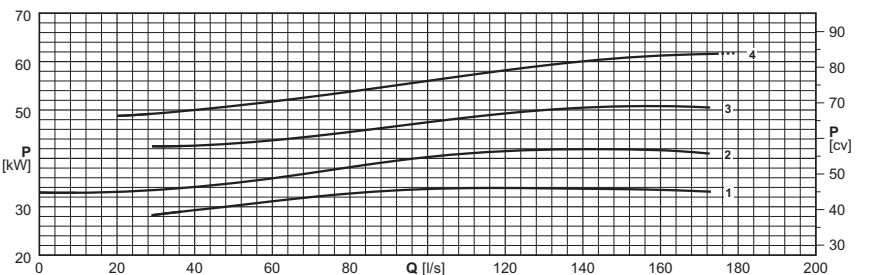
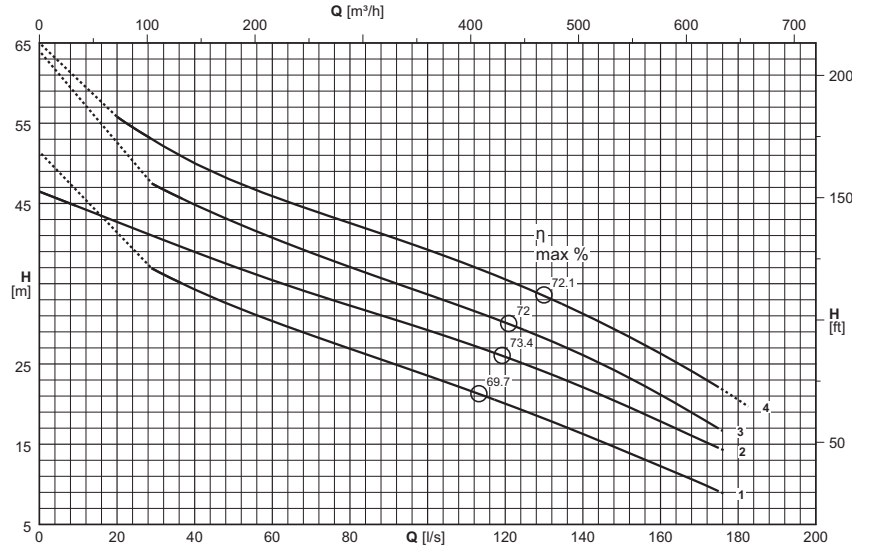

(1) = n°. of cables x (n°. of wires each cable x size [mm²]) x cable length [m] - Câble NSSHOU-J

Cable length exceeding 10 m on request

(1) = n°. câbles x (n°. conducteurs câble x section [mm²]) x longueur câble [m] - Câble NSSHOU-J

Sur demande longueur de câble supérieure à 10 m

(1) = n°. cavi x (n°. conduttori per cavo x sezione [mm²]) x lunghezza cavo [m] - Cavo NSSHOU-J

Lunghezza cavo superiore a 10 m - su richiesta

Electric pump type Electropompe type Elettropompa tipo	Curve Courbe Curva	Motor power Puiss. moteur Potenza motore	Capacity Débit Portata																			
			[l/s]	0	10	15	20	25	30	35	40	45	50	60	70	80	90	100	125	150	175	182
		P ₂	[m ³ /h]	0	36	54	72	90	108	126	144	162	180	216	252	288	324	360	450	540	630	655,2
	(N°)	[kW]	Head Hauteur Prevalenza																			
KCM150RL+034042N3	1	34	[m]	46,4					36,7	35,5	34,3	33,2	32,2	30,3	28,6	26,9	25,2	23,5	19,1	14,3	9,1	
KCM150RG+042042N3	2	42	[m]	46,5	44,6	43,6	42,7	41,8	40,8	39,9	39	38,1	37,2	35,5	33,8	32,3	30,8	29,2	25	20	14,5	
KCM150RD+051042N3	3	51	[m]	59					47,2	46	44,9	43,8	42,7	40,7	38,9	37,1	35,4	33,7	29,2	23,7	16,9	
KCM150RA+062042N3	4	62	[m]	62,4			55,8	54,2	52,7	51,3	50,1	48,9	47,9	45,9	44,2	42,6	40,9	39,2	34,5	28,9	22,1	19,9
NPSH _R			[m]			2,6	2,6	2,5	2,5	2,5	2,5	2,5	2,5	2,5	2,5	2,6	2,7	2,9	3,7	5,8	9,8	11,1

P₂ = Power rated by the motor
Performance tolerance as per:
UNI/ISO 9906 Grade 3B

(2) For models in the explosion-proof version KCM150R(X)

For motor performances specification see page "motor features"

For the accessories specification see page "Accessories"

P₂ = Puissance restituée par le moteur
Tolérances sur les performances selon normes:
UNI/ISO 9906 Niveau 3B

(2) Pour les modèles version antidéflagrante KCM150R(X)

Pour caractéristiques techniques moteurs voir page "Caractéristiques des moteurs"

Pour les accessoires voir page "Accessories"

P₂ = Potenza resa dal motore

Tolleranze sulle prestazioni secondo norme:
UNI/ISO 9906 Grado 3B

(2) Versione antideflagrante vedere KCM150R(X)

Per caratteristiche motori vedere pagina "caratteristiche motori"

Per accessori vedere pagina accessori

KCM150R (N)

Poles
Pôles
Poli **4**

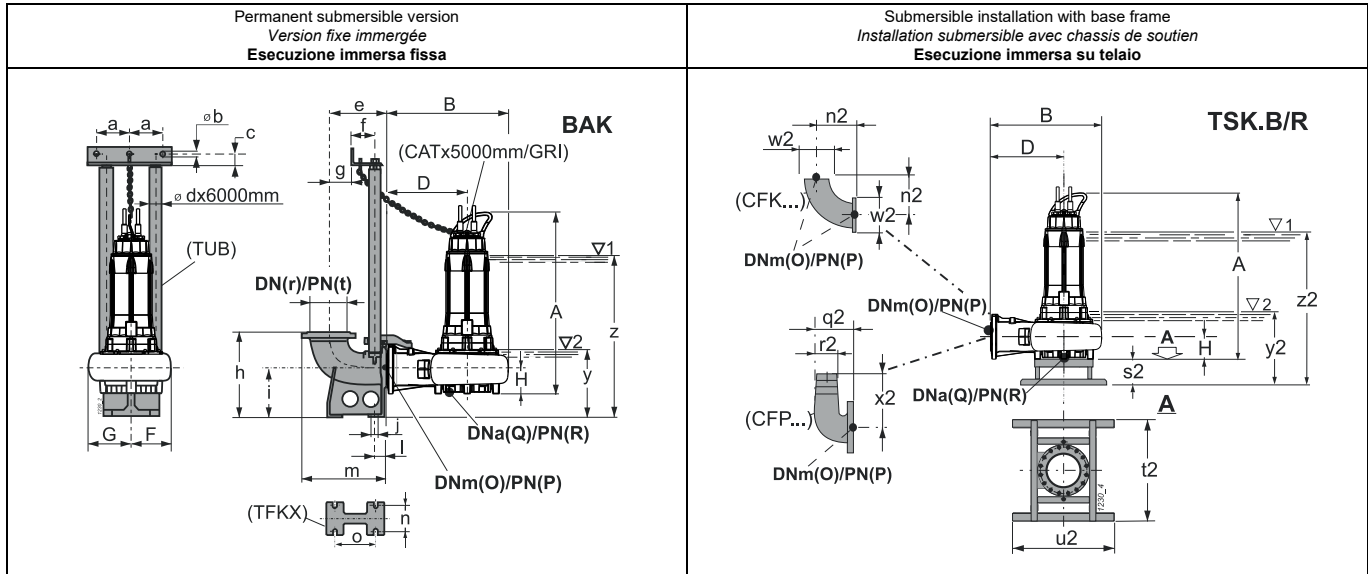

For fixed installation in a dry chamber - vertical (R)
Pour installation fixe en fosse sèche - verticale (R)
Esecuzione per camera asciutta - verticale (R)

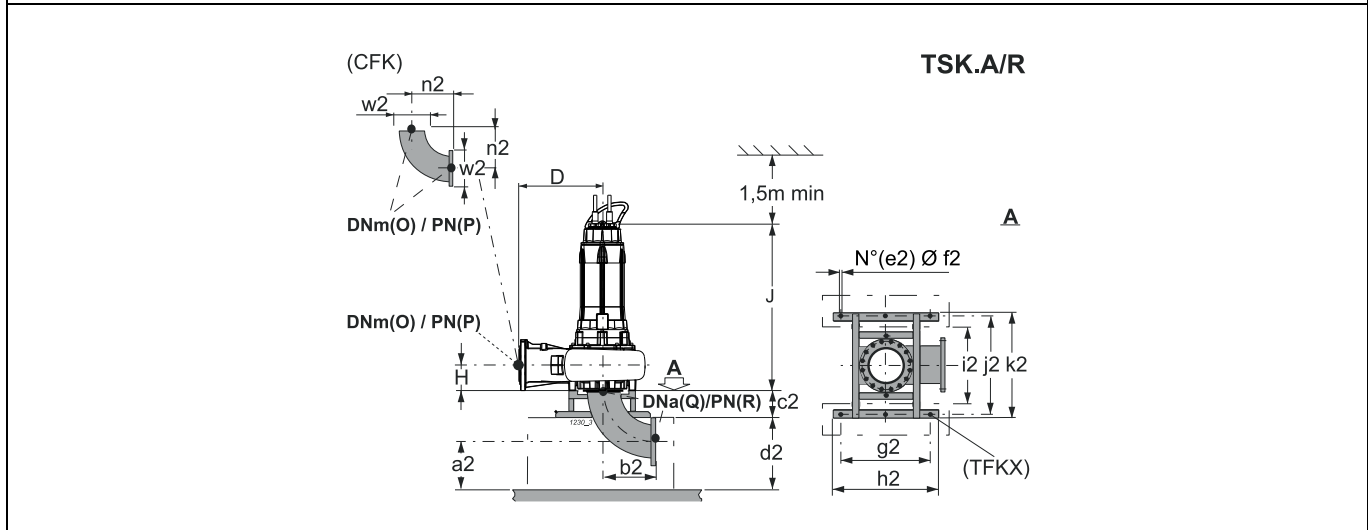

Type Type Tipo	Free passage Passage libre Passaggio Libero	Weight Poids Peso	[mm]												Accessories Accessoires Accessori					
			A	B	D	F	G	H	J	O	P	Q	R	BAK.	TSK.A/R	TSK.B/R				
KCM150RL+034042N3	Ø 102	712	1569	825	500	305	365	195	-	150	16	150	16	M/I 3"	-	150				
KCM150RL+034042N3/R	Ø 102	750,3	1569	825	500	305	365	195	1335	150	16	150	16	M/I 3"	150	-				
KCM150RG+042042N3	Ø 102	715,4	1569	825	500	305	365	195	-	150	16	150	16	M/I 3"	-	150				
KCM150RG+042042N3/R	Ø 102	753,7	1569	825	500	305	365	195	1335	150	16	150	16	M/I 3"	150	-				
KCM150RD+051042N3	Ø 102	748	1569	825	500	305	365	195	-	150	16	150	16	M/I 3"	-	150				
KCM150RD+051042N3/R	Ø 102	786,3	1569	825	500	305	365	195	1335	150	16	150	16	M/I 3"	150	-				
KCM150RA+062042N3	Ø 102	802	1623	825	500	305	365	195	-	150	16	150	16	M/I 3"	-	150				
KCM150RA+062042N3/R	Ø 102	840,3	1623	825	500	305	365	195	1389	150	16	150	16	M/I 3"	150	-				
BAK.			a	b	c	d	e	f	g	h	i	j	l	m	n	o	r	t	y	z
BAKM/I 3"			157,5	12,5	35	3"	385	117	180	540	290	24	80	555	210	280	200	10	472	1292
TSK.A/R			a2	b2	c2	d2	e2	f2	g2	h2	i2	j2	k2	n2	w2					
TSK150A/R			285	395	280	400	6	22	850	1000	740	935	1000	395	285					
TSK.B/R			n2	q2	r2	s2	t2	u2	w2	x2	y2	z2								
TSK150B/R			395	315	150	280	1000	1000	285	380	657	1477								

(3) z = Minimum submergence depth for motor without casing with continuous duty S1 (NPSHR permitting)
y = Minimum submergence depth for motor without casing with intermittent duty S3 (NPSHR permitting)

(3) z = Immersion minimum pour moteur sans chemise en service continu S1 (compatible avec le NPSHR)
y = Immersion minimum pour moteur sans chemise en service intermittent S3 (compatible avec le NPSHR)

(3) z = Immersion minima per motore senza mantello in funzione continuo S1 compatibilmente con l'NPSHR
y = Immersione minima con motore senza mantello in funzione intermittente S3 compatibilmente con l'NPSHR

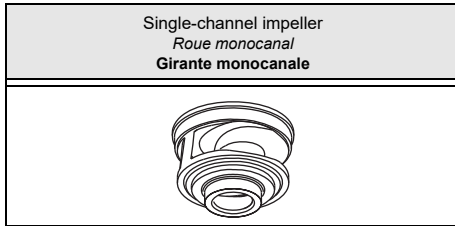

Type <i>Type</i> Tipo	KCM250Z...+...82N1	
Thermal probes <i>Sondes thermiques</i> Sonde termiche	Yes <i>Oui</i> SI	
Conductivity probe <i>Sonde de conductivité</i> Sonda di conduttività	Yes <i>Oui</i> SI	

Version cable (1)
Version câble (1)
Cavo Versione (1)

Electric pump type <i>Electropompe type</i> Elettropompa tipo	Power supply <i>Alimentation</i> Alimentazione	Auxiliary <i>Auxiliaire</i> Ausiliario
KCM250ZA+021082N1	2x(4x6)x10	1x(5x1,5)x10

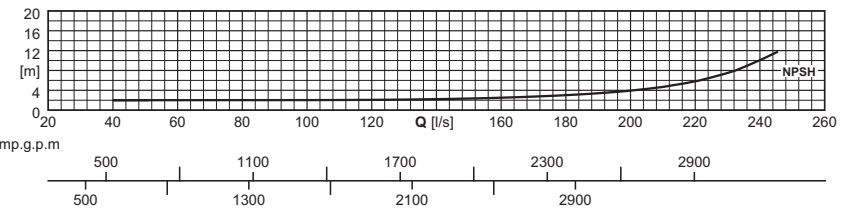
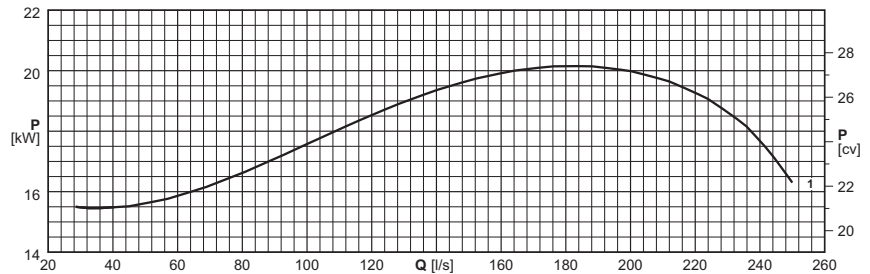
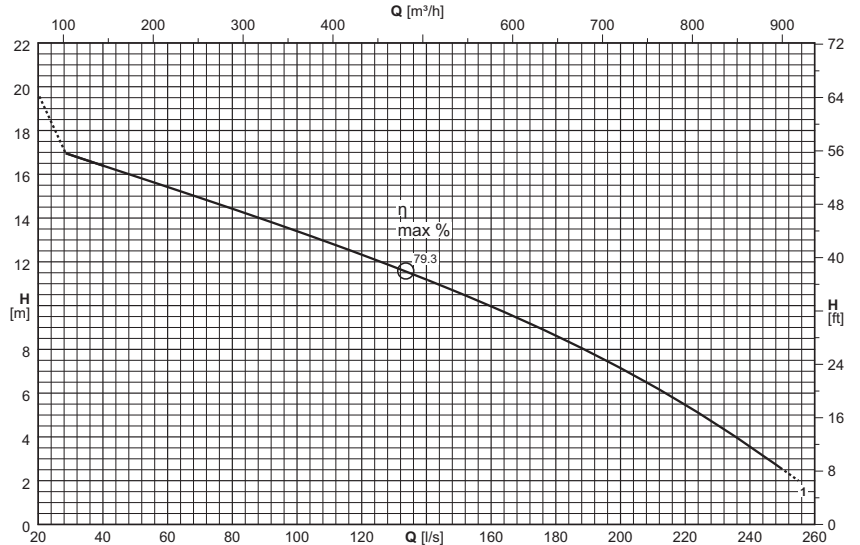

(1) = n°. of cables x (n°. of wires each cable x size [mm²]) x cable length [m] - *Cable H07RN-F (OZOFLEX Plus)*
Cable length exceeding 10 m on request

(1) = n°. câbles x (n°. conducteurs câble x section [mm²]) x longueur câble [m] - *Câble H07RN-F (OZOFLEX Plus)*
Sur demande longueur de câble supérieure à 10 m

(1) = n°. cavi x (n°. conduttori per cavo x sezione [mm²]) x lunghezza cavo [m] - *Cavo H07RN-F (OZOFLEX Plus)*
Lunghezza cavo superiore a 10 m - su richiesta

Electric pump type <i>Electropompe type</i> Elettropompa tipo	Curve <i>Courbe</i> Curva	Motor power <i>Puiss. moteur</i> Potenza motore	Capacity <i>Debit</i> Portata																				
			[l/s]	0	30	35	40	45	50	60	70	80	90	100	125	150	175	200	225	250	255		
KCM250ZA+021082N1	(N°)	[kW]	P ₂	[m ³ /h]	0	108	126	144	162	180	216	252	288	324	360	450	540	630	720	810	900	918	
						Head <i>Hauteur</i> Prevalenza																	
NPSH _R			[m]	19,7	16,9	16,6	16,4	16,2	15,9	15,4	14,9	14,4	13,9	13,4	12	10,6	9	7,1	5	2,5	2		
			[m]		2	2	2	2	2	2	2	2	2	2	2	2,1	2,3	2,9	4	6,7	14,2	16,5	

P₂ = Power rated by the motor

Performance tolerance as per:
UNI/ISO 9906 Grade 3B

(2) For models in the explosion-proof version KCM250Z(X)

For motor performances specification see page "motor features"

For the accessories specification see page "Accessories"

P₂ = Puissance restituée par le moteur

Tolérances sur les performances selon normes:
UNI/ISO 9906 Niveau 3B

(2) Pour les modèles version antidéflagrante KCM250Z(X)

Pour caractéristiques techniques moteurs voir page "Caractéristiques des moteurs"

Pour les accessoires voir page "Accessories"

P₂ = Potenza resa dal motore

Tolleranze sulle prestazioni secondo norme:
UNI/ISO 9906 Grado 3B

(2) Versione antidéflagrante vedere KCM250Z(X)

Per caratteristiche motori vedere pagina "caratteristiche motori"

Per accessori vedere pagina accessori

(N)

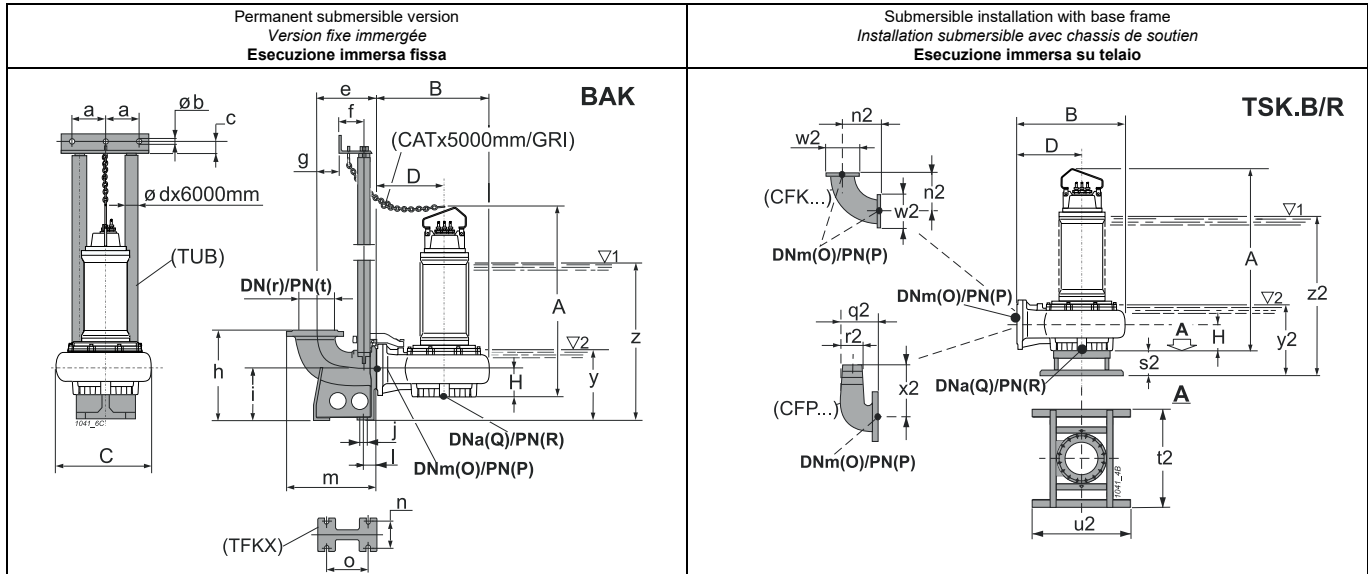

For fixed installation in a dry chamber - vertical (R)
Pour installation fixe en fosse sèche - verticale (R)
Esecuzione per camera asciutta - verticale (R)

For fixed installation in a dry chamber - horizontal (R)
Pour installation fixe en fosse sèche - horizontale (R)
Esecuzione per camera asciutta - orizzontale (R)

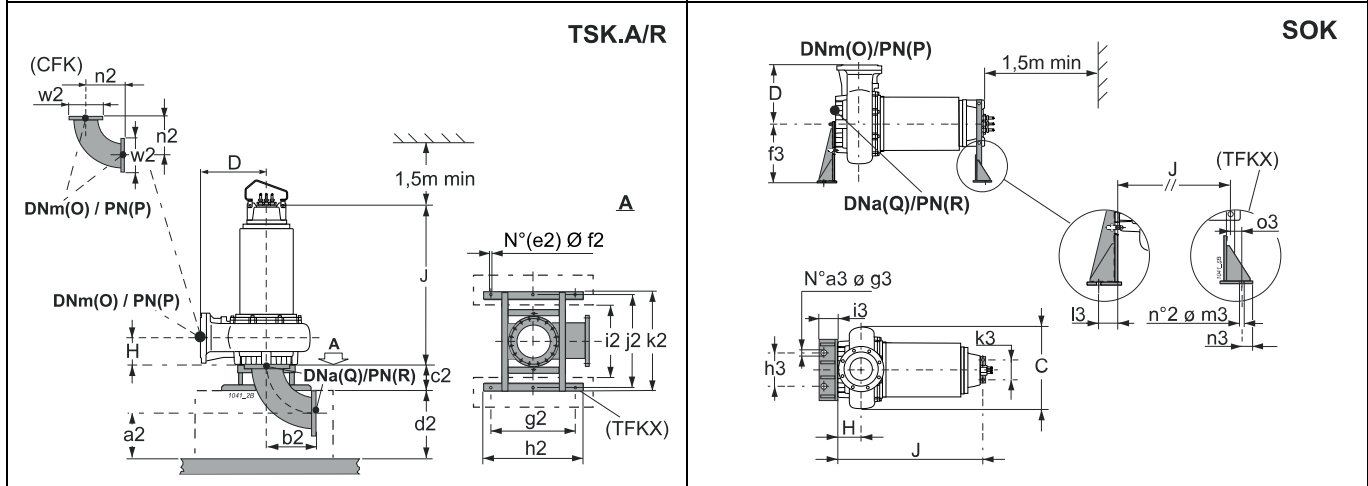

Type Type Tipo	Free passage Passage libre Passaggio Libero	Weight Poids Peso	A	B	C	D	H	J	O	P	Q	R	Accessories Accessoires Accessori					
			[mm]	[mm]	[mm]	[mm]	[mm]	[mm]	[mm]	[mm]	[mm]	[mm]	[mm]	[mm]	BAK.	SOK.	TSK.A/R	TSK.B/R
KCM250ZA+021082N1	Ø 163	653	1612,5	935	735	570	220	-	250	10	250	10	300/250 3"	-	-	-	350	
KCM250ZA+021082N1/R	Ø 163	668	1612,5	935	735	570	220	1335	250	10	250	10	300/250 3"	350-200	250	-	-	
BAK.	a	b	c	d	e	f	g	h	i	j	l	m	n	o	r	t	y	z
BAK300/250 3"	157,5	12,5	35	3"	450	117	245	700	400	24	85	673	310	425	300	10	585	1330
SOK.	a3	f3	g3	h3	i3	k3	l3	m3	n3	o3								
SOK350-200	3	530	22	500	160	270	100	22	40	85								
TSK.A/R	a2	b2	c2	d2	e2	f2	g2	h2	i2	j2	k2	n2	w2					
TSK250A/R	295	385	280	400	6	22	850	1000	740	935	1000	385	395					
TSK.B/R	n2	q2	r2	s2	t2	u2	w2	x2	y2	z2								
TSK350B/R	385	525	250	280	1000	1000	395	575	685	1430								

(3) z = Minimum submergence depth for motor without casing with continuous duty S1 (NPSHR permitting)
y = Minimum submergence depth for motor without casing with intermittent duty S3 (NPSHR permitting)

(3) z = Immersion minimum pour moteur sans chemise en service continu S1 (compatible avec le NPSHR)
y = Immersion minimum pour moteur sans chemise en service intermittent S3 (compatible avec le NPSHR)

(3) z = Immersione minima per motore senza mantello in funzione continuo S1 compatibilmente con l'NPSHR
y = Immersione minima con motore senza mantello in funzione intermittente S3 compatibilmente con l'NPSHR

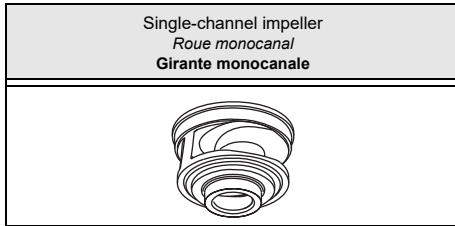

Type Type Tipo	KCM250R...+...62N3	
Thermal probes Sondes thermiques Sonda termiche	Yes Oui SI	
Conductivity probe Sonde de conductivité Sonda di conduttività	Yes Oui SI	

Version cable (1)
Version câble (1)
Cavo Versione (1)

Electric pump type Electropompe type Elettropompa tipo	Power supply Alimentazione	Auxiliary Auxiliaire Ausiliario
KCM250RL+025062N3	2x(4x10)x10	1x(4x1,5)x10
KCM250RG+034062N3	2x(4x10)x10	1x(4x1,5)x10
KCM250RD+042062N3	2x(4x16)x10	1x(4x1,5)x10
KCM250RA+051062N3	2x(4x25)x10	1x(4x1,5)x10

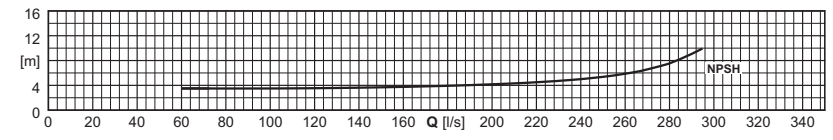
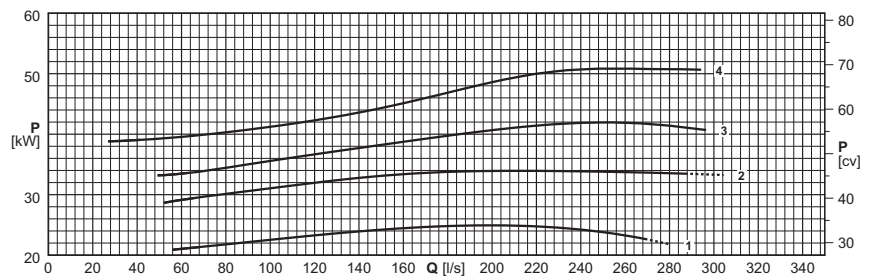
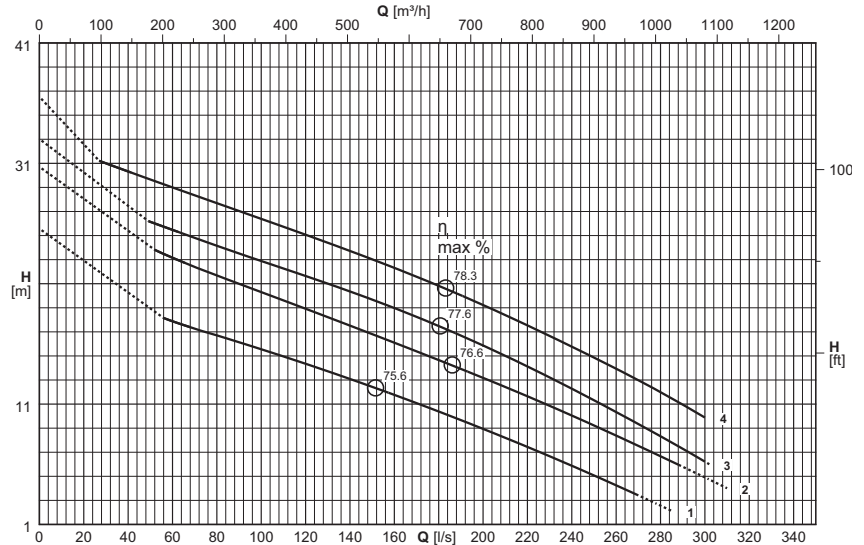

(1) = n°. of cables x (n°. of wires each cable x size [mm²]) x cable length [m] - Câble NSSHOU-J

Cable length exceeding 10 m on request

(1) = n°. câbles x (n°. conducteurs câble x section [mm²]) x longueur câble [m] - Câble NSSHOU-J

Sur demande longueur de câble supérieure à 10 m

(1) = n°. cavi x (n°. conduttori per cavo x sezione [mm²]) x lunghezza cavo [m] - Cavo NSSHOU-J

Lunghezza cavo superiore a 10 m - su richiesta

Electric pump type Electropompe type Elettropompa tipo	Curve Courbe Curva	Motor power Puiss. moteur Potenza motore	Capacity Débit Portata																				
			[l/s]	0	30	35	40	45	50	60	70	80	90	100	125	150	175	200	225	250	275	300	310
		P ₂	[m³/h]	0	108	126	144	162	180	216	252	288	324	360	450	540	630	720	810	900	990	1080	1116
	(N°)	[kW]	Head Hauteur Prevalenza																				
			[m]	24,6						17,9	17,3	16,7	16,1	15,6	14	12,4	10,7	8,9	7,1	5,1	3		
KCM250RL+025062N3	1	25	[m]	24,6						17,9	17,3	16,7	16,1	15,6	14	12,4	10,7	8,9	7,1	5,1	3		
KCM250RG+034062N3	2	34	[m]	29,7						23,2	22,4	21,7	21	20,3	18,6	16,8	15	13,2	11,3	9,2	7,1	4,9	4
KCM250RD+042062N3	3	42	[m]	32					26,1	25,5	24,8	24,2	23,5	22,9	21,3	19,7	17,9	15,9	13,7	11,3	8,8	6,2	
KCM250RA+051062N3	4	51	[m]	35,5	31	30,7	30,3	30	29,7	29	28,3	27,7	27	26,4	24,7	23	21,2	19,2	17,1	14,9	12,5	9,9	
NPSH _R			[m]							3,5	3,5	3,5	3,5	3,5	3,6	3,7	3,9	4,2	4,7	5,4	7	11,6	14,8

P₂ = Power rated by the motor
Performance tolerance as per:
UNI/ISO 9906 Grade 3B

(2) For models in the explosion-proof version KCM250R(X)
For motor performances specification see page "motor features"

For the accessories specification see page "Accessories"

P₂ = Puissance restituée par le moteur
Tolérances sur les performances selon normes:
UNI/ISO 9906 Niveau 3B

(2) Pour les modèles version antidéflagrante KCM250R(X)
Pour caractéristiques techniques moteurs voir page "Caractéristiques des moteurs"

Pour les accessoires voir page "Accessories"

P₂ = Potenza resa dal motore
Tolleranze sulle prestazioni secondo norme:
UNI/ISO 9906 Grado 3B

(2) Versione antideflagrante vedere KCM250R(X)
Per caratteristiche motori vedere pagina "caratteristiche motori"

Per accessori vedere pagina accessori

KCM250R (N)

Poles
Pôles
Poli **6**

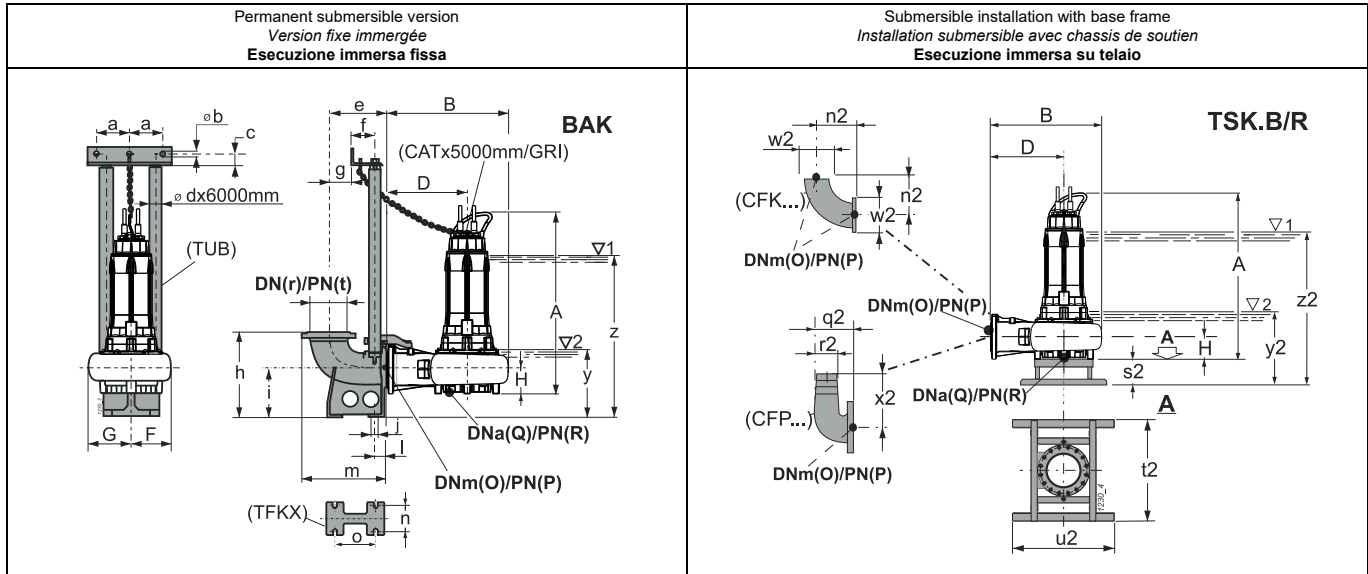

For fixed installation in a dry chamber - vertical (R)
Pour installation fixe en fosse sèche - verticale (R)
Esecuzione per camera asciutta - verticale (R)

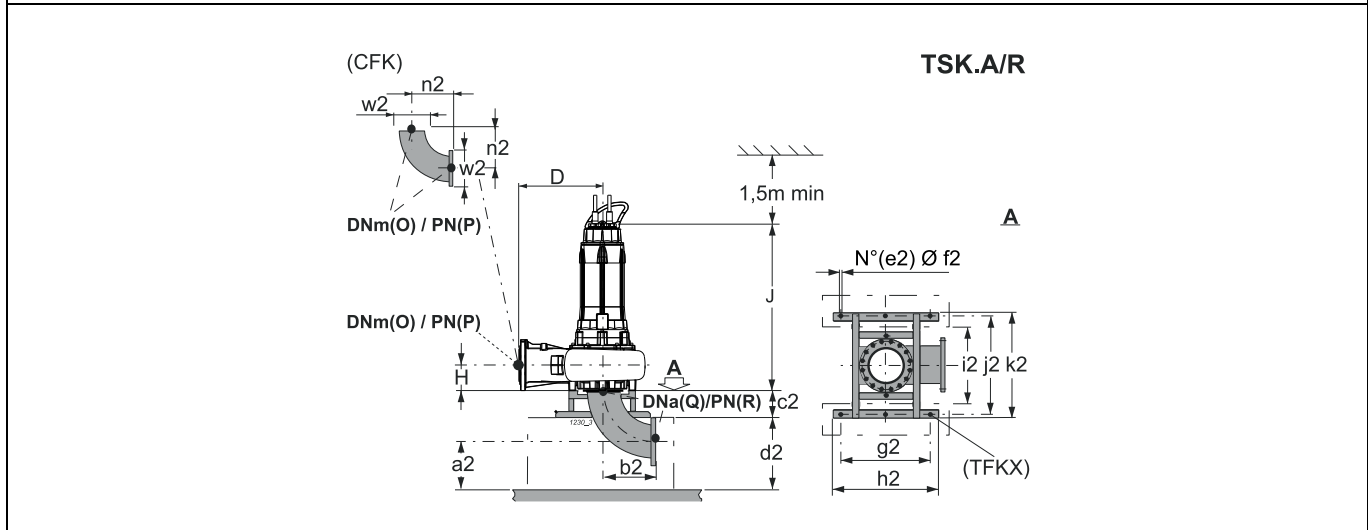

Type Type Tipo	Free passage Passage libre Passaggio Libero	Weight Poids Peso	A	B	D	F	G	H	J	O	P	Q	R	Accessories Accessoires Accessori						
														BAK.	TSK.A/R	TSK.B/R				
	[mm]	[kg]	[mm]																	
KCM250RL+025062N3	Ø 163	788,5	1622	935	570	330	405	220	-	250	10	250	10	300/250 3"	-	350				
KCM250RL+025062N3/R	Ø 163	826,8	1622	935	570	330	405	220	1388	250	10	250	10	300/250 3"	250	-				
KCM250RG+034062N3	Ø 163	794	1622	935	570	330	405	220	-	250	10	250	10	300/250 3"	-	350				
KCM250RG+034062N3/R	Ø 163	832,3	1622	935	570	330	405	220	1388	250	10	250	10	300/250 3"	250	-				
KCM250RD+042062N3	Ø 163	870	1676	935	570	330	405	220	-	250	10	250	10	300/250 3"	-	350				
KCM250RD+042062N3/R	Ø 163	908,3	1676	935	570	330	405	220	1442	250	10	250	10	300/250 3"	250	-				
KCM250RA+051062N3	Ø 163	970	1709	935	570	330	405	220	-	250	10	250	10	300/250 3"	-	350				
KCM250RA+051062N3/R	Ø 163	1008,3	1709	935	570	330	405	220	1475	250	10	250	10	300/250 3"	250	-				
BAK.			a	b	c	d	e	f	g	h	i	j	l	m	n	o	r	t	y	z
BAK300/250 3"			157,5	12,5	35	3"	450	117	245	700	400	24	85	673	310	425	300	10	610	1463
TSK.A/R			a2	b2	c2	d2	e2	f2	g2	h2	i2	j2	k2	n2	w2					
TSK250A/R			295	385	280	400	6	22	850	1000	740	935	1000	385	395					
TSK.B/R			n2	q2	r2	s2	t2	u2	w2	x2	y2	z2								
TSK350B/R			385	525	250	280	1000	1000	395	575	710	1563								

(3) z = Minimum submergence depth for motor without casing with continuous duty S1 (NPSHR permitting)
y = Minimum submergence depth for motor without casing with intermittent duty S3 (NPSHR permitting)

(3) z = Immersion minimum pour moteur sans chemise en service continu S1 (compatible avec le NPSHR)
y = Immersion minimum pour moteur sans chemise en service intermittent S3 (compatible avec le NPSHR)

(3) z = Immersion minima per motore senza mantello in funzione continuo S1 compatibilmente con l'NPSHR
y = Immersione minima con motore senza mantello in funzione intermittente S3 compatibilmente con l'NPSHR

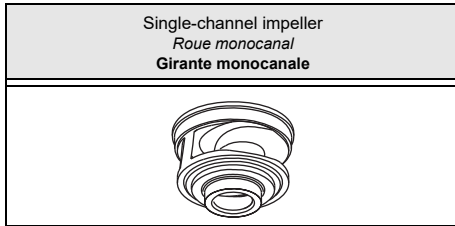

Type Type Tipo	KCM250R...+...42N3	
Thermal probes <i>Sondes thermiques</i> Sonda termiche	Yes <i>Oui</i> Sì	
Conductivity probe <i>Sonde de conductivité</i> Sonda di conduttività	Yes <i>Oui</i> Sì	

Version cable (1) <i>Version câble (1)</i> Cavo Versione (1)		
Electric pump type <i>Elettropompe type</i> Elettropompa tipo	Power supply <i>Alimentation</i> Alimentazione	Auxiliary <i>Auxiliaire</i> Ausiliario
KCM250RM+082042N3	2x(4x25)x10	1x(4x1,5)x10

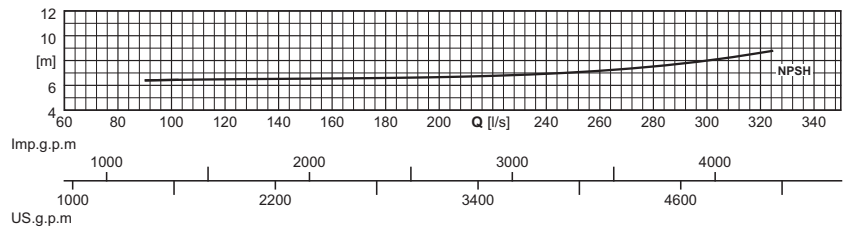
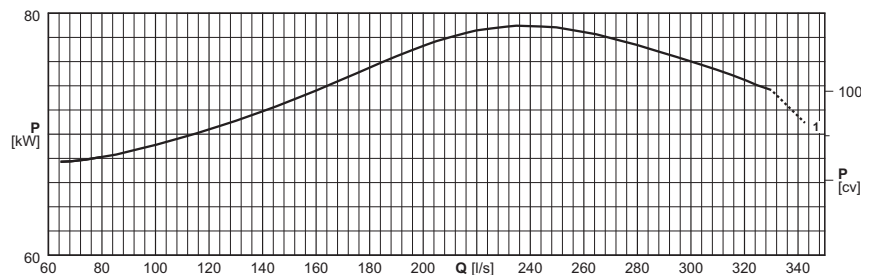
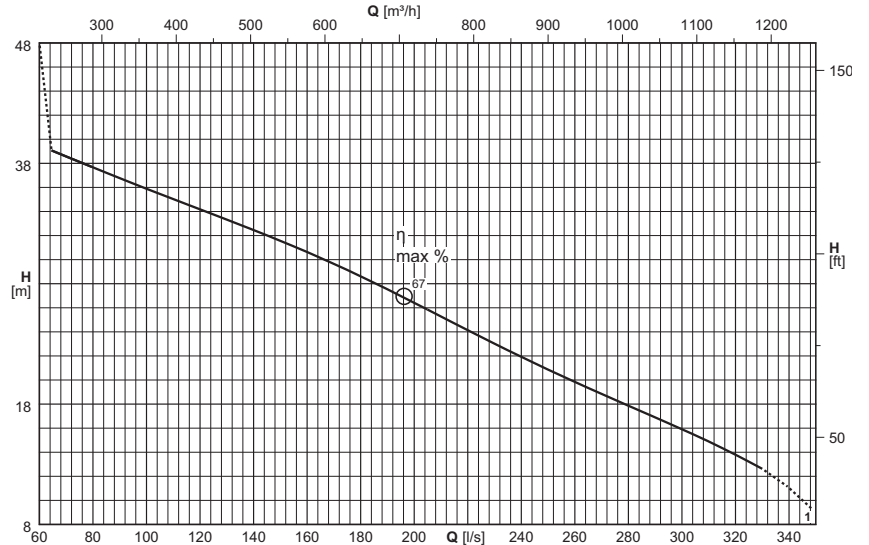

(1) = n°. of cables x (n°. of wires each cable x size [mm²]) x cable length [m] - Câble NSSHÖU-J

Cable length exceeding 10 m on request

(1) = n°. câbles x (n°. conducteurs câble x section [mm²]) x longueur câble [m] - Câble NSSHÖU-J

Sur demande longueur de câble supérieure à 10 m

(1) = n°. cavi x (n°. conduttori per cavo x sezione [mm²]) x lunghezza cavo [m] - Cavo NSSHÖU-J

Lunghezza cavo superiore a 10 m - su richiesta

Electric pump type <i>Elettropompe type</i> Elettropompa tipo	Curve <i>Courbe</i> Curva	Motor power <i>Puiss. moteur</i> Potenza motore	Capacity <i>Debit</i> Portata															
			[l/s]	0	70	80	90	100	125	150	175	200	225	250	275	300	325	348
		P ₂	[m ³ /h]	0	252	288	324	360	450	540	630	720	810	900	990	1080	1170	1252,8
	(N°)	[kW]	Head <i>Hauteur</i> Prevalenza															
KCM250RM+082042N3	1	82	[m]	45	38,6	37,7	36,8	35,9	33,8	31,6	29,1	26,4	23,6	20,9	18,4	15,9	13,1	9,4
NPSH _R			[m]		6,3	6,4	6,4	6,4	6,5	6,5	6,6	6,7	6,8	7	7,4	8	8,8	9,7

P₂ = Power rated by the motor

Performance tolerance as per:
UNI/ISO 9906 Grade 3B

(2) For models in the explosion-proof version KCM250R(X)

For motor performances specification see page "motor features"

For the accessories specification see page "Accessories"

P₂ = Puissance restituée par le moteur

Tolérances sur les performances selon normes:
UNI/ISO 9906 Niveau 3B

(2) Pour les modèles version antidéflagrante KCM250R(X)

Pour caractéristiques techniques moteurs voir page "Caractéristiques des moteurs"

Pour les accessoires voir page "Accessories"

P₂ = Potenza resa dal motore

Tolleranze sulle prestazioni secondo norme:
UNI/ISO 9906 Grado 3B

(2) Versione antidéflagrante vedere KCM250R(X)

Per caratteristiche motori vedere pagina "caratteristiche motori"

Per accessori vedere pagina accessori

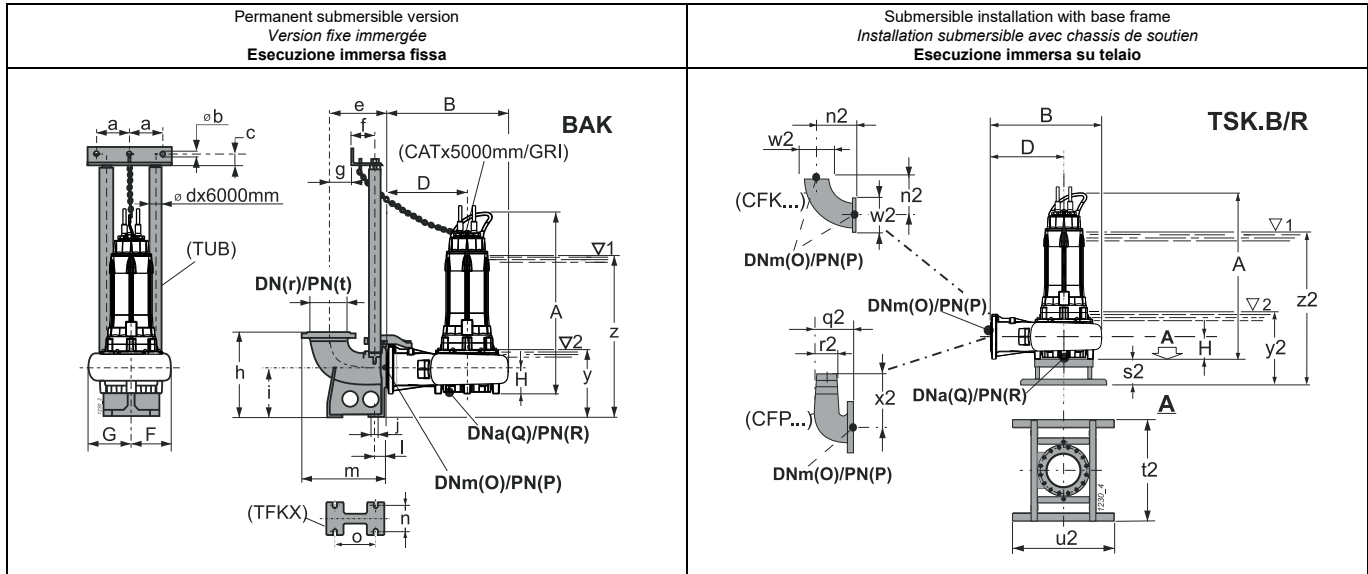

For fixed installation in a dry chamber - vertical (R)
Pour installation fixe en fosse sèche - verticale (R)
Esecuzione per camera asciutta - verticale (R)

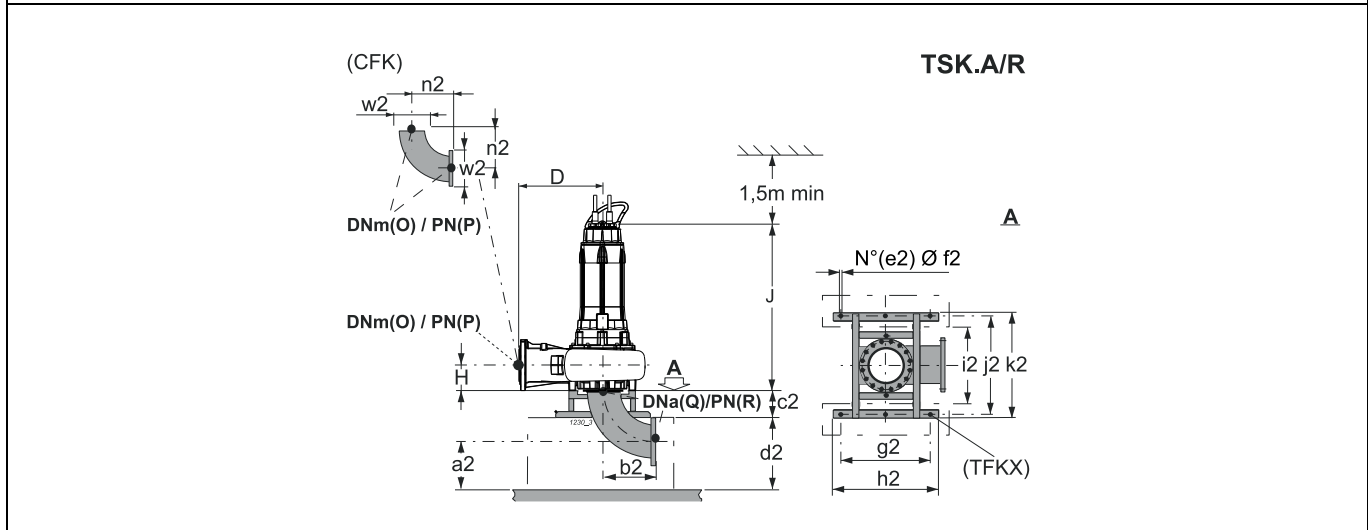

Type Type Tipo	Free passage Passage libre Passaggio Libero	Weight Poids Peso	[mm]													Accessories Accessoires Accessori				
			A	B	D	F	G	H	J	O	P	Q	R	BAK.	TSK.A/R	TSK.B/R				
KCM250RM+082042N3	Ø 163	967,7	1709	935	570	330	405	220	-	250	10	250	10	300/250 3"	-	350				
KCM250RM+082042N3/R	Ø 163	1006	1709	935	570	330	405	220	1475	250	10	250	10	300/250 3"	250	-				
BAK.			a	b	c	d	e	f	g	h	i	j	l	m	n	o	r	t	y	z
BAK300/250 3"			157,5	12,5	35	3"	450	117	245	700	400	24	85	673	310	425	300	10	610	1463
TSK.A/R			a2	b2	c2	d2	e2	f2	g2	h2	i2	j2	k2	n2	w2					
TSK250A/R			295	385	280	400	6	22	850	1000	740	935	1000	385	395					
TSK.B/R			n2	q2	r2	s2	t2	u2	w2	x2	y2	z2								
TSK350B/R			385	525	250	280	1000	1000	395	575	710	1563								

(3) z = Minimum submergence depth for motor without casing with continuous duty S1 (NPSHR permitting)

(3) z = Immersion minimum pour moteur sans chemise en service continu S1 (compatible avec le NPSHR)

(3) z = Immersion minima per motore senza mantello in funzione continuo S1 compatibile con l'NPSHR

y = Minimum submergence depth for motor without casing with intermittent duty S3 (NPSHR permitting)

y = Immersion minimum pour moteur sans chemise en service intermittent S3 (compatible avec le NPSHR)

y = Immersion minima con motore senza mantello in funzione intermittente S3 compatibilmente con l'NPSHR

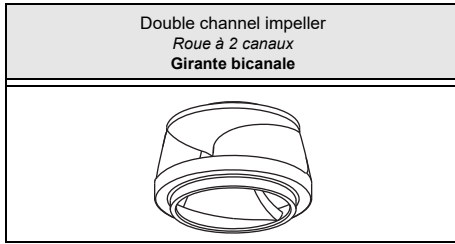

Type Type Tipo	KCD300Z...+...82N1	
Thermal probes Sondes termiques Sonde termiche	Yes Oui SI	
Conductivity probe Sonde de conductivité Sonda di conduttività	Yes Oui SI	

Version cable (1)
Version câble (1)
Cavo Versione (1)

Electric pump type Electropompe type Elettropompa tipo	Power supply Alimentation Alimentazione	Auxiliary Auxiliaire Ausiliario
KCD300ZE+017082N1/R	2x(4x6)x10	1x(5x1,5)x10
KCD300ZD+017082N1	2x(4x6)x10	1x(5x1,5)x10
KCD300ZB+021082N1/R	2x(4x6)x10	1x(5x1,5)x10
KCD300ZA+021082N1	2x(4x6)x10	1x(5x1,5)x10

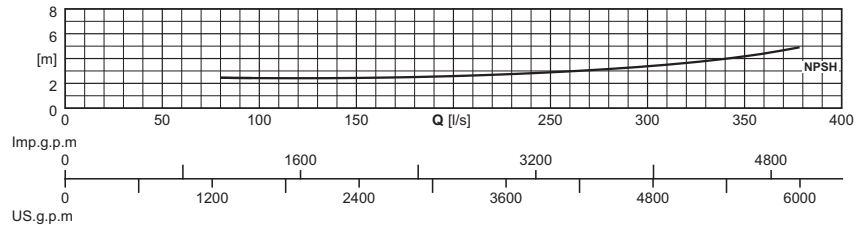
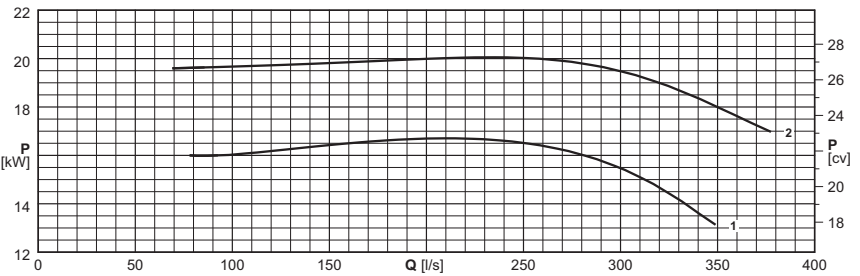
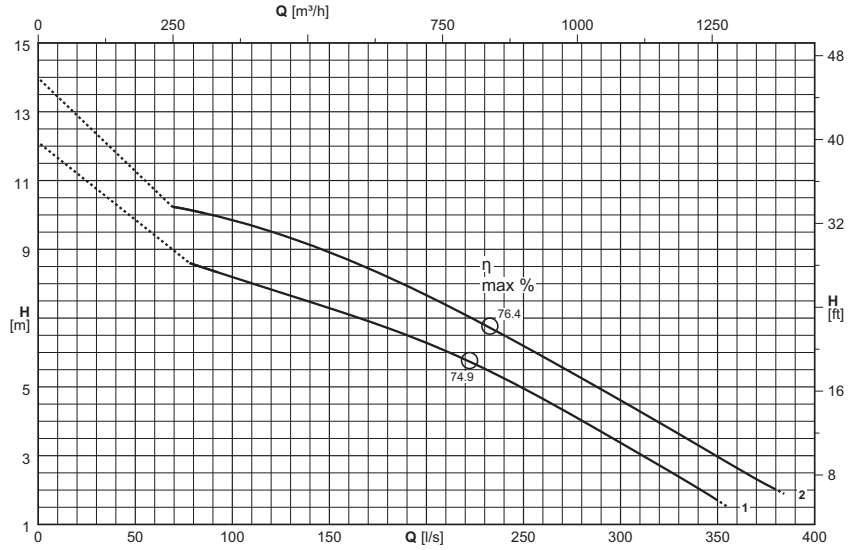

(1) = n°. of cables x (n°. of wires each cable x size [mm²]) x cable length [m] - Câble H07RN-F (OZOFLEX Plus)
Cable length exceeding 10 m on request

(1) = n°. câbles x (n°. conducteurs câble x section [mm²]) x longueur câble [m] - Câble H07RN-F (OZOFLEX Plus)
Sur demande longueur de câble supérieure à 10 m

(1) = n°. cavi x (n°. conduttori per cavo x sezione [mm²]) x lunghezza cavo [m] - Cavo H07RN-F (OZOFLEX Plus)
Lunghezza cavo superiore a 10 m - su richiesta

Electric pump type Electropompe type Elettropompa tipo	Curve Courbe Curva	Motor power Puiss. moteur Potenza motore	Capacity Débit Portata																	
			[l/s]	0	80	100	125	150	175	200	225	250	275	300	325	350	375	384		
			P ₂	[m³/h]	0	288	360	450	540	630	720	810	900	990	1080	1170	1260	1350	1382,4	
			(N°)	[kW]	Head Hauteur Prevalenza															
			[m]	[m]	11,1	8,6	8,2	7,7	7,3	6,8	6,3	5,7	5	4,2	3,4	2,6	1,7			
●KCD300ZE+017082N1/R	1	17	[m]	[m]	11,1	8,6	8,2	7,7	7,3	6,8	6,3	5,7	5	4,2	3,4	2,6	1,7			
○KCD300ZD+017082N1	1	17	[m]	[m]	11,1	8,6	8,2	7,7	7,3	6,8	6,3	5,7	5	4,2	3,4	2,6	1,7			
●KCD300ZB+021082N1/R	2	21	[m]	[m]	13	10,1	9,8	9,4	8,9	8,3	7,7	6,9	6,2	5,4	4,6	3,8	3	2,2	1,9	
○KCD300ZA+021082N1	2	21	[m]	[m]	13	10,1	9,8	9,4	8,9	8,3	7,7	6,9	6,2	5,4	4,6	3,8	3	2,2	1,9	
NPSH _R			[m]	[m]		2,5	2,4	2,4	2,4	2,5	2,6	2,7	2,9	3,1	3,4	3,7	4,2	4,8	5,1	

● Fixed installation in a dry chamber (R)
○ Submersible version
P₂ = Power rated by the motor
Performance tolerance as per:
UNI/ISO 9906 Grade 3B

(2) For models in the explosion-proof version KCD300Z(X)
For motor performances specification see page "motor features"

For the accessories specification see page "Accessories"
The impellers will be trimmed to meet the duty point

● Installation fixe en fosse sèche (R)
○ Version immergée
P₂ = Puissance restituée par le moteur
Tolérances sur les performances selon normes:
UNI/ISO 9906 Niveau 3B

(2) Pour les modèles version antidéflagrante KCD300Z(X)
Pour caractéristiques techniques moteurs voir page "Caractéristiques des moteurs"

Pour les accessoires voir page "Accessories"
Le point de fonctionnement désiré peut être obtenu par rognage de roue

● Esecuzione per camera asciutta (R)
○ Esecuzione Immersa
P₂ = Potenza resa dal motore
Tolleranze sulle prestazioni secondo norme:
UNI/ISO 9906 Grado 3B

(2) Versione antidéflagrante vedere KCD300Z(X)
Per caratteristiche motori vedere pagina "caratteristiche motori"

Per accessori vedere pagina accessori
Le giranti vengono tornite in modo da ottenere il punto di lavoro richiesto

(N)

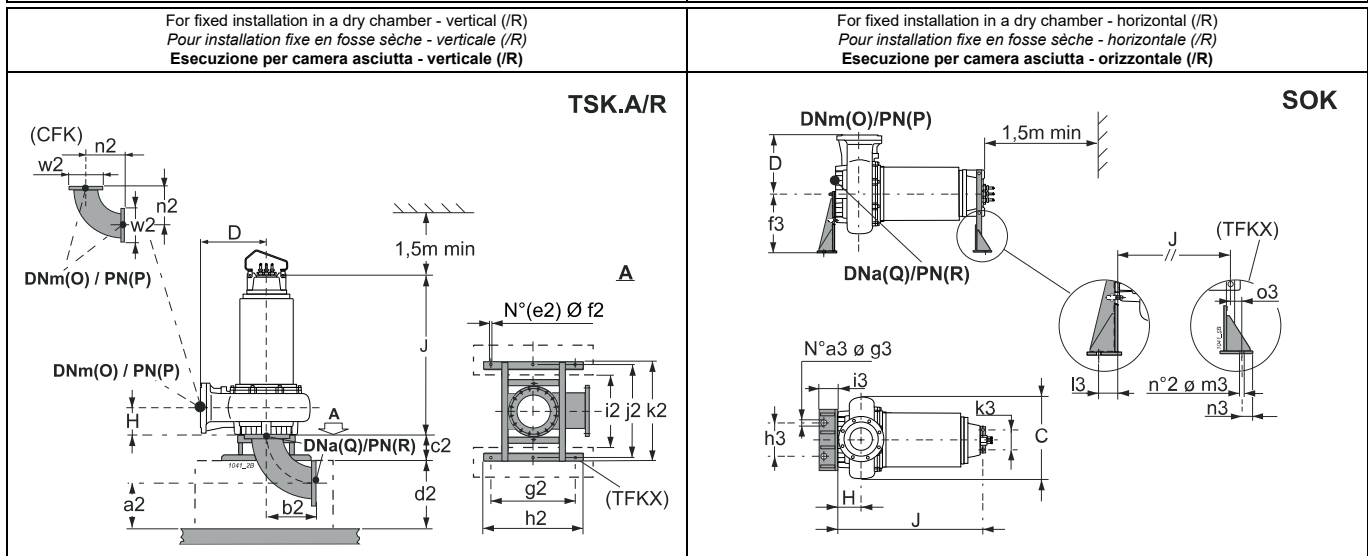
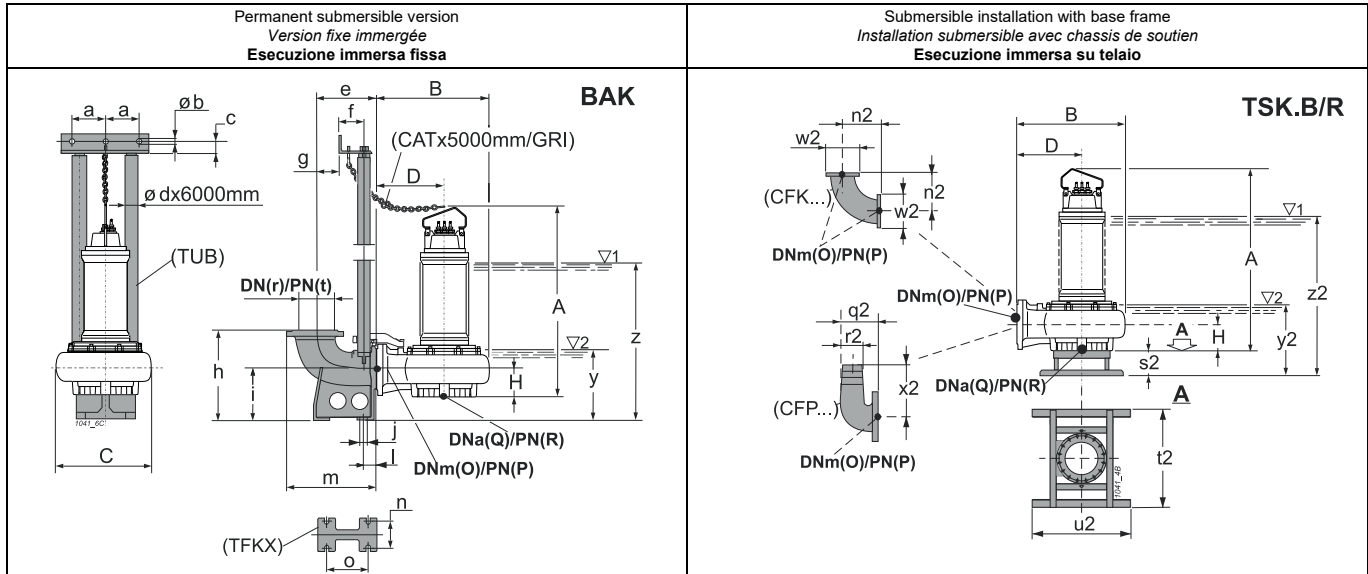

Type Type Tipo	Free passage Passage libre Passaggio Libero	Weight Poids Peso	[mm]											Accessories Accessoires Accessori					
			A	B	C	D	H	J	O	P	Q	R	BAK.	SOK.	TSK.A/R	TSK.B/R			
●KCD300ZE+017082N1/R	Ø 143	761	1599,5	1030	820	620	230	1322	300	10	300	10	350/300 3"	350-200	300	-			
○KCD300ZD+017082N1	Ø 143	656	1599,5	1030	820	620	230	-	300	10	300	10	350/300 3"	-	-	350			
●KCD300ZB+021082N1/R	Ø 143	691	1599,5	1030	820	620	230	1322	300	10	300	10	350/300 3"	350-200	300	-			
○KCD300ZA+021082N1	Ø 143	676	1599,5	1030	820	620	230	-	300	10	300	10	350/300 3"	-	-	350			
BAK.	a	b	c	d	e	f	g	h	i	j	l	m	n	o	r	t	y	z	
BAK350/300 3"	157,5	12,5	35	3"	500	117	295	820	500	24	90	755	360	475	350	10	665	1410	
SOK.	a3	f3	g3	h3	i3	k3	l3	m3	n3	o3									
SOK350-200	3	530	22	500	160	270	100	22	40	85									
TSK.A/R	a2	b2	c2	d2	e2	f2	g2	h2	i2	j2	k2	n2	w2						
TSK300A/R	320	465	280	500	6	22	850	1000	740	935	1000	465	445						
TSK.B/R	n2	s2	t2	u2	w2	y2	z2												
TSK350B/R	465	280	1000	1000	445	675	1420												

(3) z = Minimum submergence depth for motor without casing with continuous duty S1 (NPSHR permitting)

y = Minimum submergence depth for motor without casing with intermittent duty S3 (NPSHR permitting)

(3) z = Immersion minimum pour moteur sans chemise en service continu S1 (compatible avec le NPSHR)

y = Immersion minimum pour moteur sans chemise en service intermittent S3 (compatible avec le NPSHR)

(3) z = Immersion minima per motore senza mantello in funzione continuo S1 compatibilmente con l'NPSHR

y = Immersion minima con motore senza mantello in funzione intermittente S3 compatibilmente con l'NPSHR

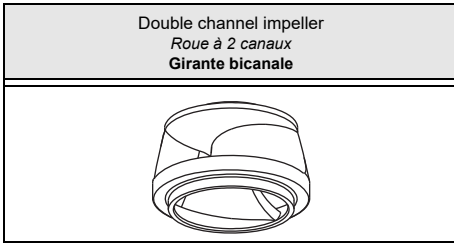

Type Type Tipo	KCD300R...62N3	
Thermal probes Sondes thermiques Sonda termiche	Yes Oui Sì	
Conductivity probe Sonde de conductivité Sonda di conduttività	Yes Oui Sì	

Version cable (1)
Version câble (1)
Cavo Versione (1)

Electric pump type Electropompe type Elettropompa tipo	Power supply Alimentation Alimentazione	Auxiliary Auxiliaire Ausiliario
KCD300RN+025062N3/R	2x(4x10)x10	1x(4x1,5)x10
KCD300RM+025062N3	2x(4x10)x10	1x(4x1,5)x10
KCD300RH+034062N3/R	2x(4x10)x10	1x(4x1,5)x10
KCD300RG+034062N3	2x(4x10)x10	1x(4x1,5)x10
KCD300RE+042062N3/R	2x(4x16)x10	1x(4x1,5)x10
KCD300RD+042062N3	2x(4x16)x10	1x(4x1,5)x10
KCD300RB+051062N3/R	2x(4x25)x10	1x(4x1,5)x10
KCD300RA+051062N3	2x(4x25)x10	1x(4x1,5)x10

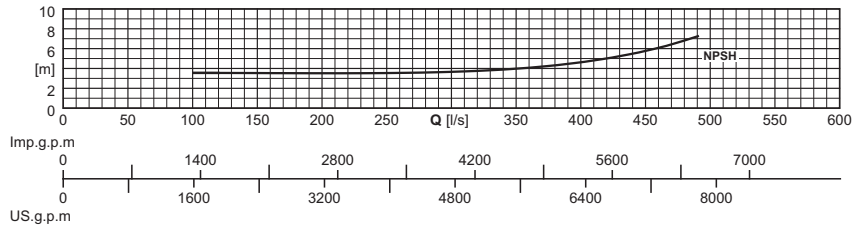
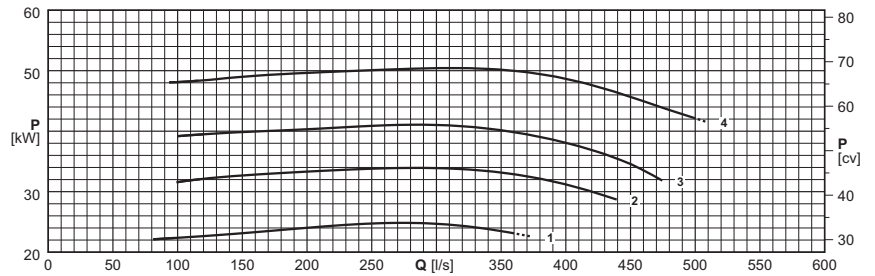
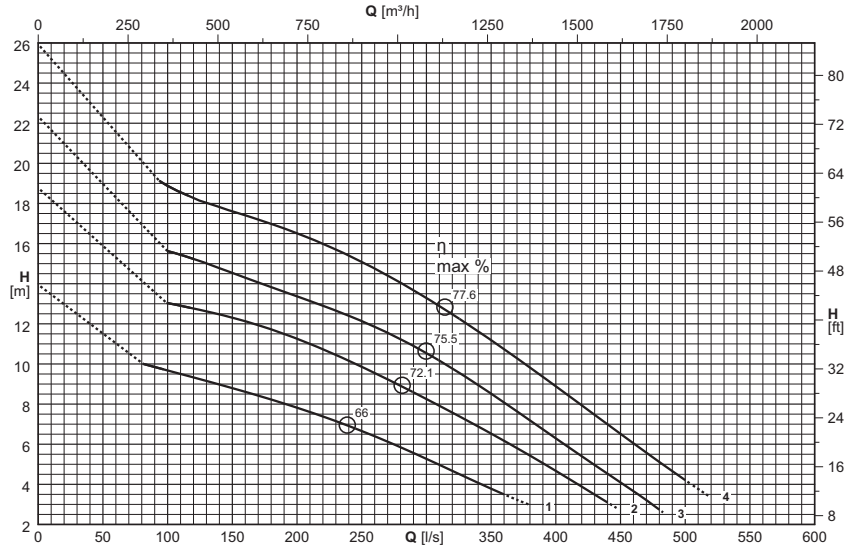

(1) = n°. of cables x (n°. of wires each cable x size [mm²]) x cable length [m] - Câble NSSHOU-J

Cable length exceeding 10 m on request

(1) = n°. câbles x (n°. conducteurs câble x section [mm²]) x longueur câble [m] - Câble NSSHOU-J

Sur demande longueur de câble supérieure à 10 m

(1) = n°. cavi x (n°. conduttori per cavo x sezione [mm²]) x lunghezza cavo [m] - Cavo NSSHOU-J

Lunghezza cavo superiore a 10 m - su richiesta

Electric pump type Electropompe type Elettropompa tipo	Curve Courbe Curva	Motor power Puiss. moteur Potenza motore	Capacity Débit Portata																	
			[l/s]	0	90	100	125	150	175	200	250	300	350	400	450	500	517			
	(N°)	[kW]	P ₂	[m ³ /h]	0	324	360	450	540	630	720	900	1080	1260	1440	1620	1800	1861,2		
					Head Hauteur Prevalenza															
				[m]	12	9,8	9,7	9,2	8,8	8,3	7,8	6,7	5,3	3,8						
● KCD300RN+025062N3/R	1	25		[m]	12	9,8	9,7	9,2	8,8	8,3	7,8	6,7	5,3	3,8						
○ KCD300RM+025062N3(R)	1	25		[m]	12	9,8	9,7	9,2	8,8	8,3	7,8	6,7	5,3	3,8						
● KCD300RH+034062N3/R	2	34		[m]	16,8		13	12,7	12,3	11,8	11,2	9,9	8,3	6,5	4,7					
○ KCD300RG+034062N3(R)	2	34		[m]	16,8		13	12,7	12,3	11,8	11,2	9,9	8,3	6,5	4,7					
● KCD300RE+042062N3/R	3	42		[m]	20,3		15,6	15,1	14,5	13,9	13,4	12,1	10,5	8,5	6,3	4,1				
○ KCD300RD+042062N3(R)	3	42		[m]	20,3		15,6	15,1	14,5	13,9	13,4	12,1	10,5	8,5	6,3	4,1				
● KCD300RB+051062N3/R	4	51		[m]	23,9		18,9	18,2	17,6	17,1	16,5	15,1	13,3	11,2	8,9	6,5	4,2	3,5		
○ KCD300RA+051062N3(R)	4	51		[m]	23,9		18,9	18,2	17,6	17,1	16,5	15,1	13,3	11,2	8,9	6,5	4,2	3,5		
NPSH _R				[m]			3,5	3,5	3,5	3,5	3,5	3,6	3,7	4	4,6	5,7	7,8	8,6		

● Fixed installation in a dry chamber (I/R)

○ Submersible version

P₂ = Power rated by the motor

Performance tolerance as per:
UNI/ISO 9906 Grade 3B

(2) For models in the explosion-proof version KCD300R(X)

For motor performances specification see page "motor features"

For the accessories specification see page "Accessories"

The impellers will be trimmed to meet the duty point

● Installation fixe en fosse sèche (I/R)

○ Version immergée

P₂ = Puissance restituée par le moteur

Tolérances sur les performances selon normes:
UNI/ISO 9906 Niveau 3B

(2) Pour les modèles version antidéflagrante KCD300R(X)

Pour caractéristiques techniques moteurs voir page "Caractéristiques des moteurs"

Pour les accessoires voir page "Accessories"

Le point de fonctionnement désiré peut être obtenu par rognage de roue

● Esecuzione per camera asciutta (I/R)

○ Esecuzione Immersa

P₂ = Potenza resa dal motore

Tolleranze sulle prestazioni secondo norme:
UNI/ISO 9906 Grado 3B

(2) Versione antidéflagrante vedere KCD300R(X)

Per caratteristiche motori vedere pagina "caratteristiche motori"

Per accessori vedere pagina accessori

Le giranti vengono tornite in modo da ottenere il punto di lavoro richiesto

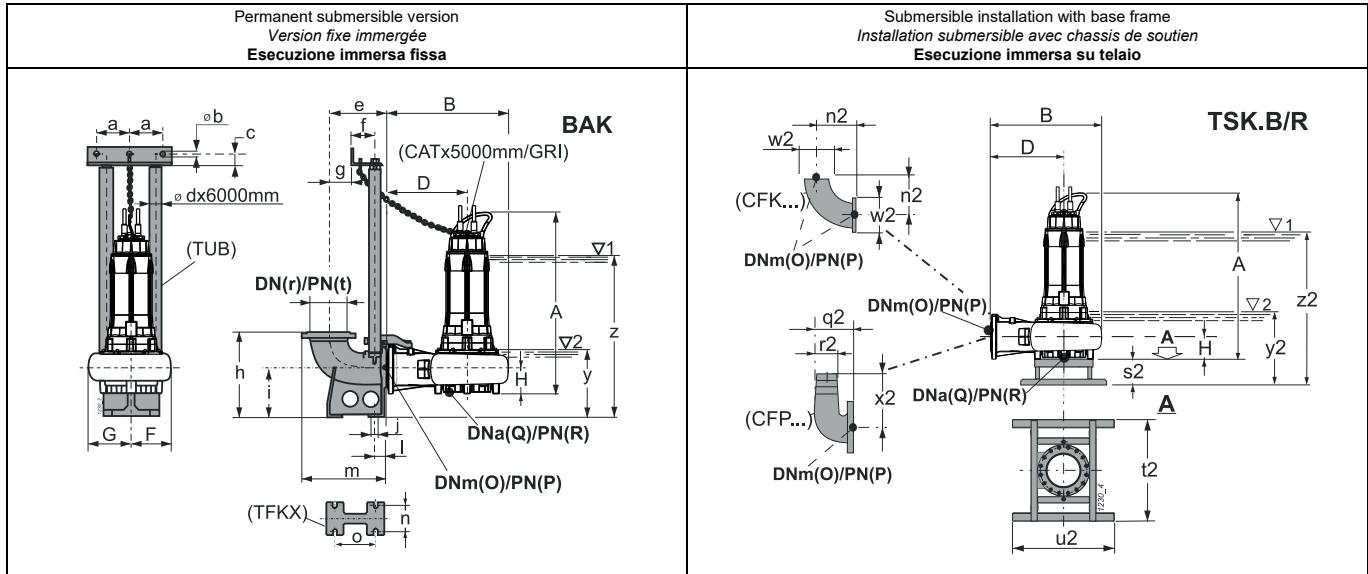

For fixed installation in a dry chamber - vertical (R)
Pour installation fixe en fosse sèche - verticale (R)
Esecuzione per camera asciutta - verticale (R)

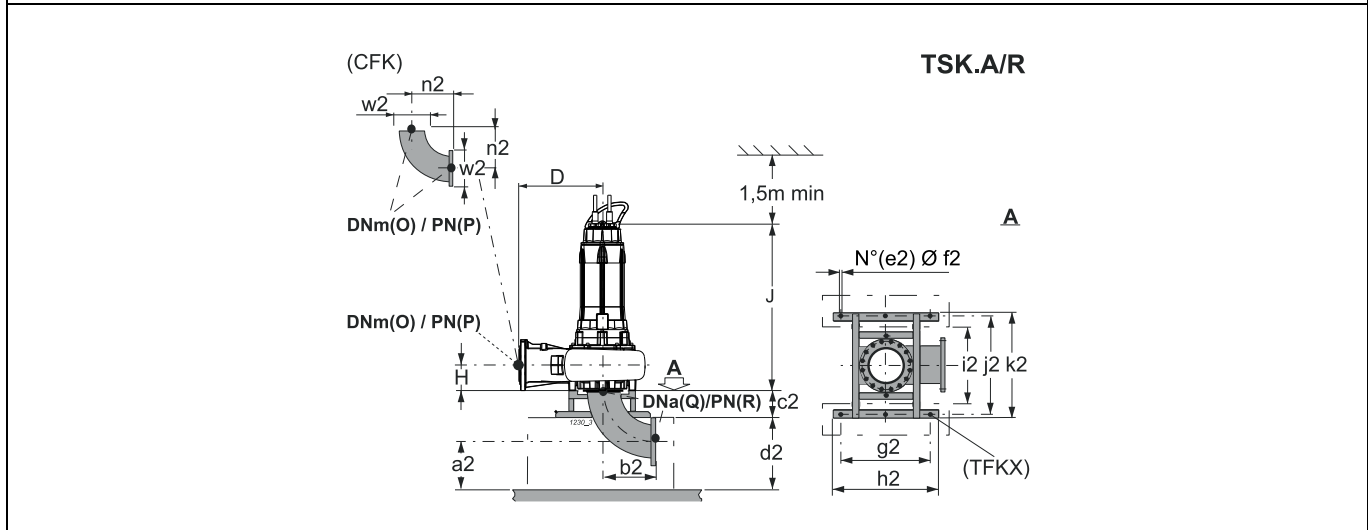

Type Type Tipo	Free passage Passage libre Passaggio Libero	Weight Poids Peso	[mm]													Accessories Accessori		
			A	B	D	F	G	H	J	O	P	Q	R	BAK	TSK.A/R	TSK.B/R		
●KCD300RN+025062N3/R	Ø 143	835,1	-	-	620	-	-	230	1375	300	10	300	10	-	300	-		
○KCD300RM+025062N3	Ø 143	796,8	1609	1030	620	340	480	230	-	300	10	300	10	350/300 3"	-	350		
●KCD300RM+025062N3/R	Ø 143	835,1	1609	1030	620	340	480	230	-	300	10	300	10	350/300 3"	-	350		
●KCD300RH+034062N3/R	Ø 143	840,4	-	-	620	-	-	230	1375	300	10	300	10	-	300	-		
○KCD300RG+034062N3	Ø 143	802,1	1609	1030	620	340	480	230	-	300	10	300	10	350/300 3"	-	350		
●KCD300RG+034062N3/R	Ø 143	840,4	1609	1030	620	340	480	230	-	300	10	300	10	350/300 3"	-	350		
●KCD300RE+042062N3/R	Ø 143	916,3	-	-	620	-	-	230	1429	300	10	300	10	-	300	-		
○KCD300RD+042062N3	Ø 143	878	1663	1030	620	340	480	230	-	300	10	300	10	350/300 3"	-	350		
●KCD300RD+042062N3/R	Ø 143	916,3	1663	1030	620	340	480	230	-	300	10	300	10	350/300 3"	-	350		
●KCD300RB+051062N3/R	Ø 143	1018,55	-	-	620	-	-	230	1462	300	10	300	10	-	300	-		
○KCD300RA+051062N3	Ø 143	980,25	1696	1030	620	340	480	230	-	300	10	300	10	350/300 3"	-	350		
●KCD300RA+051062N3/R	Ø 143	1018,6	1696	1030	620	340	480	230	-	300	10	300	10	350/300 3"	-	350		
BAK.	a	b	c	d	e	f	g	h	i	j	l	m	n	o	r	t	y	z
BAK350/300 3"	157,5	12,5	35	3"	500	117	295	820	500	24	90	755	360	475	350	10	687	1540
TSK.A/R	a2	b2	c2	d2	e2	f2	g2	h2	i2	j2	k2	n2	w2					
TSK300A/R	320	465	280	500	6	22	850	1000	740	935	1000	465	445					
TSK.B/R	n2	s2	t2	u2	w2	y2	z2											
TSK350B/R	465	280	1000	1000	445	697	1550											

(3) z = Minimum submergence depth for motor without casing with continuous duty S1 (NPSHR permitting)
y = Minimum submergence depth for motor without casing with intermittent duty S3 (NPSHR permitting)

(3) z = Immersion minimum pour moteur sans chemise en service continu S1 (compatible avec le NPSHR)
y = Immersion minimum pour moteur sans chemise en service intermittent S3 (compatible avec le NPSHR)

(3) z = Immersion minima per motore senza mantello in funzione continuo S1 compatibilmente con l'NPSHR
y = Immersion minima con motore senza mantello in funzione intermittente S3 compatibilmente con l'NPSHR

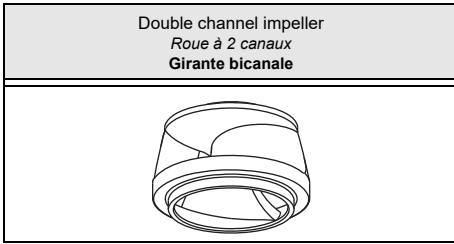

Type Type Tipo	KCD300R...42N3	
Thermal probes Sondes thermiques Sonda termiche	Yes Oui SI	
Conductivity probe Sonde de conductivité Sonda di conduttività	Yes Oui SI	

Version cable (1)
Version câble (1)
Cavo Versione (1)

Electric pump type Electropompe type Elettropompa tipo	Power supply Alimentation Alimentazione	Auxiliary Auxiliaire Ausiliario
KCD300RQ+082042N3/R	2x(4x25)x10	1x(4x1,5)x10
KCD300RN+082042N3	2x(4x25)x10	1x(4x1,5)x10

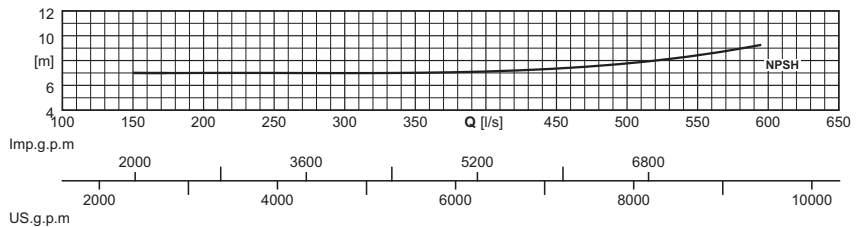
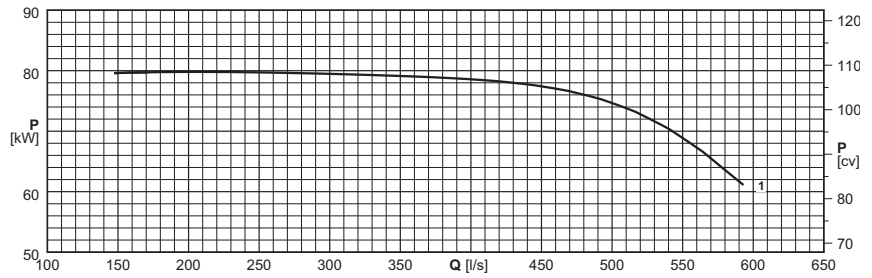
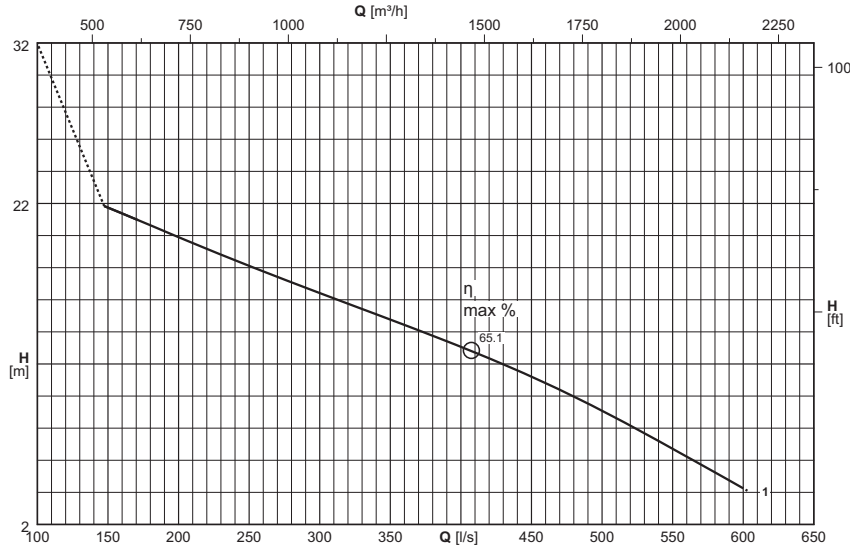

(1) = n°. of cables x (n°. of wires each cable x size [mm²]) x cable length [m] - Cable NSSHÖU-J

Cable length exceeding 10 m on request

(1) = n°. câbles x (n°. conducteurs câble x section [mm²]) x longueur câble [m] - Câble NSSHÖU-J

Sur demande longueur de câble supérieure à 10 m

(1) = n°. cavi x (n°. conduttori per cavo x sezione [mm²]) x lunghezza cavo [m] - Cavo NSSHÖU-J

Lunghezza cavo superiore a 10 m - su richiesta

Electric pump type Electropompe type Elettropompa tipo	Curve Courbe Curva	Motor power Puiss. moteur Potenza motore	Capacity Débit Portata													
			[l/s]	0	150	175	200	250	300	350	400	450	500	550	600	603
		P ₂	[m³/h]	0	540	630	720	900	1080	1260	1440	1620	1800	1980	2160	2170,8
	(N°)	[kW]	Head Hauteur Prevalenza													
●KCD300RQ+082042N3/R	1	82	[m]	30	23,2	22,1	21,1	19	17	15,1	13,1	11,1	9	6,7	4,3	4,1
○KCD300RN+082042N3(R)	1	82	[m]	30	23,2	22,1	21,1	19	17	15,1	13,1	11,1	9	6,7	4,3	4,1
NPSH _R			[m]		7	7	7	7	7	7	7,1	7,3	7,8	8,4	9,4	9,5

● Fixed installation in a dry chamber (/R)

○ Submersible version

P₂ = Power rated by the motor

Performance tolerance as per:
UNI/ISO 9906 Grade 3B

(2) For models in the explosion-proof version KCD300R(X)

For motor performances specification see page "motor features"

For the accessories specification see page "Accessories"

The impellers will be trimmed to meet the duty point

● Installation fixe en fosse sèche (/R)

○ Version immergée

P₂ = Puissance restituée par le moteur

Tolérances sur les performances selon normes:
UNI/ISO 9906 Niveau 3B

(2) Pour les modèles version antidéflagrante KCD300R(X)

Pour caractéristiques techniques moteurs voir page "Caractéristiques des moteurs"

Pour les accessoires voir page "Accessories"

Le point de fonctionnement désiré peut être obtenu par rognage de roue

● Esecuzione per camera asciutta (/R)

○ Esecuzione Immersa

P₂ = Potenza resa dal motore

Tolleranze sulle prestazioni secondo norme:
UNI/ISO 9906 Grado 3B

(2) Versione antideflagrante vedere KCD300R(X)

Per caratteristiche motori vedere pagina "caratteristiche motori"

Per accessori vedere pagina accessori

Le giranti vengono tornite in modo da ottenere il punto di lavoro richiesto

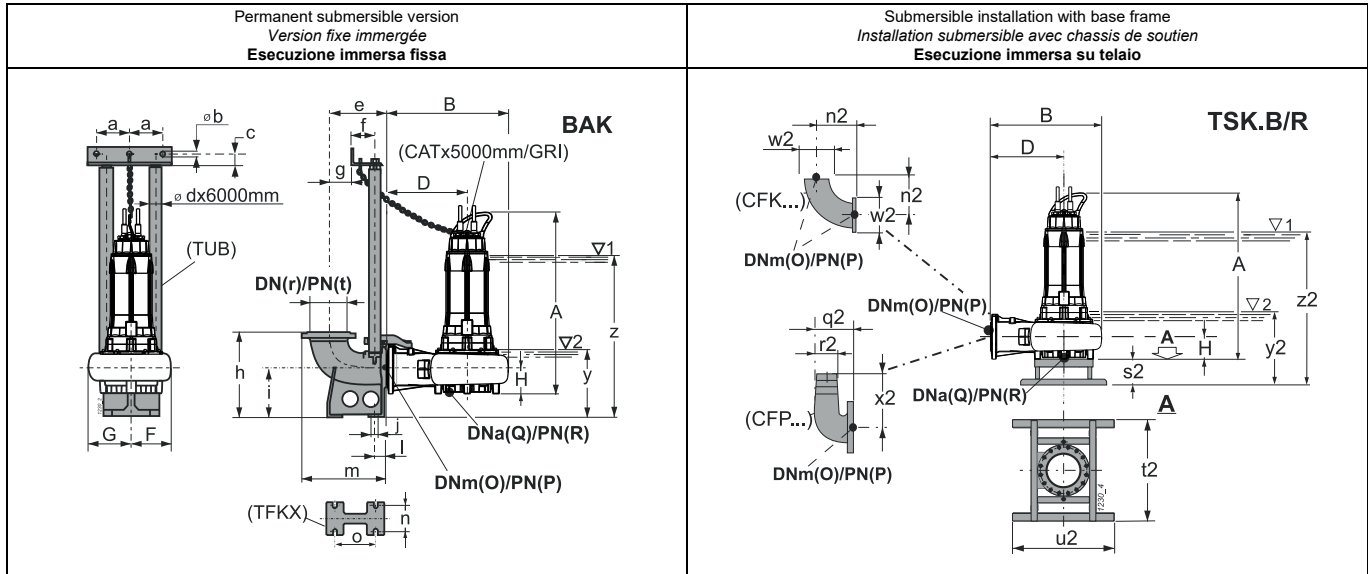

For fixed installation in a dry chamber - vertical (R)
Pour installation fixe en fosse sèche - verticale (R)
Esecuzione per camera asciutta - verticale (R)

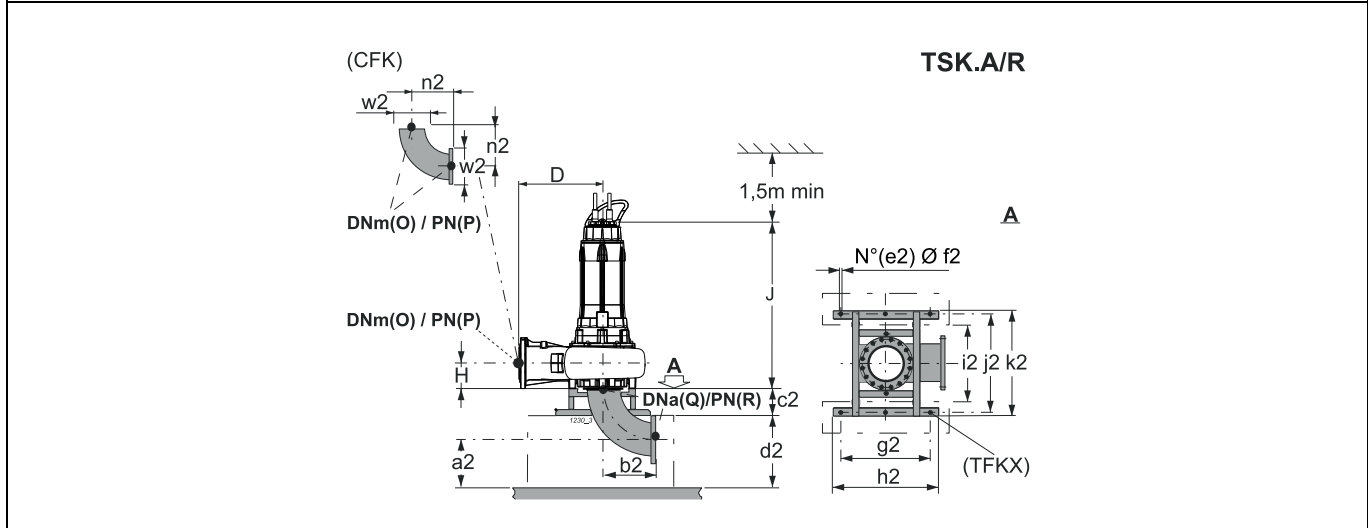

Type Type Tipo	Free passage Passage libre Passaggio Libero	Weight Poids Peso	[mm]													Accessories Accessoires Accessori				
			A	B	D	F	G	H	J	O	P	Q	R	BAK	TSK.A/R	TSK.B/R				
●KCD300RQ+082042N3/R	Ø 143	1014,2	-	-	620	-	-	230	1462	300	10	300	10	-	300	-				
○KCD300RN+082042N3	Ø 143	975,9	1696	1030	620	340	480	230	-	300	10	300	10	350/300 3"	-	350				
●KCD300RN+082042N3/R	Ø 143	1014,2	1696	1030	620	340	480	230	-	300	10	300	10	350/300 3"	-	350				
BAK.			a	b	c	d	e	f	g	h	i	j	l	m	n	o	r	t	y	z
BAK350/300 3"			157,5	12,5	35	3"	500	117	295	820	500	24	90	755	360	475	350	10	687	1540
TSK.A/R			a2	b2	c2	d2	e2	f2	g2	h2	i2	j2	k2	n2	w2					
TSK300A/R			320	465	280	500	6	22	850	1000	740	935	1000	465	445					
TSK.B/R			n2	s2	t2	u2	w2	y2	z2											
TSK350B/R			465	280	1000	1000	445	697	1550											

(3) z = Minimum submergence depth for motor without casing with continuous duty S1 (NPSHR permitting)
y = Minimum submergence depth for motor without casing with intermittent duty S3 (NPSHR permitting)

(3) z = Immersion minimum pour moteur sans chemise en service continu S1 (compatible avec le NPSHR)
y = Immersion minimum pour moteur sans chemise en service intermittent S3 (compatible avec le NPSHR)

(3) z = Immersion minima per motore senza mantello in funzione continuo S1 compatibilmente con l'NPSHR
y = Immersione minima con motore senza mantello in funzione intermittente S3 compatibilmente con l'NPSHR

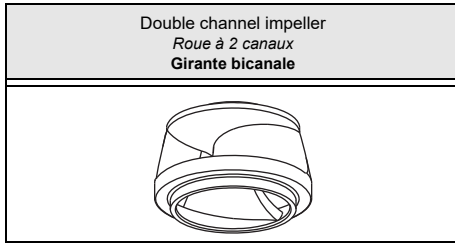

Type Type Tipo	KCD350R...82N1	
Thermal probes Sondes termiques Sonda termiche	Yes Oui SI	
Conductivity probe Sonde de conductivité Sonda di conduttività	Yes Oui SI	

Version cable (1) Version câble (1) Cavo Versione (1)		
Electric pump type Electropompe type Elettropompa tipo	Power supply Alimentation Alimentazione	Auxiliary Auxiliaire Ausiliario
KCD350RT+021082N1/R	2x(4x6)x10	1x(4x1,5)x10
KCD350RS+021082N1	2x(4x6)x10	1x(4x1,5)x10
KCD350RP+025082N1/R	2x(4x16)x10	1x(4x1,5)x10
KCD350RO+025082N1	2x(4x16)x10	1x(4x1,5)x10
KCD350RH+034082N1/R	2x(4x16)x10	1x(4x1,5)x10
KCD350RG+034082N1	2x(4x16)x10	1x(4x1,5)x10
KCD350RB+042082N1/R	2x(4x25)x10	1x(4x1,5)x10
KCD350RA+042082N1	2x(4x25)x10	1x(4x1,5)x10

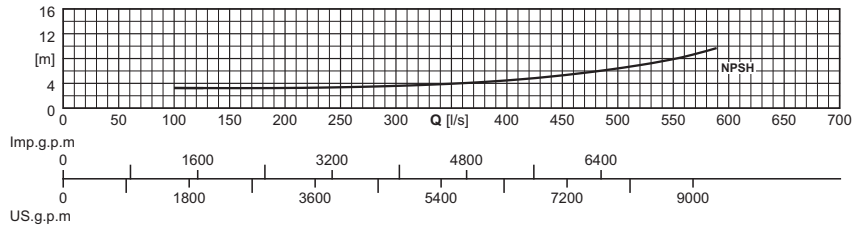
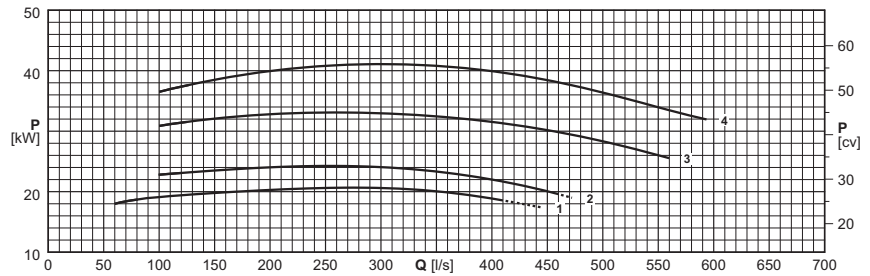
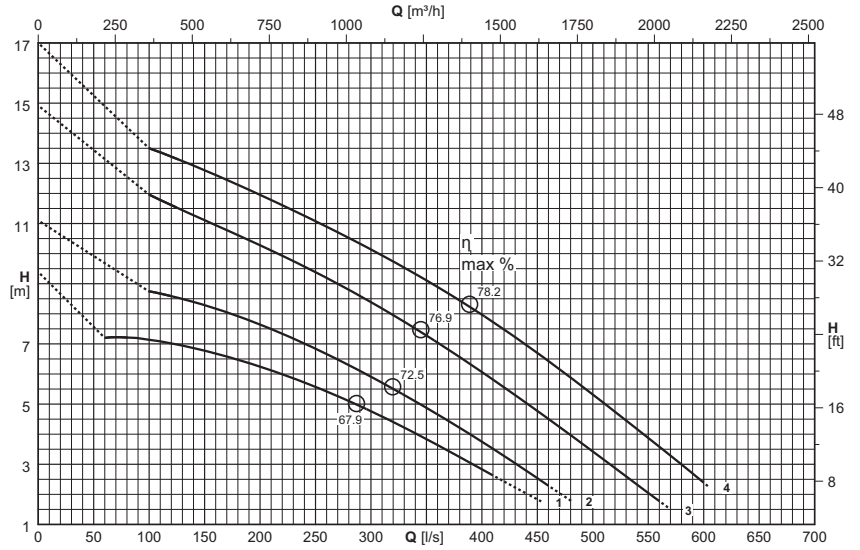

(1) = n°. of cables x (n°. of wires each cable x size [mm²]) x cable length [m] - Câble H07RN-F (OZOFLEX Plus)
Cable length exceeding 10 m on request

(1) = n°. câbles x (n°. conducteurs câble x section [mm²]) x longueur câble [m] - Câble H07RN-F (OZOFLEX Plus)
Sur demande longueur de câble supérieure à 10 m

(1) = n°. cavi x (n°. conduttori per cavo x sezione [mm²]) x lunghezza cavo [m] - Cavo H07RN-F (OZOFLEX Plus)
Lunghezza cavo superiore a 10 m - su richiesta

Electric pump type Electropompe type Elettropompa tipo	Curve Courbe Curva	Motor power Puiss. moteur Potenza motore	Capacity Débit Portata																		
			[l/s]	0	70	75	100	125	150	175	200	250	300	350	400	450	500	550	600	604	
		P ₂	[m ³ /h]	0	252	270	360	450	540	630	720	900	1080	1260	1440	1620	1800	1980	2160	2174,4	
	(N°)	[kW]	Head Hauteur Prevalenza																		
			[m]	8,4	7,2	7,2	7,1	7	6,8	6,5	6,2	5,6	4,8	3,8	2,8	1,8					
●KCD350RT+021082N1/R	1	21	[m]	8,4	7,2	7,2	7,1	7	6,8	6,5	6,2	5,6	4,8	3,8	2,8	1,8					
○KCD350RS+021082N1	1	21	[m]	8,4	7,2	7,2	7,1	7	6,8	6,5	6,2	5,6	4,8	3,8	2,8	1,8					
●KCD350RP+025082N1/R	2	25	[m]	10,1			8,7	8,5	8,3	8	7,6	6,8	5,9	4,9	3,8	2,5					
○KCD350RO+025082N1	2	25	[m]	10,1			8,7	8,5	8,3	8	7,6	6,8	5,9	4,9	3,8	2,5					
●KCD350RH+034082N1/R	3	34	[m]	13,9			12	11,5	11,1	10,7	10,3	9,4	8,4	7,3	6,1	4,8	3,4	2			
○KCD350RG+034082N1	3	34	[m]	13,9			12	11,5	11,1	10,7	10,3	9,4	8,4	7,3	6,1	4,8	3,4	2			
●KCD350RB+042082N1/R	4	42	[m]	16,1			13,5	13,1	12,8	12,4	12	11,1	10,1	9,1	8	6,7	5,3	3,9	2,4	2,3	
○KCD350RA+042082N1	4	42	[m]	16,1			13,5	13,1	12,8	12,4	12	11,1	10,1	9,1	8	6,7	5,3	3,9	2,4	2,3	
NPSH _R			[m]				3,3	3,2	3,2	3,2	3,3	3,4	3,6	3,9	4,5	5,3	6,4	7,9	10,5	10,8	

● Fixed installation in a dry chamber (I/R)
○ Submersible version

P₂ = Power rated by the motor
Performance tolerance as per:
UNI/ISO 9906 Grade 3B

(2) For models in the explosion-proof version KCD350R(X)
For motor performances specification see page "motor features"

For the accessories specification see page "Accessories"
The impellers will be trimmed to meet the duty point

● Installation fixe en fosse sèche (I/R)
○ Version immergée

P₂ = Puissance restituée par le moteur
Tolérances sur les performances selon normes:
UNI/ISO 9906 Niveau 3B

(2) Pour les modèles version antidéflagrante KCD350R(X)
Pour caractéristiques techniques moteurs voir page "Caractéristiques des moteurs"

Pour les accessoires voir page "Accessories"
Le point de fonctionnement désiré peut être obtenu par rognage de roue

● Esecuzione per camera asciutta (I/R)
○ Esecuzione Immersa

P₂ = Potenza resa dal motore
Tolleranze sulle prestazioni secondo norme:
UNI/ISO 9906 Grado 3B

(2) Versione antideflagrante vedere KCD350R(X)
Per caratteristiche motori vedere pagina "caratteristiche motori"

Per accessori vedere pagina accessori
Le giranti vengono tornite in modo da ottenere il punto di lavoro richiesto

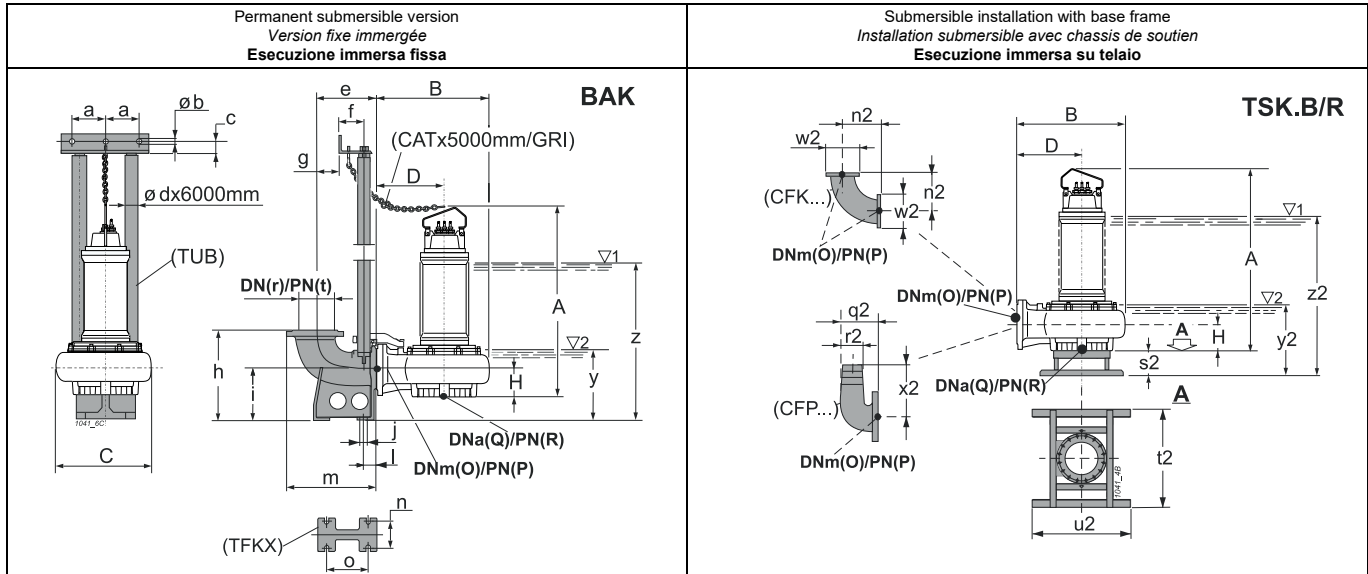

Permanent submersible version
Version fixe immergée
Esecuzione immersa fissa

Submersible installation with base frame
Installation submersible avec chassis de soutien
Esecuzione immersa su telaio

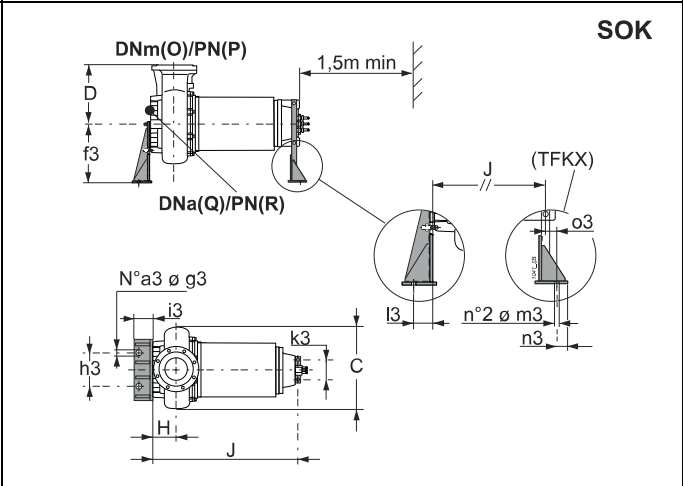
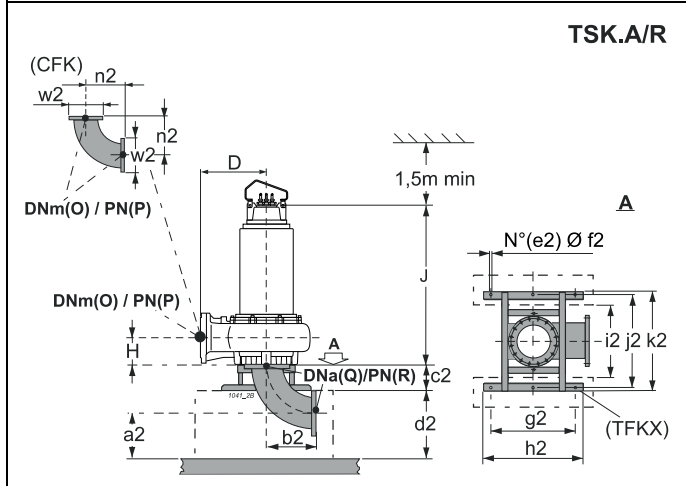

Type Type Tipo	Free passage Passage libre Passaggio Libero	Weight Poids Peso	[mm]												Accessories Accessoires Accessori			
			A	B	C	D	H	J	O	P	Q	R	BAK.	SOK.	TSK.A/R	TSK.B/R		

●KCD350RT+021082N1/R	Ø 164	805	1640,5	1170	935	700	268	1363	350	10	350	10	400/350 3"	350-200	350	-
○KCD350RS+021082N1	Ø 164	785	1640,5	1170	935	700	268	-	350	10	350	10	400/350 3"	-	-	350
●KCD350RP+025082N1/R	Ø 164	990	1662,5	1170	935	700	268	1375	350	10	350	10	400/350 3"	350-225	350	-
○KCD350RO+025082N1	Ø 164	970	1662,5	1170	935	700	268	-	350	10	350	10	400/350 3"	-	-	350
●KCD350RH+034082N1/R	Ø 164	1025	1662,5	1170	935	700	268	1375	350	10	350	10	400/350 3"	350-225	350	-
○KCD350RG+034082N1	Ø 164	1070	1662,5	1170	935	700	268	-	350	10	350	10	400/350 3"	-	-	350
●KCD350RB+042082N1/R	Ø 164	1175	1672,5	1170	935	700	268	1385	350	10	350	10	400/350 3"	350-250	350	-
○KCD350RA+042082N1	Ø 164	1155	1672,5	1170	935	700	268	-	350	10	350	10	400/350 3"	-	-	350

BAK.			a	b	c	d	e	f	g	h	i	j	l	m	n	o	r	t	y	z
BAK400/350 3"			157,5	12,5	35	3"	525	117	320	920	575	24	95	810	400	510	400	10	767	1577
SOK.			a3	f3	g3	h3	i3	k3	l3	m3	n3	o3								
SOK350-200			3	530	22	500	160	270	100	22	40	85								
SOK350-225			3	530	22	500	160	270	100	22	40	85								
SOK350-250			3	530	22	500	160	270	100	22	40	85								
TSK.A/R			a2	b2	c2	d2	e2	f2	g2	h2	i2	j2	k2	n2	w2					
TSK350A/R			345	540	280	600	6	22	850	1000	740	935	1000	540	505					
TSK.B/R			n2	s2	t2	u2	w2	y2	z2											
TSK350B/R			540	280	1000	1000	505	740	1550											

(3) z = Minimum submergence depth for motor without casing with continuous duty S1 (NPSHR permitting)

(3) z = Immersion minimum pour moteur sans chemise en service continu S1 (compatible avec le NPSHR)

(3) z = Immersion minima per motore senza mantello in funzione continuo S1 compatibilmente con l'NPSHR

y = Minimum submergence depth for motor without casing with intermittent duty S3 (NPSHR permitting)

y = Immersion minimum pour moteur sans chemise en service intermittent S3 (compatible avec le NPSHR)

y = Immersion minima con motore senza mantello in funzione intermittente S3 compatibilmente con l'NPSHR

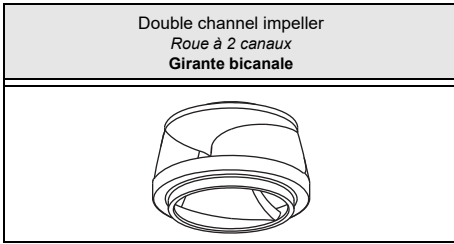

Type Type Tipo	KCD350R...62N3	
Thermal probes Sondes termiques Sonde termiche	Yes Oui Sì	
Conductivity probe Sonde de conductivité Sonda di conduttività	Yes Oui Sì	

Version cable (1)
Version câble (1)
Cavo Versione (1)

Electric pump type Electropompe type Elettropompa tipo	Power supply Alimentation Alimentazione	Auxiliary Auxiliaire Ausiliario
KCD350RW+042062N3/R	2x(4x16)x10	1x(4x1,5)x10
KCD350RV+042062N3	2x(4x16)x10	1x(4x1,5)x10
KCD350RT+051062N3/R	2x(4x25)x10	1x(4x1,5)x10
KCD350RS+051062N3	2x(4x25)x10	1x(4x1,5)x10

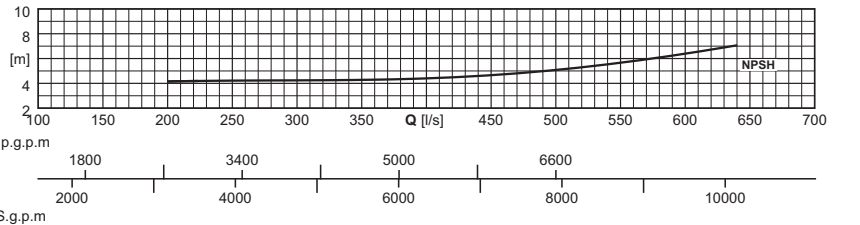
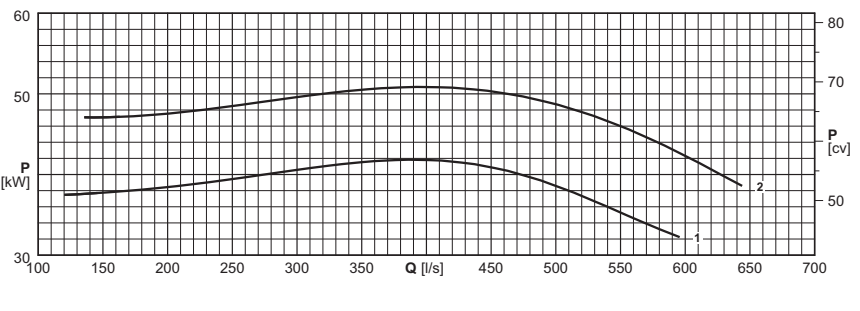
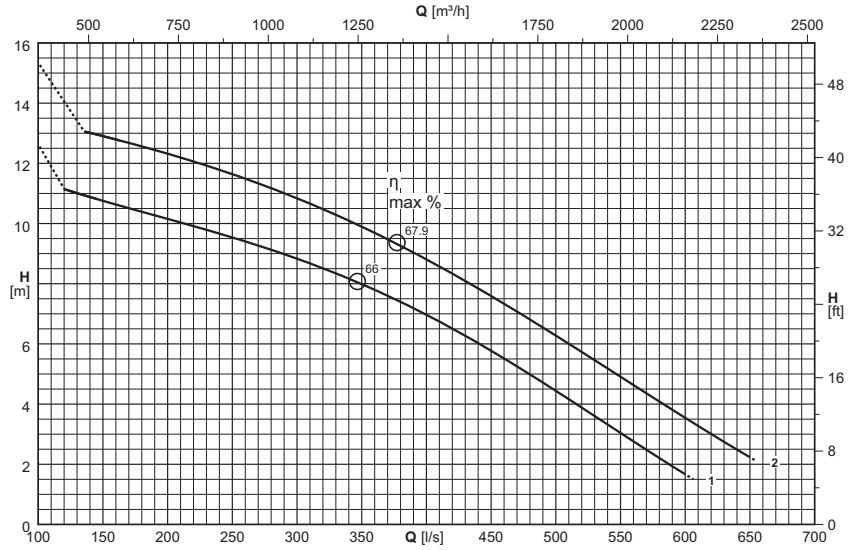

(1) = n°. of cables x (n°. of wires each cable x size [mm²]) x cable length [m] - Câble NSSHOU-J
Cable length exceeding 10 m on request

(1) = n°. câbles x (n°. conducteurs câble x section [mm²]) x longueur câble [m] - Câble NSSHOU-J
Sur demande longueur de câble supérieure à 10 m

(1) = n°. cavi x (n°. conduttori per cavo x sezione [mm²]) x lunghezza cavo [m] - Cavo NSSHOU-J
Lunghezza cavo superiore a 10 m - su richiesta

Electric pump type Electropompe type Elettropompa tipo	Curve Courbe Curva	Motor power Puiss. moteur Potenza motore	Capacity Debit Portata															
			[l/s]	0	130	150	175	200	250	300	350	400	450	500	550	600	650	655
			P ₂	[m³/h]	0	468	540	630	720	900	1080	1260	1440	1620	1800	1980	2160	2340
	(N°)	[kW]	Head Hauteur Prevalenza															
●KCD350RW+042062N3/R	1	42	[m]	12,6	11	10,8	10,5	10,2	9,5	8,8	8	7	5,8	4,4	3	1,7		
○KCD350RV+042062N3/(R)	1	42	[m]	12,6	11	10,8	10,5	10,2	9,5	8,8	8	7	5,8	4,4	3	1,7		
●KCD350RT+051062N3/R	2	51	[m]	15,3		12,9	12,6	12,3	11,6	10,8	9,9	8,8	7,6	6,3	4,9	3,5	2,2	2,1
○KCD350RS+051062N3/(R)	2	51	[m]	15,3		12,9	12,6	12,3	11,6	10,8	9,9	8,8	7,6	6,3	4,9	3,5	2,2	2,1
NPSH _R			[m]			4	4,1	4,1	4,2	4,2	4,3	4,4	4,7	5,1	5,7	6,4	7,3	7,3

● Fixed installation in a dry chamber (R)
○ Submersible version
P₂ = Power rated by the motor
Performance tolerance as per:
UNI/ISO 9906 Grade 3B

(2) For models in the explosion-proof version KCD350R(X)
For motor performances specification see page "motor features"

For the accessories specification see page "Accessories"
The impellers will be trimmed to meet the duty point

● Installation fixe en fosse sèche (R)
○ Version immergée
P₂ = Puissance restituée par le moteur
Tolérances sur les performances selon normes:
UNI/ISO 9906 Niveau 3B

(2) Pour les modèles version antidéflagrante KCD350R(X)
Pour caractéristiques techniques moteurs voir page "Caractéristiques des moteurs"

Pour les accessoires voir page "Accessories"
Le point de fonctionnement désiré peut être obtenu par rognage de roue

● Esecuzione per camera asciutta (R)
○ Esecuzione Immersa
P₂ = Potenza resa dal motore
Tolleranze sulle prestazioni secondo norme:
UNI/ISO 9906 Grado 3B

(2) Versione antideflagrante vedere KCD350R(X)
Per caratteristiche motori vedere pagina "caratteristiche motori"

Per accessori vedere pagina accessori
Le giranti vengono tornite in modo da ottenere il punto di lavoro richiesto

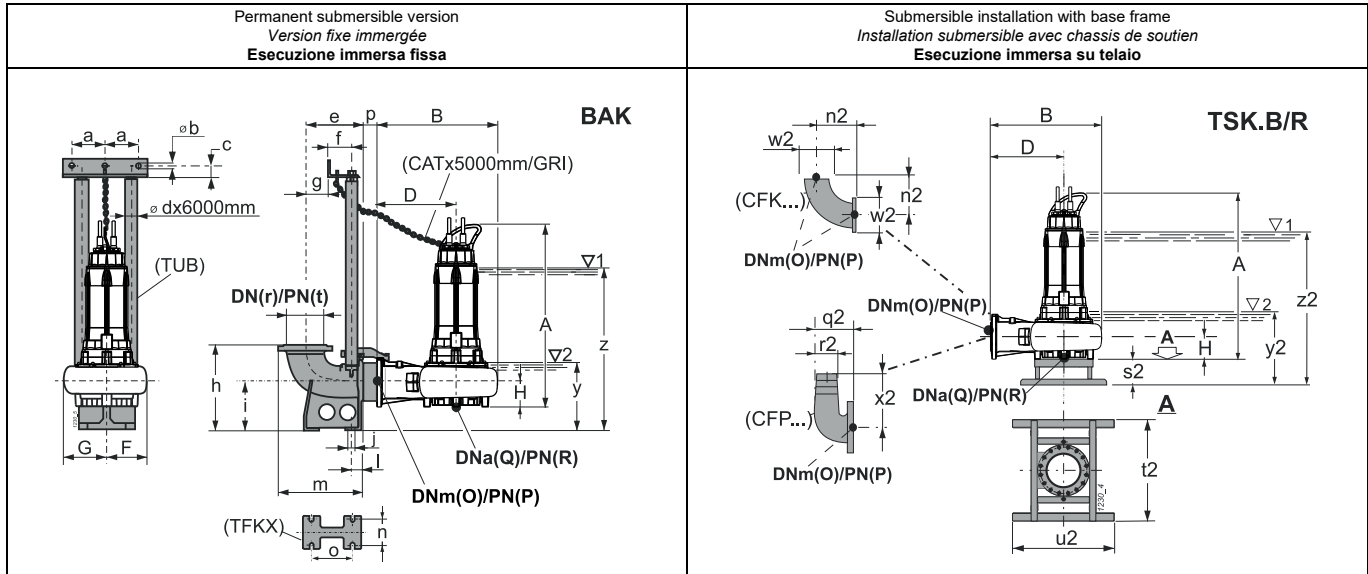

For fixed installation in a dry chamber - vertical (R)
Pour installation fixe en fosse sèche - verticale (R)
Esecuzione per camera asciutta - verticale (R)

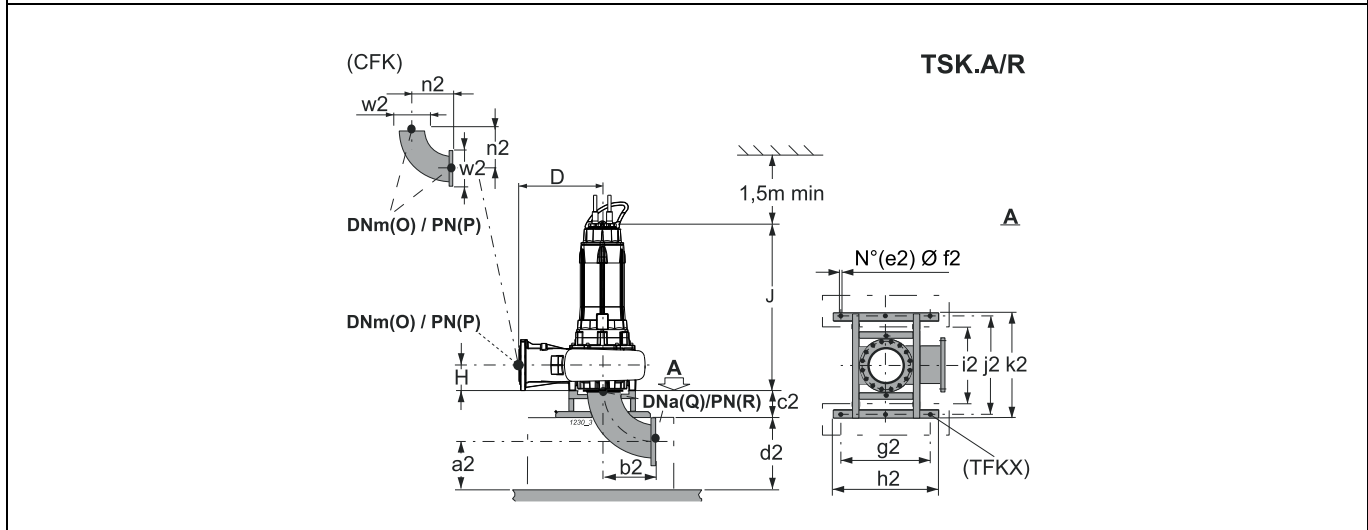

Type Type Tipo	Free passage Passage libre Passaggio Libero	Weight Poids Peso	[mm]												Accessories Accessoires Accessori				
			A	B	D	F	G	H	J	O	P	Q	R	BAK.	TSK.A/R	TSK.B/R			
●KCD350RW+042062N3/R	∅ 164	988,3	-	-	700	-	-	268	1470	350	10	350	10	-	350	-			
○KCD350RV+042062N3	∅ 164	950	1704	1170	700	385	550	268	-	350	10	350	10	S400/350 3"	-	350			
●KCD350RV+042062N3/R	∅ 164	988,3	1704	1170	700	385	550	268	-	350	10	350	10	S400/350 3"	-	350			
●KCD350RT+051062N3/R	∅ 164	1090,25	-	-	700	-	-	268	1503	350	10	350	10	-	350	-			
○KCD350RS+051062N3	∅ 164	1053,15	1737	1170	700	385	550	268	-	350	10	350	10	S400/350 3"	-	350			
●KCD350RS+051062N3/R	∅ 164	1091,5	1737	1170	700	385	550	268	-	350	10	350	10	S400/350 3"	-	350			
BAK.	a	b	c	d	e	f	g	h	i	j	l	m	n	o	p	r	t	y	z
BAKS400/350 3"	157,5	12,5	35	3"	525	117	320	920	575	24	95	810	400	510	50	400	10	765	1618
TSK.A/R	a2	b2	c2	d2	e2	f2	g2	h2	i2	j2	k2	n2	w2						
TSK350A/R	345	540	280	600	6	22	850	1000	740	935	1000	540	505						
TSK.B/R	n2	s2	t2	u2	w2	y2	z2												
TSK350B/R	540	280	1000	1000	505	738	1591												

(3) z = Minimum submergence depth for motor without casing with continuous duty S1 (NPSHR permitting)
y = Minimum submergence depth for motor without casing with intermittent duty S3 (NPSHR permitting)

(3) z = Immersion minimum pour moteur sans chemise en service continu S1 (compatible avec le NPSHR)
y = Immersion minimum pour moteur sans chemise en service intermittent S3 (compatible avec le NPSHR)

(3) z = Immersion minima per motore senza mantello in funzione continuo S1 compatibilmente con l'NPSHR
y = Immersione minima con motore senza mantello in funzione intermittente S3 compatibilmente con l'NPSHR

The following are also available: Anchoring bolts, level regulators and Electric panels

Accessoires supplémentaires: Tire-fond, Régulateurs de niveau et coffrets électriques

Sono inoltre disponibili: tirafondi, regolatori di livello e quadri elettrici

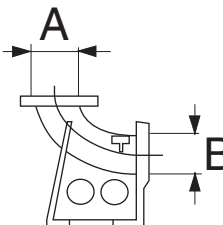
Duck-foot pedestal for automatic coupling (*) <i>Pied d'assise pour accouplement automatique (*)</i> Piede di accoppiamento automatico (*)	Type Type Tipo	A		B		Weight Poids Peso [Kg]	Electric pump type <i>Electropompe type</i> Elettropompa tipo					
		DN	UNI PN	DN	UNI PN		KCM150R	KCM250R	KCM250Z	KCD300R	KCD300Z	KCD350R
	BAK300/250 3"	300	10	250	10	160	-	•	•	-	-	-
	BAK350/300 3"	350	10	300	10	230	-	-	-	•	•	-
	BAK400/350 3"	400	10	350	10	310	-	-	-	-	-	•
	BAKM/I 3"	200	10	150	16	88	•	-	-	-	-	-
	BAKS400/350 3"	400	10	350	10	318	-	-	-	-	-	•

(*) = Complete with:

Pump coupling bracket (nodular cast iron)

Rail pipes anchor bracket (stainless steel)

Screw and nuts

(*) = Composé de:

Support de guidage (fonte à graphite sphéroïdale)

Support de barre de guidage (acier inox)

Visserie

(*) = Completo di:

Staffa corpo premente (ghisa sferoidale)

Staffa per tubi guida (acciaio inox)



Minuteria

Rail pipes (*) (dipped galvanized steel) <i>Barres de guidage (*) (acier galvanisé à chaud)</i> Tubi guida (*) (acciaio zincato a caldo)	Type Type Tipo	Weight Poids Peso [Kg]	Electric pump type <i>Electropompe type</i> Elettropompa tipo					
			KCM150R	KCM250R	KCM250Z	KCD300R	KCD300Z	KCD350R
	TUB 3"	51	•	•	•	•	•	•

(*) = On demand: stainless steel

(*) = Sur demande: acier inox

(*) = Su richiesta: acciaio inox

Chain and Shackle Kit (*) <i>Kit Chaîne et manille (*)</i> Kit Catena e Grillo (*)	Type Type Tipo	Max load <i>Portée max</i> Portata max [Kg]	Length <i>Longueur</i> Lunghezza [m]	Electric pump type <i>Electropompe type</i> Elettropompa tipo					
				KCM150R	KCM250R	KCM250Z	KCD300R	KCD300Z	KCD350R
CAT  GRI 	CAT D.14 / GRL D.16	2500	5	•	•	•	•	•	•

(*) = On demand: stainless steel

(*) = Sur demande: acier inox

(*) = Su richiesta: acciaio inox

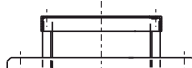
Base frame (dipped galvanized steel) <i>Chassis de soutien (acier galvanisé)</i> Telaio di sostegno (acciaio zincato a caldo)	Type Type Tipo	Weight Poids Peso [Kg]	Electric pump type <i>Electropompe type</i> Elettropompa tipo					
			KCM150R	KCM250R	KCM250Z	KCD300R	KCD300Z	KCD350R
	TSK150B/R	46	•	-	-	-	-	-
	TSK350B/R	53	-	•	•	•	•	•

Flanged hose connection (dipped galvanized steel) <i>Coude pour tuyauterie souple (acier galvanisé à chaud)</i> Curva flangiata portagomma (acciaio zincato a caldo)	Type Type Tipo	Weight Poids Peso [Kg]	Electric pump type <i>Electropompe type</i> Elettropompa tipo					
			KCM150R	KCM250R	KCM250Z	KCD300R	KCD300Z	KCD350R
	CFP150	18	•	-	-	-	-	-
	CFP250	51	-	•	•	-	-	-

Supports (Steel with protective paint) <i>Support de soutien (Acier revêtu de peinture de protection)</i> Supporti (acciaio con vernice protettiva)	Type Type Tipo	Weight Poids Peso [Kg]	Electric pump type <i>Electropompe type</i> Elettropompa tipo					
			KCM150R	KCM250R	KCM250Z	KCD300R	KCD300Z	KCD350R
	SOK350-200	73	-	-	21	-	17-21	21
	SOK350-225	73	-	-	-	-	-	25-34
	SOK350-250	73	-	-	-	-	-	42

Base frame (dipped galvanized steel) <i>Chassis de soutien (acier galvanisé)</i> Telaio di sostegno (acciaio zincato a caldo)	Type Type Tipo	A		B		Weight Poids Peso [Kg]	Electric pump type <i>Electropompe type</i> Elettropompa tipo					
		DN	UNI PN	DN	UNI PN		KCM150R	KCM250R	KCM250Z	KCD300R	KCD300Z	KCD350R
	TSK150A/R	150	16	150	16	80	●	-	-	-	-	-
	TSK250A/R	250	10	250	10	101	-	●	●	-	-	-
	TSK300A/R	300	10	300	10	116	-	-	-	●	●	-
	TSK350A/R	350	10	350	10	128	-	-	-	-	-	●

(*) = Fixed installation in a dry chamber

(*) = Installation fixe en fosse

(*) = Esecuzione per camera asciutta

Flanged elbow (dipped galvanized steel) <i>Coude bridé (acier galvanisé à chaud)</i> Curva flangiata (acciaio zincato a caldo)	Type Type Tipo	A		B		Weight Poids Peso [Kg]	Electric pump type <i>Electropompe type</i> Elettropompa tipo					
		DN	UNI PN	DN	UNI PN		KCM150R	KCM250R	KCM250Z	KCD300R	KCD300Z	KCD350R
	CFK150	150	16	150	16	25,5	●	-	-	-	-	-
	CFK250	250	10	250	10	43,5	-	●	●	-	-	-
	CFK300	300	10	300	10	62	-	-	-	●	●	-
	CFK350	350	10	350	10	87,5	-	-	-	-	-	●

50 Hz motor features (*N)
Caractéristiques des moteurs à 50 Hz (*N)
Caratteristiche motori a 50 Hz (*N)

Poles Pôles Poli	Motor type Moteur type Motore tipo	Motor power Puiss. moteur Potenza motore		Absorption Intensité Assorbimento	Direct starting Démarrage direct Avviamento diretto	Direct starting2 Démarrage direct2 Avviamento diretto2		Starts / hour max Max démarrages / heure Max avviamenti/ora	Degree of intermittence Degré d'intermittence Grado di intermittenza
		P ₁	P ₂	IN (400V)		(Standard)			
		[kW]		[A]		I _S /I _N	Direct Direct Diretto		
8	KC01708..Z200..	19,5	17	36	5,8	●	●	10	-
	KC02108..R200..	24,2	21	44,1	5,6	●	●	10	-
	KC02108..Z200..	24,2	21	44,1	5,6	●	●	10	-
	KC02508..R225..	29,4	25	58,5	4,5	●	●	10	-
	KC03408..R225..	40	34	80	4,4	●	●	10	-
	KC04208..R250..	48,7	42	90,5	4	●	●	10	-
6	KC02506..R225..	27,5	25	49	7,89	●	●	10	-
	KC03406..R225..	37,15	34	64,6	5,98	●	●	10	-
	KC04206..R250..	46	42	76,5	6,49	●	●	10	-
	KC05106..R280..	55,4	51	91	6,66	●	●	10	-
4	KC03404..R225..	36,8	34	62,5	8,76	●	●	10	-
	KC04204..R225..	45,5	42	75,5	7,25	●	●	10	-
	KC05104..R225..	55	51	90,5	7,15	●	●	10	-
	KC06204..R250..	66,6	62	109,5	6,94	●	●	10	-
	KC08204..R280..	87,25	82	142	6,88	●	●	10	-

*N = Standard version

P₁ = Power absorbed by the motor

P₂ = Power rated by the motor

I_N = Rated current

I_S = Starting current

- The electric pumps are suitable for S1 continuous service with submersed motor and for S3 intermittent service (see relative degrees of intermittence in the table) with non-submersed motor.

S3 service stands for intermittent service consisting of 10 minute equal cycles of which the previous table indicates the minutes of the cycle during which the motor may operate (eg. : S3 = 25%. operation consists of a repetitive sequence of 2,5 minutes operation and 7,5 minutes at a standstill). See standard CEI EN 60034-1

- The electric motors are produced in the following voltage ratings: 400 V ± 10% standard; 230 V ± 10% on request.

Other voltages on request.

*N = Version standard

P₁ = Puissance absorbée par le moteur

P₂ = Puissance restituée par le moteur

I_N = Intensité nominale

I_S = Intensité au démarrage

- L'électropompe est apte à fonctionner en service continu S1 avec le moteur complètement immergé, en service intermittent S3 moteur non immergé (se reporter aux valeurs d'intermittence mentionnées dans le tableau).

Le service S3 indique un fonctionnement intermittent par cycles identiques de 10 minutes. Le tableau ci-dessus indique le temps de marche du moteur en minutes pour 1 cycle de 10 minutes (Ex. : S3 = 25% chaque cycle sera composé de 2,5 minutes de marche et de 7,5 minutes d'arrêt). Voir norme CEI EN 60034-1.

- Les moteurs électriques prévus doivent être alimentés aux tensions nominales suivantes: 400 V ± 10% standard; 230 V ± 10% sur demande.

Tensions différentes sur demande.

*N = Versione standard

P₁ = Potenza assorbita motore

P₂ = Potenza resa dal motore

I_N = Corrente nominale

I_S = Corrente di avviamento

- Le elettropompe sono atte a funzionare in servizio continuo S1 con motore immerso, in servizio intermittente S3 con motore non immerso (vedi relativi gradi di intermittenza nella tabella).

Il servizio S3 sta ad indicare un funzionamento intermittente composto da cicli tutti uguali di 10 minuti di cui si indicano i minuti del ciclo in cui il motore può funzionare (Es. : S3 = 25% il funzionamento è composto da una sequenza ripetitiva di 2,5 minuti di funzionamento e di 7,5 minuti di sosta). Vedi norma CEI EN 60034-1.

- I motori elettrici sono previsti per essere alimentati alle seguenti tensioni nominali di rete: 400 V ± 10% standard; 230 V ± 10% a richiesta.

Tensioni diverse su richiesta.

K+

DN 150÷350



Performance ranges
Champs de performance
Campi di prestazione

- KCM150R(X)
- KCM250R(X)
- KCM250Z(X)
- KCD300R(X)
- KCD300Z(X)
- KCD350R(X)

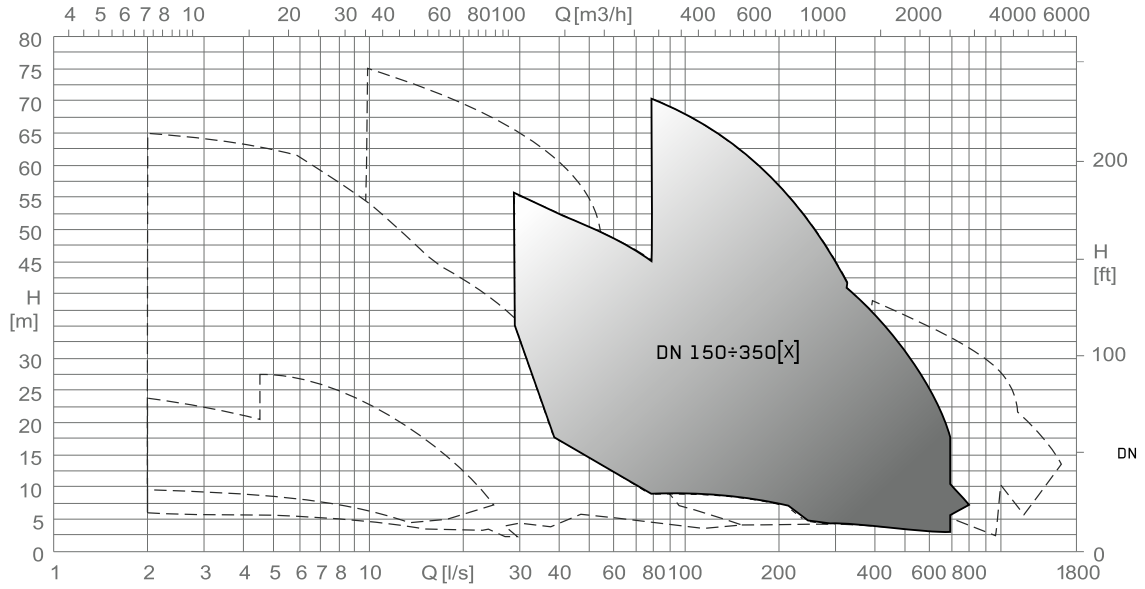

[Imp.g.p.m.] 20 30 40 60 100 200 400 600 1000 2000 6000 10000 20000

[US.g.p.m.] 20 30 40 60 100 200 400 600 1000 2000 4000 10000 20000

[l/min] 60 100 200 400 600 1000 2000 6000 10000 20000 40000 100000

K+

DN 150÷350

caprari

Construction and materials
Construction et matériaux
Costruzione e materiali

KCM150R(X)
KCM250R(X)
KCM250Z(X)
KCD300R(X)
KCD300Z(X)
KCD350R(X)

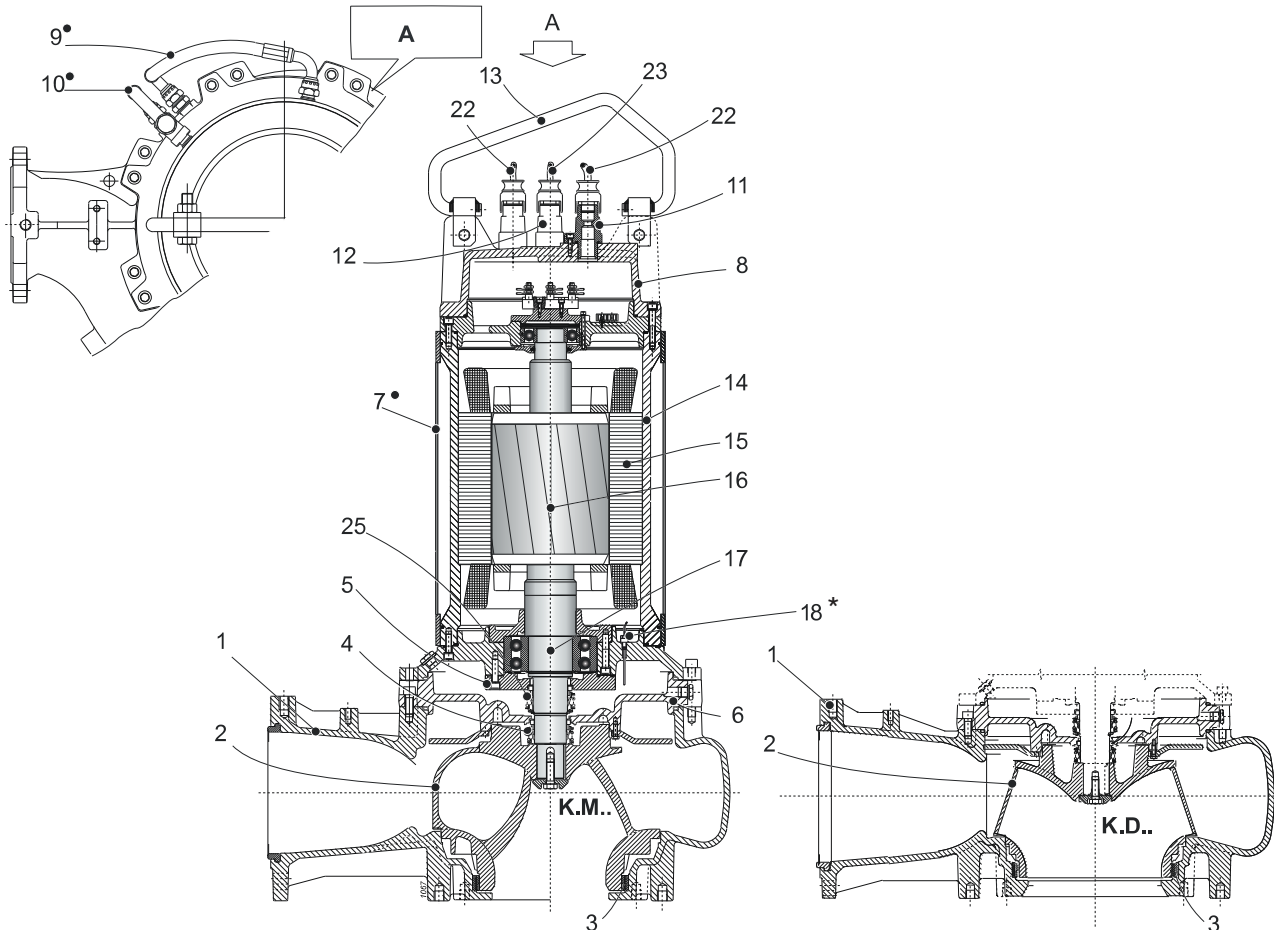

Pos.	Parts	Materials	Nomenclature	Matériaux	Nomenclatura	Materiale
1	Delivery body	Cast iron	Corps de refoulement	Fonte grise	Corpo mandata	Ghisa grigia
2	Impeller	Cast iron	Roue	Fonte grise	Girante	Ghisa grigia
3	Impeller wear ring	Steel/Rubber	Bague d'usure	Acier/Caoutchouc	Anello sede girante	Acciaio/Gomma
4	Mechanical seal on pump side	Silicon carbide/silicon carbide	Garniture mécanique côté pompe	Carbure de silicium/ carbure de silicium	Tenuta meccanica lato pompa	Carburo di silicio/ carburo di silicio
5	Support bearing	Nodular cast iron	Support de roulement	Fonte sphéroïdale	Supporto cuscinetto	Ghisa sferoidale
6	Oil box	Cast iron	Chambre à huile	Fonte grise	Scatola olio	Ghisa grigia
7•	Cooling jacket	Stainless steel	Chemise	Acier inox	Mantello	Acciaio inox
8	Head cover	Cast iron	Couvercle tête	Fonte grise	Coperchio testata	Ghisa grigia
9 - 10•	Cooling pipe	Stainless steel/PTFE	Tuyau de refroidissement	Acier inox/PTFE	Tubo di raffreddamento	Acciaio inox/PTFE
11 - 12	Cable clamp	Cast iron	Presse-étoupe	Fonte grise	Pressacavo	Ghisa grigia
13	Handle	Stainless steel	Poignée	Acier inox	Maniglia	Acciaio inox
14	Motor casing	Cast iron	Enveloppe du moteur	Fonte grise	Carcassa motore	Ghisa grigia
15	Stator	Electrical steel	Stator	Tôle magnétique	Statore	Lamierino magnetico
16	Rotor	Electrical steel	Rotor	Tôle magnétique	Rotore	Lamierino magnetico
17	Shaft	Stainless steel	Arbre	Acier inox	Albero	Acciaio inox
18*	Conductivity probe	-	Sondes de conductivité	-	Sonda di conduttività	-
22	Round power cable	-	Câble rond d'alimentation	-	Cavo tondo di alimentazione	-
23	Round auxiliary cable	-	Câble rond auxiliaire	-	Cavo tondo ausiliario	-
25	Mechanical seal on motor side	Stainless steel/graphite	Garniture mécanique côté moteur	Acier inox/graphite	Tenuta meccanica lato motore	Acciaio inox/grafite

* For explosion-proof versions (X);
Conductivity probe in the motor casing.

• Cooling system components (Version .../R)

Screws and nuts in stainless steel.

Available version with AISI 316 stainless steel impeller.

* Pour version antidéflagrantes (X);

Sonde de conductivité dans l'enveloppe du moteur.

• Composant pour version avec système de refroidissement
(Version .../R)

Vis et écrous en acier inox

Disponible version Avec roue en acier inox AISI 316.

* Per versioni antideflagranti (X);

Sonda di conduttività nella carcassa motore.

• Componenti sistema di raffreddamento (Versione .../R)

Viti e dadi in acciaio inox

Disponibile versione con girante in acciaio inox AISI 316.

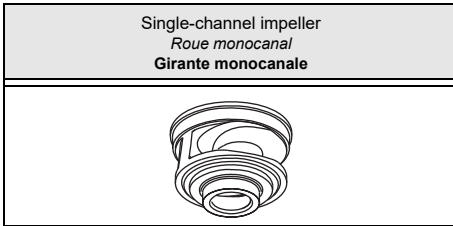

Type Type Tipo	KCM150R...+...42X1	
Thermal probes Sondes thermiques Sonda termiche	Yes Oui Sì	
Conductivity probe Sonde de conductivité Sonda di conduttività	Yes Oui Sì	

Version cable (1) Version câble (1) Cavo Versione (1)		
Electric pump type Electropompe type Elettropompa tipo	Power supply Alimentation Alimentazione	Auxiliary Auxiliaire Ausiliario
KCM150RM+030042X1	2x(4x10)x10	1x(5x1,5)x10
KCM150RH+037042X1	2x(4x10)x10	1x(5x1,5)x10
KCM150RE+045042X1	2x(4x16)x10	1x(5x1,5)x10
KCM150RB+055042X1	2x(4x25)x10	1x(5x1,5)x10

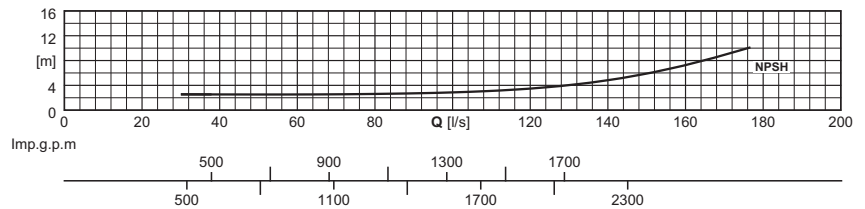
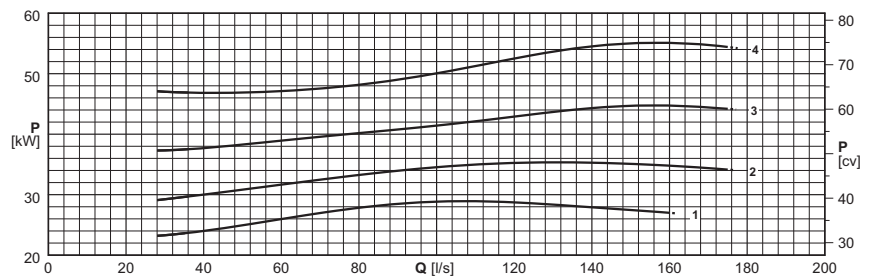
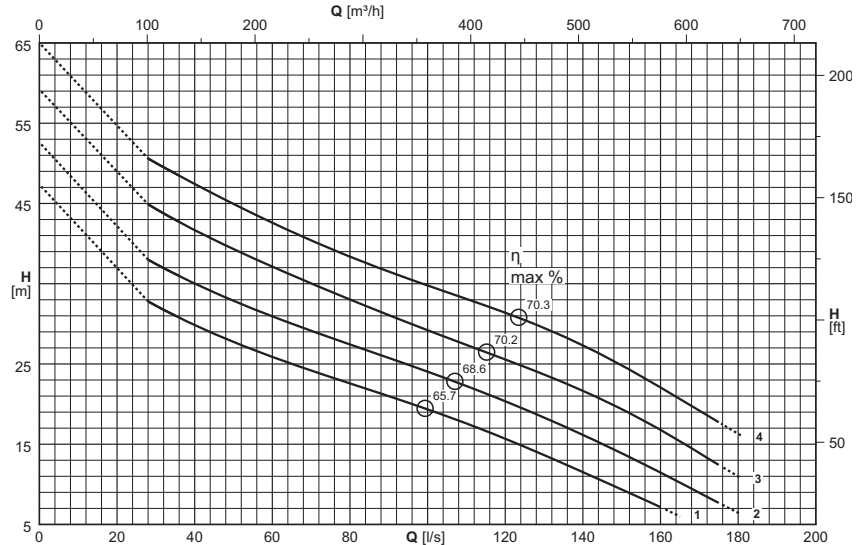

(1) = n°. of cables x (n°. of wires each cable x size [mm²]) x cable length [m] - Câble H07RN-F (OZOFLEX Plus)
Cable length exceeding 10 m on request

(1) = n°. câbles x (n°. conducteurs câble x section [mm²]) x longueur câble [m] - Câble H07RN-F (OZOFLEX Plus)
Sur demande longueur de câble supérieure à 10 m

(1) = n°. cavi x (n°. conduttori per cavo x sezione [mm²]) x lunghezza cavo [m] - Cavo H07RN-F (OZOFLEX Plus)
Lunghezza cavo superiore a 10 m - su richiesta

Electric pump type Electropompe type Elettropompa tipo	Curve Courbe Curva	Motor power Puiss. moteur Potenza motore	Capacity Débit Portata																
			[l/s]	0	30	35	40	45	50	60	70	80	90	100	125	150	175	180	
(2)	(N°)	[kW]	[m³/h]	0	108	126	144	162	180	216	252	288	324	360	450	540	630	648	
			Head Hauteur Prevalenza																
			[m]	42,4	32,3	31	29,9	28,8	27,8	25,9	24,2	22,6	21	19,3	14,7	9,4			
KCM150RM+030042X1	1	30	[m]	42,4	32,3	31	29,9	28,8	27,8	25,9	24,2	22,6	21	19,3	14,7	9,4			
KCM150RH+037042X1	2	37	[m]	47,6	37,5	36,2	35,1	33,9	32,9	30,9	29,1	27,4	25,7	24	19,3	13,9	7,7	6,5	
KCM150RE+045042X1	3	45	[m]	54,2	44,4	43	41,7	40,5	39,3	37,1	35	33	31,1	29,2	24,6	19,3	12,4	11	
KCM150RB+055042X1	4	55	[m]	62,1	50,1	48,7	47,4	46,2	45	42,6	40,4	38,4	36,5	34,8	30,5	24,8	17,7	16,3	
NPSH _R			[m]		2,6	2,5	2,5	2,5	2,5	2,5	2,6	2,6	2,7	2,9	3,7	5,9	9,8	10,7	

P₂ = Power rated by the motor
Performance tolerance as per:
UNI/ISO 9906 Grade 3B

For models in the ATEX II 2G Ex db h IIB T4 Gb and I M2 Ex db h I Mb
For motor performances specification see page "motor features"

For the accessories specification see page "Accessories"

P₂ = Puissance restituée par le moteur
Tolérances sur les performances selon normes:
UNI/ISO 9906 Niveau 3B

Pour les modèles version antidéflagrante ATEX II 2G Ex db h IIB T4 Gb et I M2 Ex db h I Mb
Pour caractéristiques techniques moteurs voir page "Caractéristiques des moteurs"

Pour les accessoires voir page "Accessories"

P₂ = Potenza resa dal motore

Tolleranze sulle prestazioni secondo norme:
UNI/ISO 9906 Grado 3B

Versione antidéflagrante ATEX II 2G Ex db h IIB T4 Gb e I M2 Ex db h I Mb
Per caratteristiche motori vedere pagina "caratteristiche motori"

Per accessori vedere pagina accessori

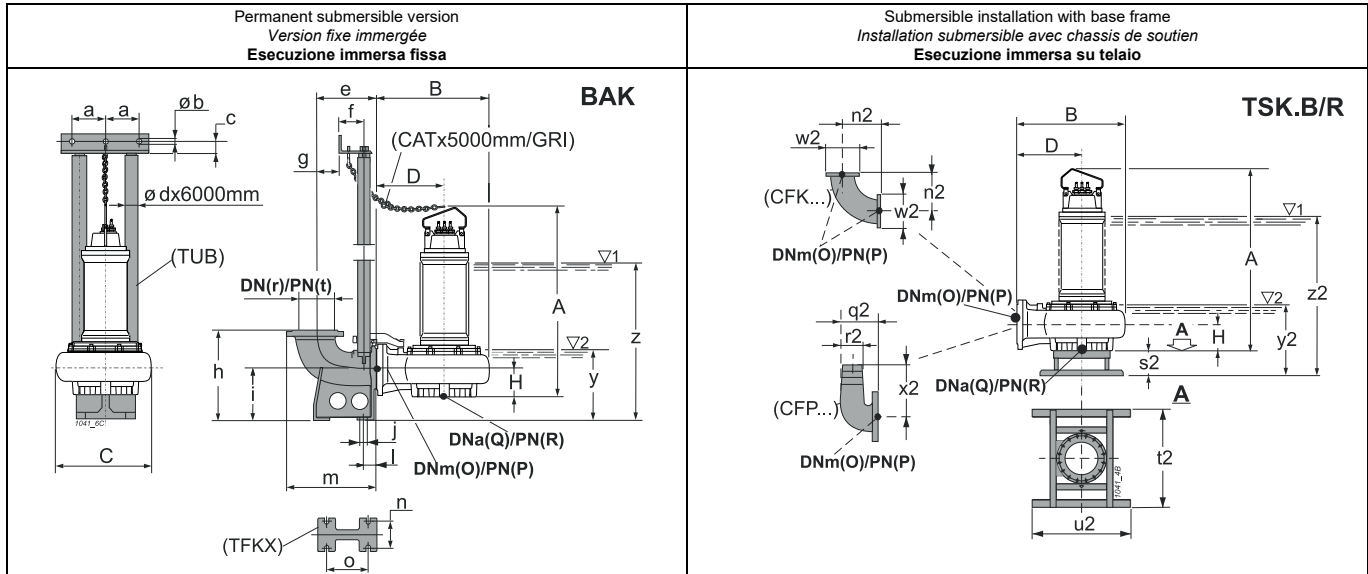

For fixed installation in a dry chamber - vertical (R)
Pour installation fixe en fosse sèche - verticale (R)
Esecuzione per camera asciutta - verticale (R)

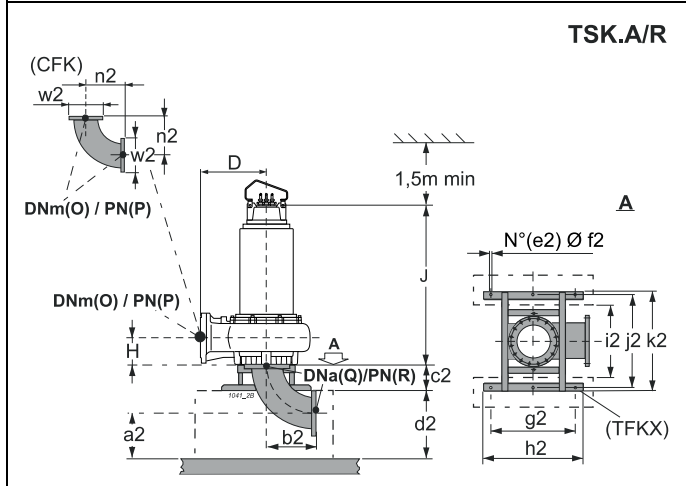

For fixed installation in a dry chamber - horizontal (R)
Pour installation fixe en fosse sèche - horizontale (R)
Esecuzione per camera asciutta - orizzontale (R)

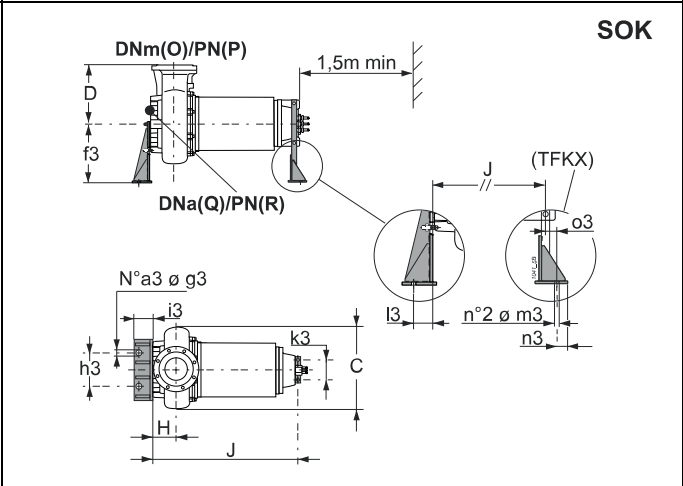

Type Type Tipo	Free passage Passage libre Passaggio Libero	Weight Poids Peso	A	B	C	D	H	J	O	P	Q	R	Accessories Accessoires Accessori			
			[mm]	[kg]	[mm]										BAK.	SOK.
KCM150RM+030042X1	Ø 102	567	1559,5	825	670	500	195	-	150	16	150	16	M/I 3"	-	-	150
KCM150RM+030042X1/R	Ø 102	582	1559,5	825	670	500	195	1282	150	16	150	16	M/I 3"	150-200	150	-
KCM150RH+037042X1	Ø 102	582	1559,5	825	670	500	195	-	150	16	150	16	M/I 3"	-	-	150
KCM150RH+037042X1/R	Ø 102	597	1559,5	825	670	500	195	1282	150	16	150	16	M/I 3"	150-200	150	-
KCM150RE+045042X1	Ø 102	812	1581,5	825	670	500	195	-	150	16	150	16	M/I 3"	-	-	150
KCM150RE+045042X1/R	Ø 102	822	1581,5	825	670	500	195	1294	150	16	150	16	M/I 3"	150-225	150	-
KCM150RB+055042X1	Ø 102	942	1591,5	825	670	500	195	-	150	16	150	16	M/I 3"	-	-	150
KCM150RB+055042X1/R	Ø 102	962	1591,5	825	670	500	195	1304	150	16	150	16	M/I 3"	150-250	150	-

BAK.	a	b	c	d	e	f	g	h	i	j	l	m	n	o	r	t	y	z
BAKM/I 3"	157,5	12,5	35	3"	385	117	180	540	290	24	80	555	210	280	200	10	250	995
SOK.	a3	f3	g3	h3	i3	k3	l3	m3	n3	o3								
SOK150-200	3	530	22	335	160	270	100	22	40	85								
SOK150-225	3	530	22	335	160	270	100	22	40	85								
SOK150-250	3	530	22	335	160	270	100	22	40	85								
TSK.A/R	a2	b2	c2	d2	e2	f2	g2	h2	i2	j2	k2	n2	w2 <td colspan="5"></td>					
TSK150A/R	285	395	280	400	6	22	850	1000	740	935	1000	395	285					
TSK.B/R	n2	q2	r2	s2	t2	u2	w2	x2	y2	z2 <td colspan="8"></td>								
TSK150B/R	395	315	150	280	1000	1000	285	380	435	1180								

(3) z = Minimum submergence depth for motor without casing with continuous duty S1 (NPSHR permitting)

(3) z = Immersion minimum pour moteur sans chemise en service continu S1 (compatible avec le NPSHR)

(3) z = Immersion minima per motore senza mantello in funzione continuo S1 compatibilmente con l'NPSHR

y = Minimum submergence depth for motor without casing with intermittent duty S3 (NPSHR permitting)

y = Immersion minimum pour moteur sans chemise en service intermittent S3 (compatible avec le NPSHR)

y = Immersion minima con motore senza mantello in funzione intermittente S3 compatibilmente con l'NPSHR

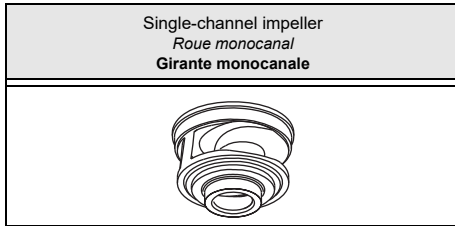

Type Type Tipo	KCM250Z...+...82X1	
Thermal probes <i>Sondes thermiques</i> Sonda termiche	Yes <i>Oui</i> SI	
Conductivity probe <i>Sonde de conductivité</i> Sonda di conduttività	Yes <i>Oui</i> SI	

Version cable (1)
Version câble (1)
Cavo Versione (1)

Electric pump type <i>Electropompe type</i> Elettropompa tipo	Power supply <i>Alimentation</i> Alimentazione	Auxiliary <i>Auxiliaire</i> Ausiliario
KCM250ZD+018582X1	2x(4x6)x10	1x(5x1,5)x10

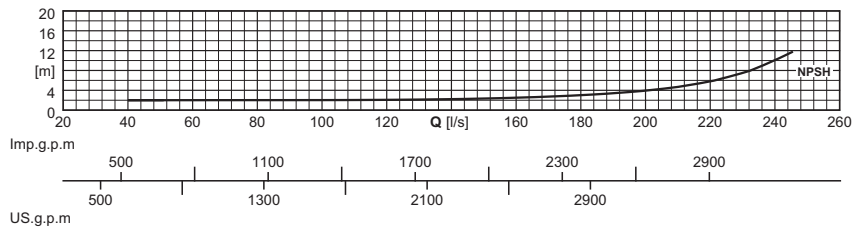
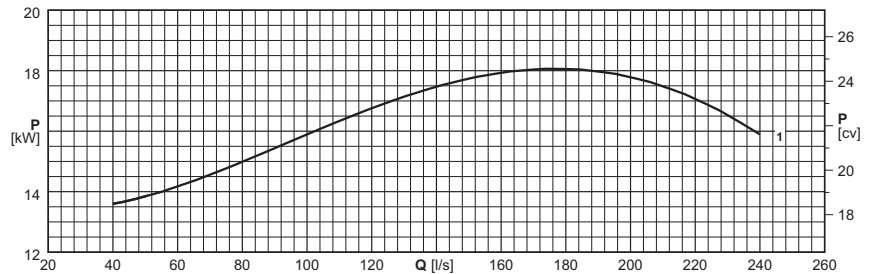
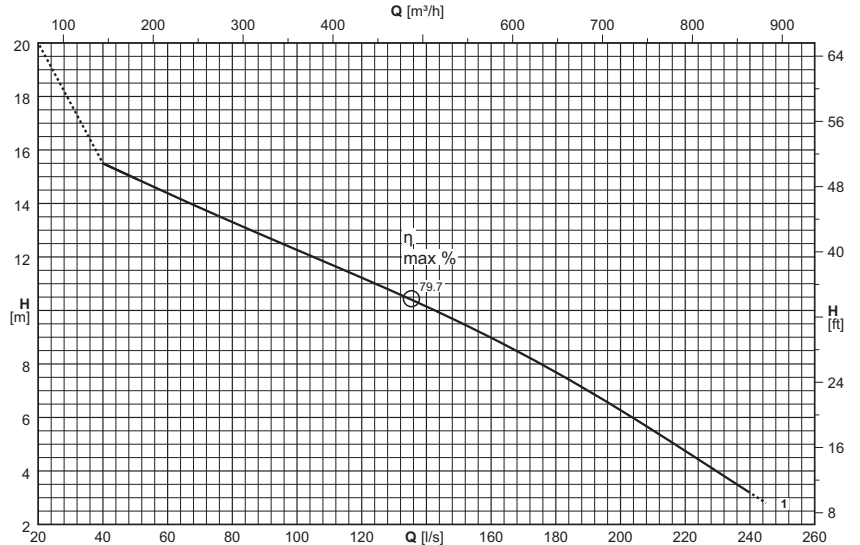

(1) = n°. of cables x (n°. of wires each cable x size [mm²]) x cable length [m] - Câble H07RN-F (OZOFLEX Plus)
Cable length exceeding 10 m on request

(1) = n°. câbles x (n°. conducteurs câble x section [mm²]) x longueur câble [m] - Câble H07RN-F (OZOFLEX Plus)
Sur demande longueur de câble supérieure à 10 m

(1) = n°. cavi x (n°. conduttori per cavo x sezione [mm²]) x lunghezza cavo [m] - Cavo H07RN-F (OZOFLEX Plus)
Lunghezza cavo superiore a 10 m - su richiesta

Electric pump type <i>Electropompe type</i> Elettropompa tipo	Curve <i>Courbe</i> Curva	Motor power <i>Puiss. moteur</i> Potenza motore	Capacity <i>Debit</i> Portata															
			[l/s]	0	45	50	60	70	80	90	100	125	150	175	200	225	245	
(2)	(N°)	[kW]	Head <i>Hauteur</i> Prevalenza															
KCM250ZD+018582X1	1	18,5	NPSH _R															
			[m]															
				2	2	2	2	2	2	2	2	2,1	2,3	2,9	4	6,6	11,8	

P₂ = Power rated by the motor

Performance tolerance as per:
UNI/ISO 9906 Grade 3B

For models in the ATEX II 2G Ex db h IIB T4 Gb and I M2 Ex db h I Mb

For motor performances specification see page "motor features"

For the accessories specification see page "Accessories"

P₂ = Puissance restituée par le moteur

Tolérances sur les performances selon normes:
UNI/ISO 9906 Niveau 3B

Pour les modèles version antideflagrante ATEX II 2G Ex db h IIB T4 Gb et I M2 Ex db h I Mb

Pour caractéristiques techniques moteurs voir page "Caractéristiques des moteurs"

Pour les accessoires voir page "Accessories"

P₂ = Potenza resa dal motore

Tolleranze sulle prestazioni secondo norme:
UNI/ISO 9906 Grado 3B

Versione antideflagrante ATEX II 2G Ex db h IIB T4 Gb e I M2 Ex db h I Mb

Per caratteristiche motori vedere pagina "caratteristiche motori"

Per accessori vedere pagina accessori

(X)

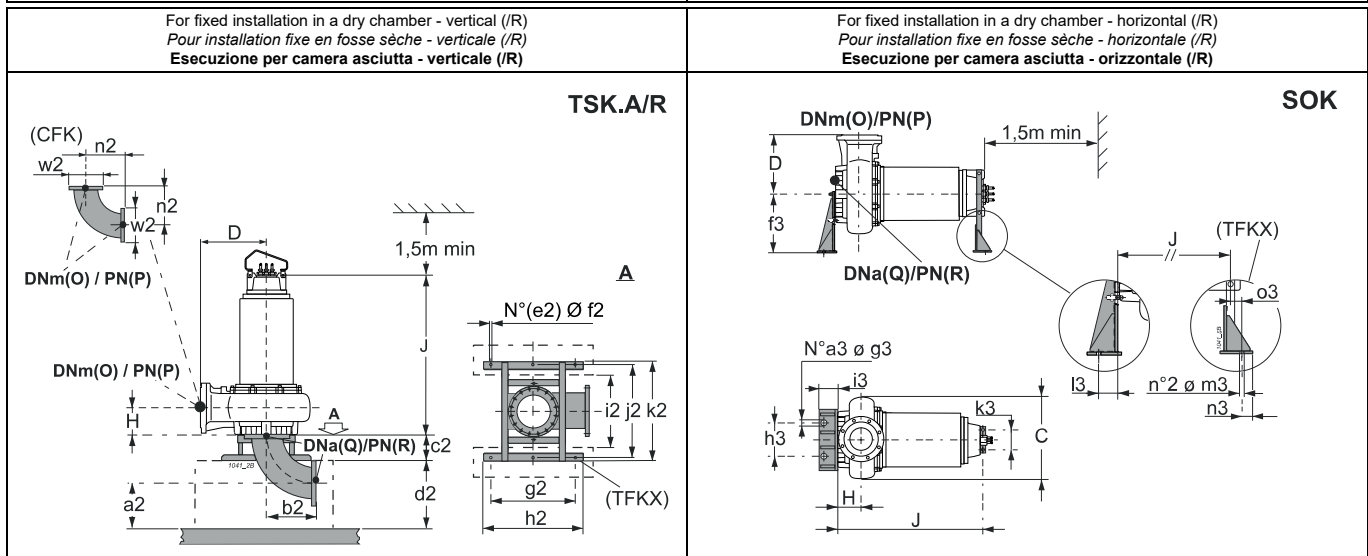
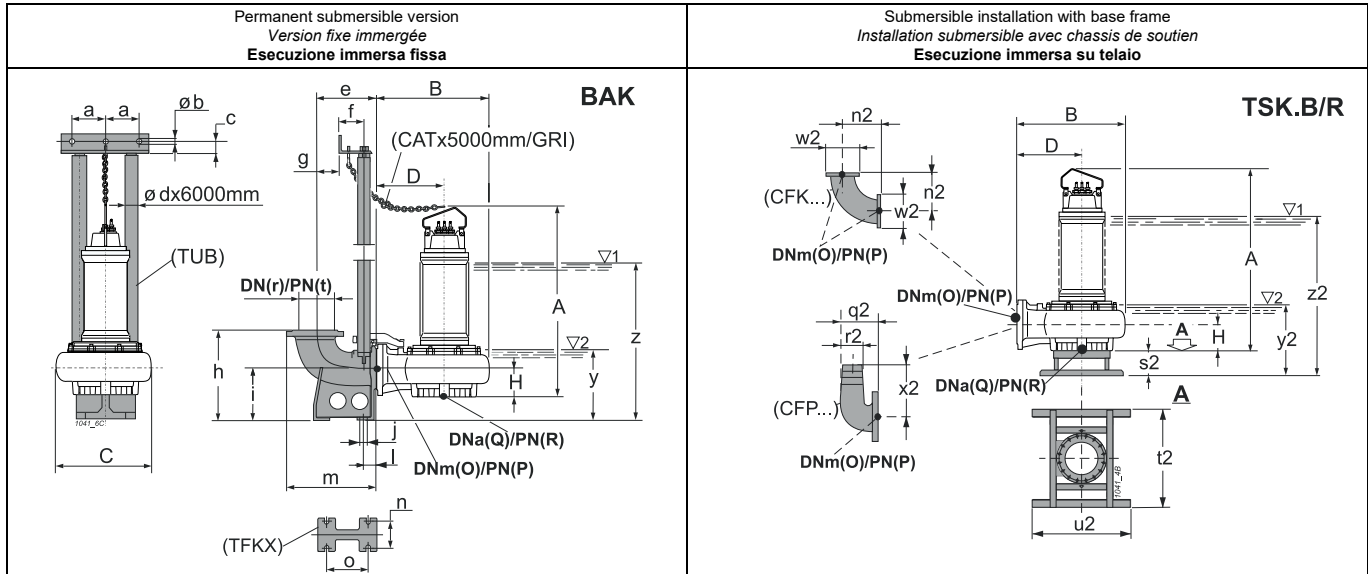

Type Type Tipo	Free passage Passage libre Passaggio Libero	Weight Poids Peso	A	B	C	D	H	J	O	P	Q	R	Accessories Accessoires Accessori					
			[mm]										BAK.	SOK.	TSK.A/R	TSK.B/R		
KCM250ZD+018582X1	Ø 163	653	1612,5	935	735	570	220	-	250	10	250	10	300/250 3"	-	-	350		
KCM250ZD+018582X1/R	Ø 163	668	1612,5	935	735	570	220	1335	250	10	250	10	300/250 3"	350-200	250	-		
BAK.	a	b	c	d	e	f	g	h	i	j	l	m	n	o	r	t	y	z
BAK300/250 3"	157,5	12,5	35	3"	450	117	245	700	400	24	85	673	310	425	300	10	585	1330
SOK.	a3	f3	g3	h3	i3	k3	l3	m3	n3	o3								
SOK350-200	3	530	22	500	160	270	100	22	40	85								
TSK.A/R	a2	b2	c2	d2	e2	f2	g2	h2	i2	j2	k2	n2	w2					
TSK250A/R	295	385	280	400	6	22	850	1000	740	935	1000	385	395					
TSK.B/R	n2	q2	r2	s2	t2	u2	w2	x2	y2	z2								
TSK350B/R	385	525	250	280	1000	1000	395	575	685	1430								

(3) z = Minimum submergence depth for motor without casing with continuous duty S1 (NPSHR permitting)
y = Minimum submergence depth for motor without casing with intermittent duty S3 (NPSHR permitting)

(3) z = Immersion minimum pour moteur sans chemise en service continu S1 (compatible avec le NPSHR)
y = Immersion minimum pour moteur sans chemise en service intermittent S3 (compatible avec le NPSHR)

(3) z = Immersione minima per motore senza mantello in funzione continuo S1 compatibilmente con l'NPSHR
y = Immersione minima con motore senza mantello in funzione intermittente S3 compatibilmente con l'NPSHR

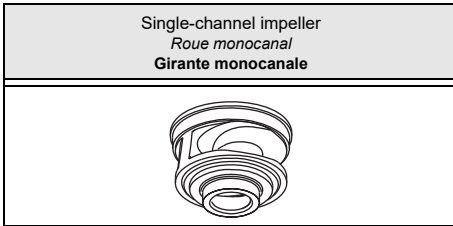

Type Type Tipo	KCM250R...+...62X1	
Thermal probes Sondes thermiques Sonde termiche	Yes Oui SI	
Conductivity probe Sonde de conductivité Sonda di conduttività	Yes Oui SI	

Version cable (1) Version câble (1) Cavo Versione (1)		
Electric pump type Electropompe type Elettropompa tipo	Power supply Alimentation Alimentazione	Auxiliary Auxiliaire Ausiliario
KCM250RM+022062X1	2x(4x10)x10	1x(5x1,5)x10
KCM250RH+030062X1	2x(4x10)x10	1x(5x1,5)x10
KCM250RE+037062X1	2x(4x16)x10	1x(5x1,5)x10
KCM250RB+045062X1	2x(4x16)x10	1x(5x1,5)x10

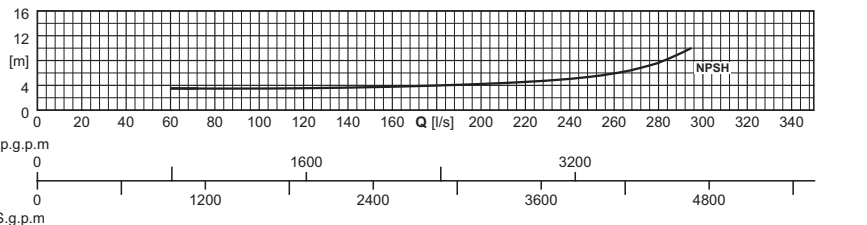
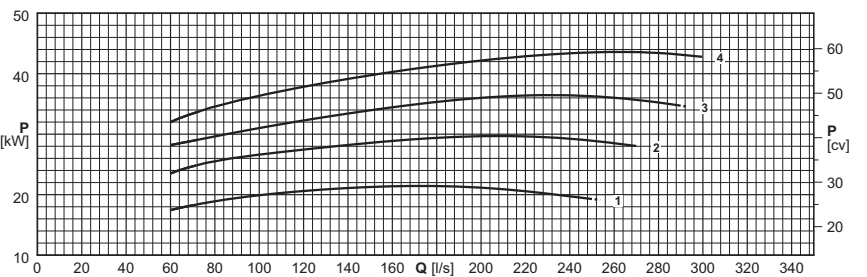
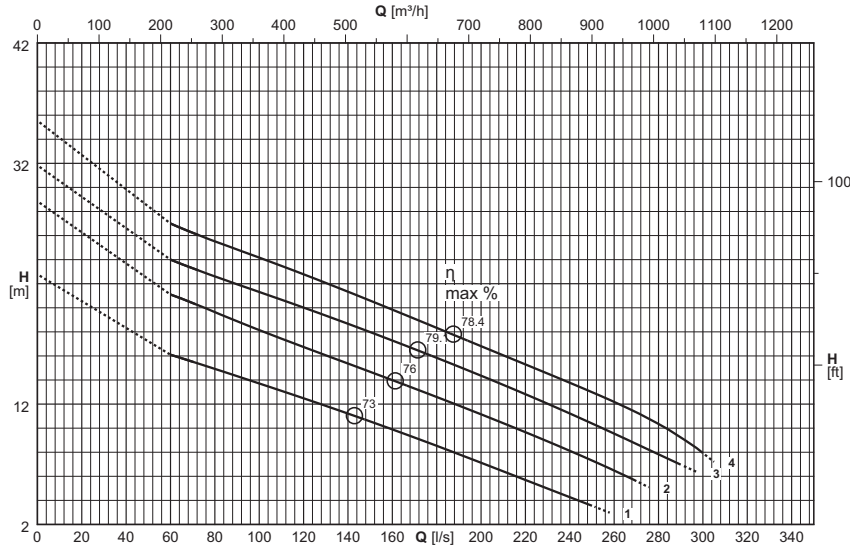

(1) = n°. of cables x (n°. of wires each cable x size [mm²]) x cable length [m] - Câble H07RN-F (OZOFLEX Plus)
Cable length exceeding 10 m on request

(1) = n°. câbles x (n°. conducteurs câble x section [mm²]) x longueur câble [m] - Câble H07RN-F (OZOFLEX Plus)
Sur demande longueur de câble supérieure à 10 m

(1) = n°. cavi x (n°. conduttori per cavo x sezione [mm²]) x lunghezza cavo [m] - Cavo H07RN-F (OZOFLEX Plus)
Lunghezza cavo superiore a 10 m - su richiesta

Electric pump type Electropompe type Elettropompa tipo	Curve Courbe Curva	Motor power Puiss. moteur Potenza motore	Capacity Débit Portata															
			[l/s]	0	70	80	90	100	125	150	175	200	225	250	275	300	305	
(2)	(N°)	[kW]	[m³/h]	0	252	288	324	360	450	540	630	720	810	900	990	1080	1098	
			Head Hauteur Prevalenza															
			[m]	20,8	15,5	14,9	14,3	13,7	12,2	10,6	8,9	7,1	5,3	3,6				
KCM250RM+022062X1	1	22	[m]	20,8	15,5	14,9	14,3	13,7	12,2	10,6	8,9	7,1	5,3	3,6				
KCM250RH+030062X1	2	30	[m]	26,9	20,4	19,6	18,9	18,2	16,4	14,7	12,9	11,1	9,3	7,3	5,1			
KCM250RE+037062X1	3	37	[m]	29,8	23,3	22,6	22	21,3	19,7	18	16,2	14,4	12,4	10,4	8,3			
KCM250RB+045062X1	4	45	[m]	33,5	26,2	25,5	24,8	24,2	22,4	20,6	18,7	16,8	14,9	13	10,8	7,9	7,2	
NPSH _R			[m]		3,5	3,5	3,5	3,5	3,5	3,7	3,9	4,2	4,7	5,4	7,1	11,7	13	

P₂ = Power rated by the motor
Performance tolerance as per:
UNI/ISO 9906 Grade 3B
For models in the ATEX II 2G Ex db h IIB T4 Gb and I M2 Ex db h I Mb
For motor performances specification see page "motor features"
For the accessories specification see page "Accessories"

P₂ = Puissance restituée par le moteur
Tolérances sur les performances selon normes:
UNI/ISO 9906 Niveau 3B
Pour les modèles version antidéflagrante ATEX II 2G Ex db h IIB T4 Gb et I M2 Ex db h I Mb
Pour caractéristiques techniques moteurs voir page "Caractéristiques des moteurs"
Pour les accessoires voir page "Accessories"

P₂ = Potenza resa dal motore
Tolleranze sulle prestazioni secondo norme:
UNI/ISO 9906 Grado 3B
Versione antidéflagrante ATEX II 2G Ex db h IIB T4 Gb e I M2 Ex db h I Mb
Per caratteristiche motori vedere pagina "caratteristiche motori"
Per accessori vedere pagina accessori

(X)

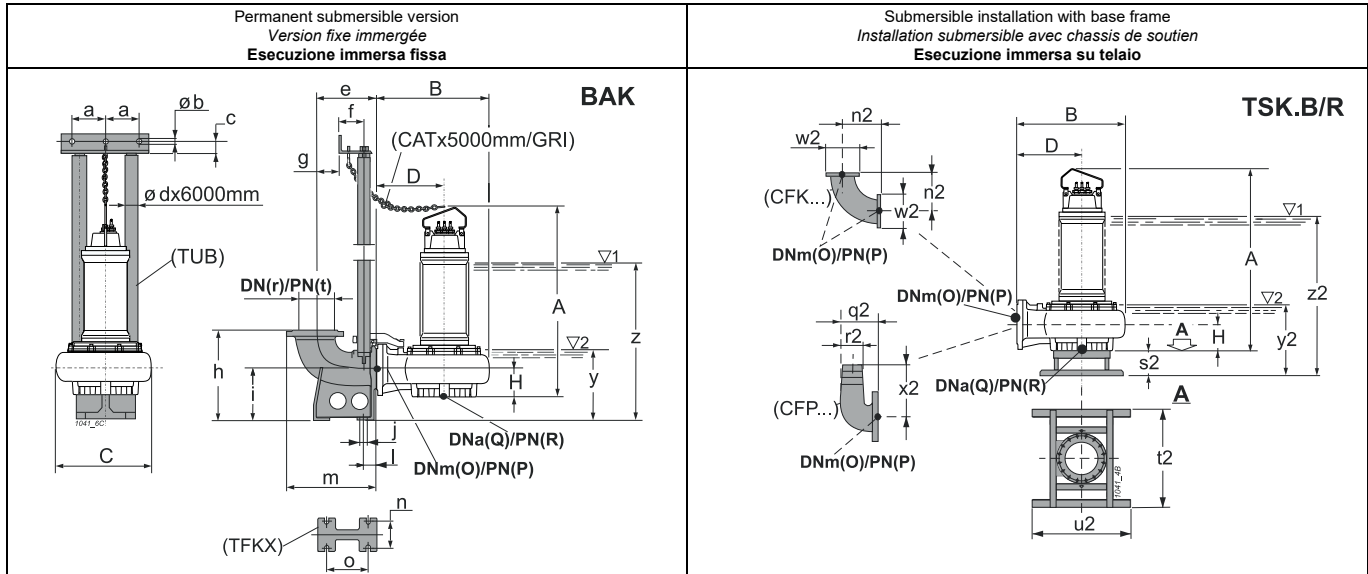

Permanent submersible version
Version fixe immergée
Esecuzione immersa fissa

Submersible installation with base frame
Installation submersible avec chassis de soutien
Esecuzione immersa su telaio

For fixed installation in a dry chamber - vertical (R)
Pour installation fixe en fosse sèche - verticale (R)
Esecuzione per camera asciutta - verticale (R)

For fixed installation in a dry chamber - horizontal (R)
Pour installation fixe en fosse sèche - horizontale (R)
Esecuzione per camera asciutta - orizzontale (R)

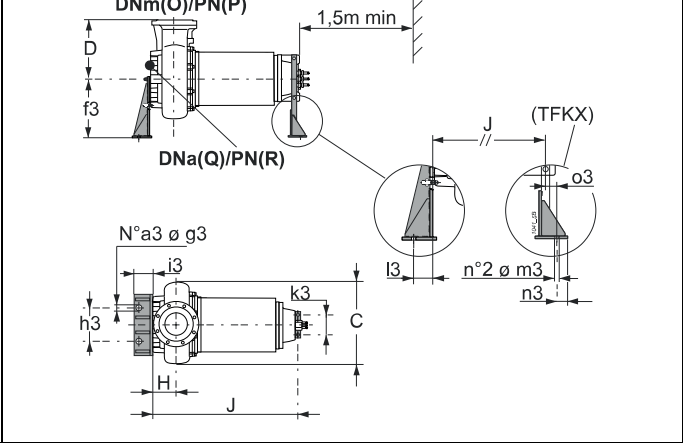
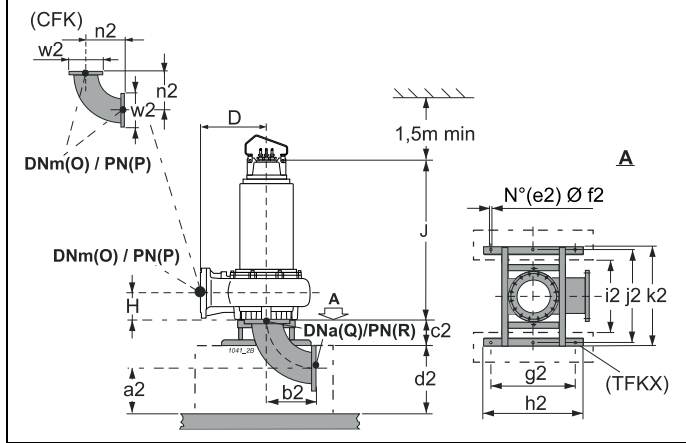

Type Type Tipo	Free passage Passage libre Passaggio Libero	Weight Poids Peso	[mm]											Accessories Accessoires Accessori			
			A	B	C	D	H	J	O	P	Q	R	BAK.	SOK.	TSK.A/R	TSK.B/R	
KCM250RM+022062X1	Ø 163	633	1612,5	935	735	570	220	-	250	10	250	10	300/250 3"	-	-	350	
KCM250RM+022062X1/R	Ø 163	648	1612,5	935	735	570	220	1335	250	10	250	10	300/250 3"	350-200	250	-	
KCM250RH+030062X1	Ø 163	653	1612,5	935	735	570	220	-	250	10	250	10	300/250 3"	-	-	350	
KCM250RH+030062X1/R	Ø 163	678	1612,5	935	735	570	220	1335	250	10	250	10	300/250 3"	350-200	250	-	
KCM250RE+037062X1	Ø 163	873	1634,5	935	735	570	220	-	250	10	250	10	300/250 3"	-	-	350	
KCM250RE+037062X1/R	Ø 163	893	1634,5	935	735	570	220	1347	250	10	250	10	300/250 3"	350-225	250	-	
KCM250RB+045062X1	Ø 163	1003	1644,5	935	735	570	220	-	250	10	250	10	300/250 3"	-	-	350	
KCM250RB+045062X1/R	Ø 163	1023	1644,5	935	735	570	220	1357	250	10	250	10	300/250 3"	350-250	250	-	

BAK.			a	b	c	d	e	f	g	h	i	j	l	m	n	o	r	t	y	z
BAK300/250 3"			157,5	12,5	35	3"	450	117	245	700	400	24	85	673	310	425	300	10	585	1330
SOK.			a3	f3	g3	h3	i3	k3	l3	m3	n3	o3								
SOK350-200			3	530	22	500	160	270	100	22	40	85								
SOK350-225			3	530	22	500	160	270	100	22	40	85								
SOK350-250			3	530	22	500	160	270	100	22	40	85								
TSK.A/R			a2	b2	c2	d2	e2	f2	g2	h2	i2	j2	k2	n2	w2 <td colspan="5"></td>					
TSK250A/R			295	385	280	400	6	22	850	1000	740	935	1000	385	395					
TSK.B/R			n2	q2	r2	s2	t2	u2	w2	x2	y2	z2 <td colspan="8"></td>								
TSK350B/R			385	525	250	280	1000	1000	395	575	685	1430								

(3) z = Minimum submergence depth for motor without casing with continuous duty S1 (NPSHR permitting)

(3) z = Immersion minimum pour moteur sans chemise en service continu S1 (compatible avec le NPSHR)

(3) z = Immersion minima per motore senza mantello in funzione continuo S1 compatibilmente con l'NPSHR

y = Minimum submergence depth for motor without casing with intermittent duty S3 (NPSHR permitting)

y = Immersion minimum pour moteur sans chemise en service intermittent S3 (compatible avec le NPSHR)

y = Immersion minima con motore senza mantello in funzione intermittente S3 compatibilmente con l'NPSHR

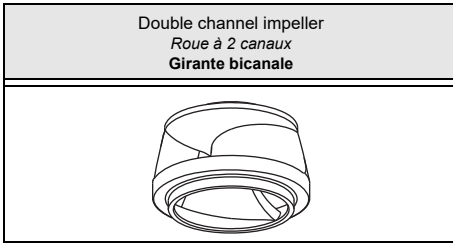

Type Type Tipo	KCD300Z...+...82X1	
Thermal probes Sondes thermiques Sonde termiche	Yes Oui SI	
Conductivity probe Sonde de conductivité Sonda di conduttività	Yes Oui SI	

Version cable (1)
Version câble (1)
Cavo Versione (1)

Electric pump type Electropompe type Elettropompa tipo	Power supply Alimentation Alimentazione	Auxiliary Auxiliaire Ausiliario
KCD300ZH+015082X1/R	2x(4x6)x10	1x(5x1,5)x10
KCD300ZG+015082X1	2x(4x6)x10	1x(5x1,5)x10
KCD300ZE+018582X1/R	2x(4x6)x10	1x(5x1,5)x10
KCD300ZD+018582X1	2x(4x6)x10	1x(5x1,5)x10

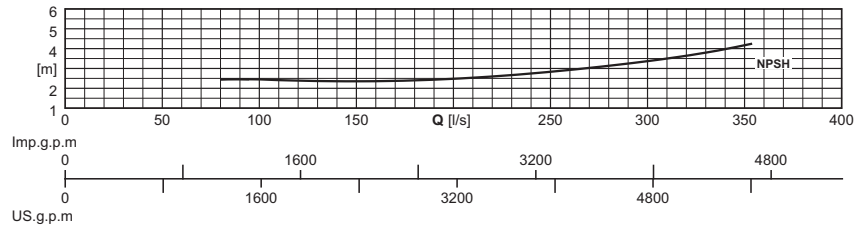
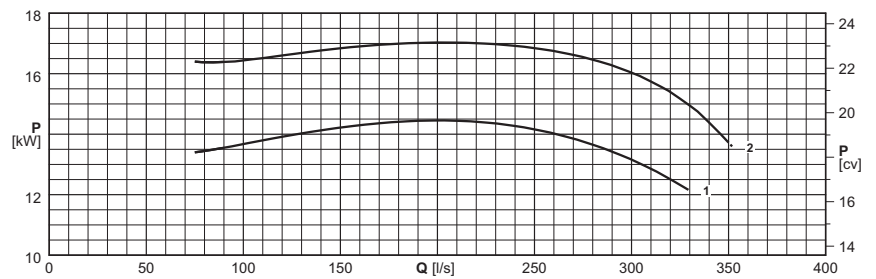
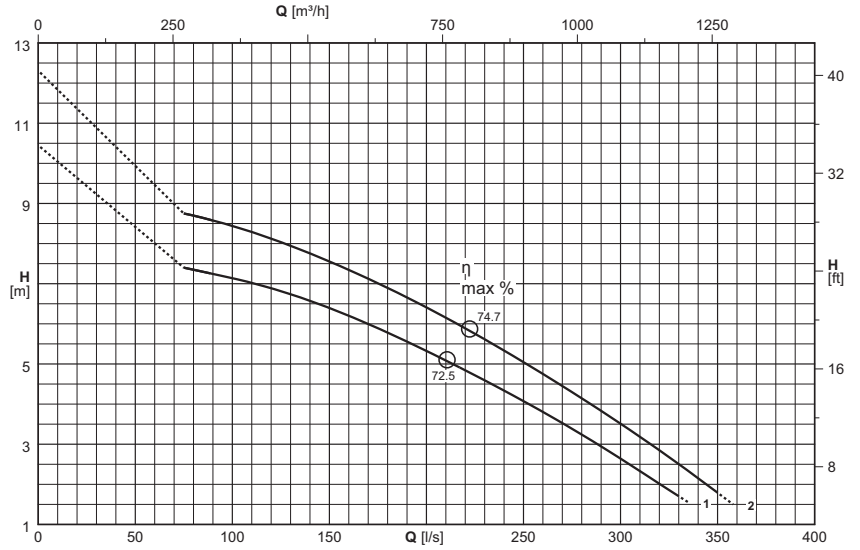

(1) = n°. of cables x (n°. of wires each cable x size [mm²]) x cable length [m] - Cable H07RN-F (OZOFLEX Plus)
Cable length exceeding 10 m on request

(1) = n°. câbles x (n°. conducteurs câble x section [mm²]) x longueur câble [m] - Câble H07RN-F (OZOFLEX Plus)
Sur demande longueur de câble supérieure à 10 m

(1) = n°. cavi x (n°. conduttori per cavo x sezione [mm²]) x lunghezza cavo [m] - Cavo H07RN-F (OZOFLEX Plus)
Lunghezza cavo superiore a 10 m - su richiesta

Electric pump type Electropompe type Elettropompa tipo	Curve Courbe Curva	Motor power Puiss. moteur Potenza motore	Capacity Débit Portata																
			[l/s]	0	80	90	100	125	150	175	200	225	250	275	300	325	350	358	
(2)	(N°)	[kW]	[m³/h]	0	288	324	360	450	540	630	720	810	900	990	1080	1170	1260	1288,8	
			Head Hauteur Prevalenza																
●KCD300ZH+015082X1/R	1	15	[m]	9,5	7,3	7,2	7,1	6,8	6,4	5,9	5,3	4,7	4,1	3,4	2,6	1,9			
○KCD300ZG+015082X1	1	15	[m]	9,5	7,3	7,2	7,1	6,8	6,4	5,9	5,3	4,7	4,1	3,4	2,6	1,9			
●KCD300ZE+018582X1/R	2	18,5	[m]	11,3	8,7	8,6	8,4	8	7,6	7	6,4	5,8	5	4,3	3,5	2,7	1,8	1,5	
○KCD300ZD+018582X1	2	18,5	[m]	11,3	8,7	8,6	8,4	8	7,6	7	6,4	5,8	5	4,3	3,5	2,7	1,8	1,5	
NPSH _R			[m]		2,4	2,5	2,4	2,4	2,4	2,4	2,5	2,6	2,8	3,1	3,4	3,7	4,2	4,4	

● Fixed installation in a dry chamber (R)
○ Submersible version
P₂ = Power rated by the motor
Performance tolerance as per:
UNI/ISO 9906 Grade 3B

For models in the ATEX II 2G Ex db h IIB T4 Gb and I M2 Ex db h I Mb
For motor performances specification see page "motor features"

For the accessories specification see page "Accessories"
The impellers will be trimmed to meet the duty point

● Installation fixe en fosse sèche (R)
○ Version immergée
P₂ = Puissance restituée par le moteur
Tolérances sur les performances selon normes:
UNI/ISO 9906 Niveau 3B

Pour les modèles version antidéflagrante ATEX II 2G Ex db h IIB T4 Gb et I M2 Ex db h I Mb
Pour caractéristiques techniques moteurs voir page "Caractéristiques des moteurs"

Pour les accessoires voir page "Accessories"
Le point de fonctionnement désiré peut être obtenu par rognage de roue

● Esecuzione per camera asciutta (R)
○ Esecuzione Immersa
P₂ = Potenza resa dal motore
Tolleranze sulle prestazioni secondo norme:
UNI/ISO 9906 Grado 3B

Versione antideflagrante ATEX II 2G Ex db h IIB T4 Gb e I M2 Ex db h I Mb
Per caratteristiche motori vedere pagina "caratteristiche motori"

Per accessori vedere pagina accessori
Le giranti vengono tornite in modo da ottenere il punto di lavoro richiesto

(X)

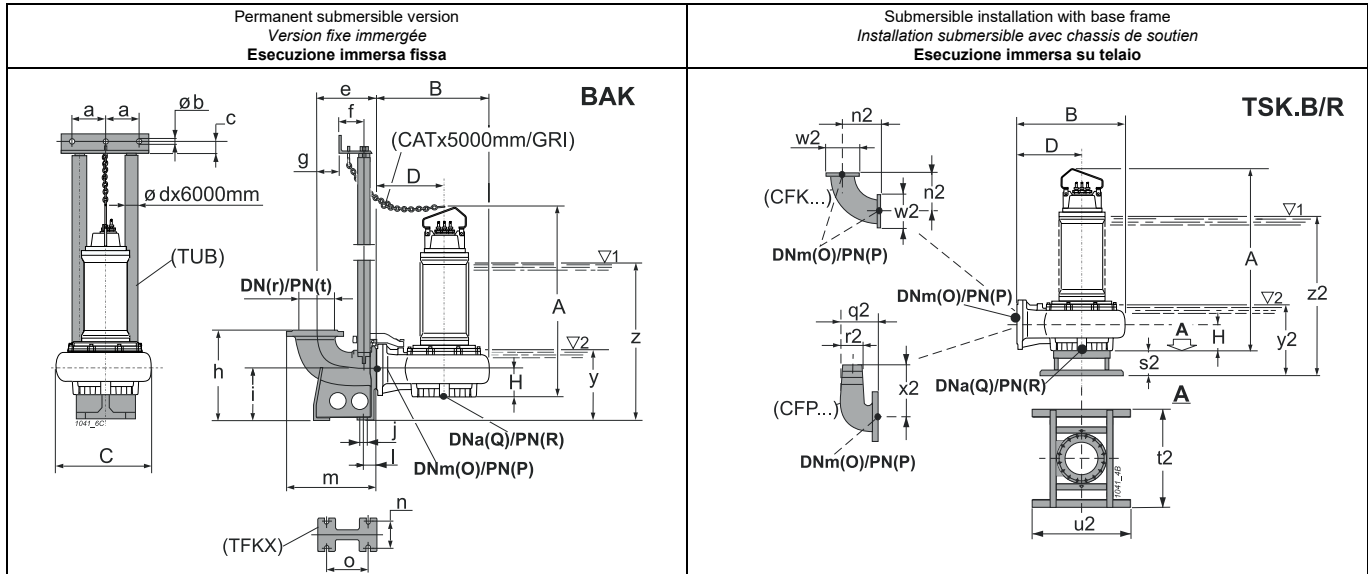

Permanent submersible version
Version fixe immergée
Esecuzione immersa fissa

Submersible installation with base frame
Installation submersible avec chassis de soutien
Esecuzione immersa su telaio

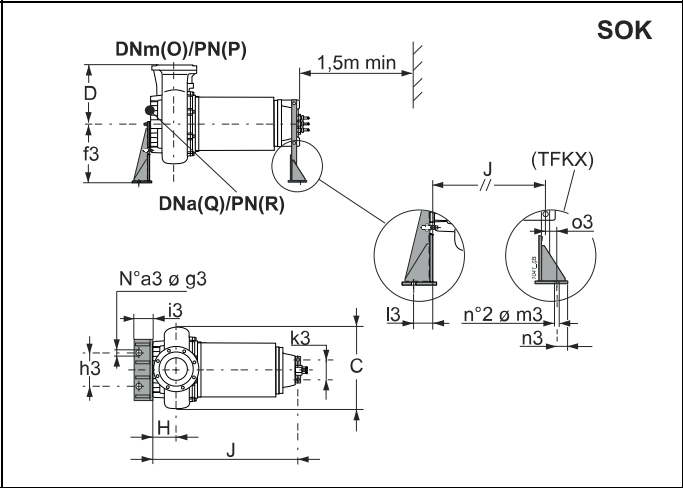
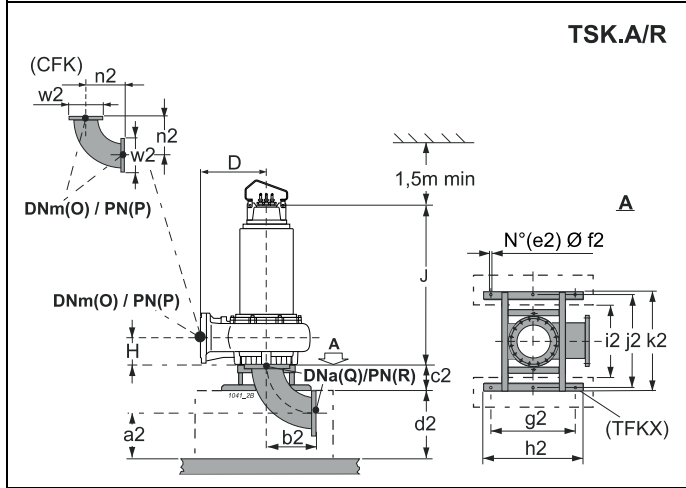

Type Type Tipo	Free passage Passage libre Passaggio Libero	Weight Poids Peso	A	B	C	D	H	J	O	P	Q	R	Accessories Accessoires Accessori			
			[mm]										BAK.	SOK.	TSK.A/R	TSK.B/R
●KCD300ZH+015082X1/R	Ø 143	691	1599,5	1030	820	620	230	1322	300	10	300	10	350/300 3"	350-200	300	-
○KCD300ZG+015082X1	Ø 143	676	1599,5	1030	820	620	230	-	300	10	300	10	350/300 3"	-	-	350
●KCD300ZE+018582X1/R	Ø 143	691	1599,5	1030	820	620	230	1322	300	10	300	10	350/300 3"	350-200	300	-
○KCD300ZD+018582X1	Ø 143	676	1599,5	1030	820	620	230	-	300	10	300	10	350/300 3"	-	-	350

BAK.	a	b	c	d	e	f	g	h	i	j	l	m	n	o	r	t	y	z
BAK350/300 3"	157,5	12,5	35	3"	500	117	295	820	500	24	90	755	360	475	350	10	665	1410
SOK.	a3	f3	g3	h3	i3	k3	l3	m3	n3	o3								
SOK350-200	3	530	22	500	160	270	100	22	40	85								
TSK.A/R	a2	b2	c2	d2	e2	f2	g2	h2	i2	j2	k2	n2	w2					
TSK300A/R	320	465	280	500	6	22	850	1000	740	935	1000	465	445					
TSK.B/R	n2	s2	t2	u2	w2	y2	z2											
TSK350B/R	465	280	1000	1000	445	675	1420											

(3) z = Minimum submergence depth for motor without casing with continuous duty S1 (NPSHR permitting)

(3) z = Immersion minimum pour moteur sans chemise en service continu S1 (compatible avec le NPSHR)

(3) z = Immersion minima per motore senza mantello in funzione continuo S1 compatibilmente con l'NPSHR

y = Minimum submergence depth for motor without casing with intermittent duty S3 (NPSHR permitting)

y = Immersion minimum pour moteur sans chemise en service intermittent S3 (compatible avec le NPSHR)

y = Immersion minima con motore senza mantello in funzione intermittente S3 compatibilmente con l'NPSHR

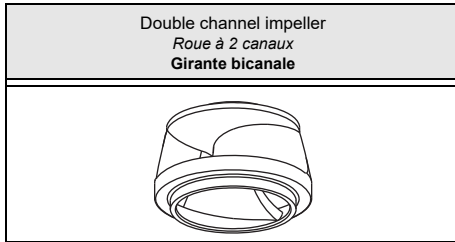

Type Type Tipo	KCD300R...62X1	
Thermal probes Sondes termiques Sonde termiche	Yes Oui SI	
Conductivity probe Sonde de conductivité Sonda di conduttività	Yes Oui SI	

Version cable (1) Version câble (1) Cavo Versione (1)		
Electric pump type Electropompe type Elettropompa tipo	Power supply Alimentation Alimentazione	Auxiliary Auxiliaire Ausiliario
KCD300RQ+022062X1/R	2x(4x10)x10	1x(5x1,5)x10
KCD300RP+022062X1	2x(4x10)x10	1x(5x1,5)x10
KCD300RL+030062X1/R	2x(4x10)x10	1x(5x1,5)x10
KCD300RI+030062X1	2x(4x10)x10	1x(5x1,5)x10
KCD300RH+037062X1/R	2x(4x16)x10	1x(5x1,5)x10
KCD300RG+037062X1	2x(4x16)x10	1x(5x1,5)x10
KCD300RE+045062X1/R	2x(4x16)x10	1x(5x1,5)x10
KCD300RD+045062X1	2x(4x16)x10	1x(5x1,5)x10

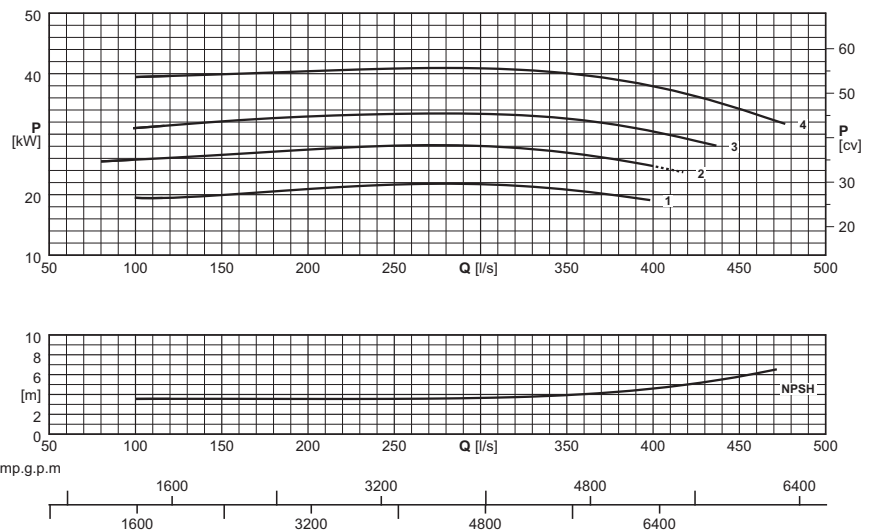
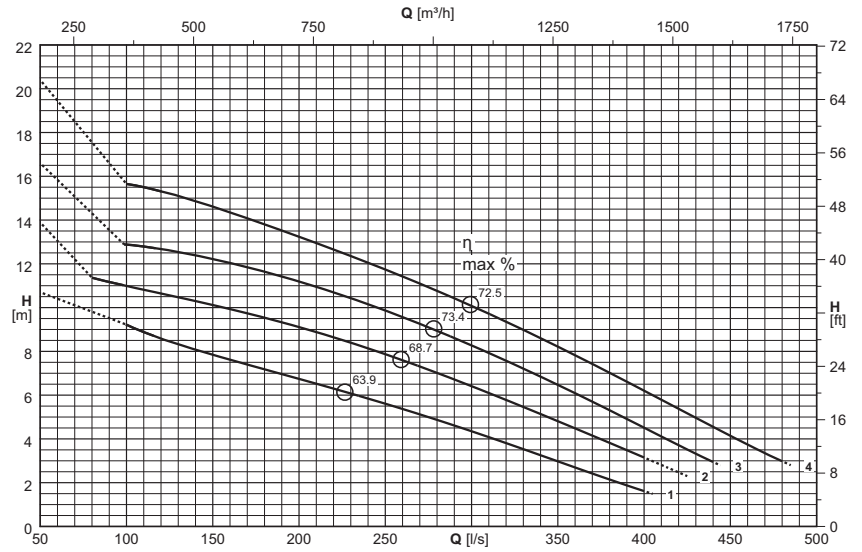

(1) = n°. of cables x (n°. of wires each cable x size [mm²]) x cable length [m] - Câble H07RN-F (OZOFLEX Plus)

Cable length exceeding 10 m on request

(1) = n°. câbles x (n°. conducteurs câble x section [mm²]) x longueur câble [m] - Câble H07RN-F (OZOFLEX Plus)

Sur demande longueur de câble supérieure à 10 m

(1) = n°. cavi x (n°. conduttori per cavo x sezione [mm²]) x lunghezza cavo [m] - Cavo H07RN-F (OZOFLEX Plus)

Lunghezza cavo superiore a 10 m - su richiesta

Electric pump type Electropompe type Elettropompa tipo	Curve Courbe Curva	Motor power Puiss. moteur Potenza motore	Capacity Débit Portata															
			[l/s]	0	90	100	125	150	175	200	250	300	350	400	450	485		
(2)	(N°)	[kW]	[m³/h]	0	324	360	450	540	630	720	900	1080	1260	1440	1620	1746		
			Head Hauteur Prevalenza															
			[m]	10,7	9,2	8,5	7,8	7,3	6,7	5,6	4,3	3	1,6					
●KCD300RQ+022062X1/R	1	22	[m]	10,7		9,2	8,5	7,8	7,3	6,7	5,6	4,3	3	1,6				
○KCD300RP+022062X1	1	22	[m]	10,7		9,2	8,5	7,8	7,3	6,7	5,6	4,3	3	1,6				
●KCD300RL+030062X1/R	2	30	[m]	13,9	11,2	11	10,6	10,1	9,6	9,1	7,9	6,4	4,8	3,1				
○KCD300RI+030062X1	2	30	[m]	13,9	11,2	11	10,6	10,1	9,6	9,1	7,9	6,4	4,8	3,1				
●KCD300RH+037062X1/R	3	37	[m]	16,6		12,9	12,6	12,2	11,7	11,2	9,9	8,3	6,5	4,5				
○KCD300RG+037062X1	3	37	[m]	16,6		12,9	12,6	12,2	11,7	11,2	9,9	8,3	6,5	4,5				
●KCD300RE+045062X1/R	4	45	[m]	20,4		15,7	15,2	14,6	13,9	13,2	11,7	10,1	8,2	6,2	4,1	2,8		
○KCD300RD+045062X1	4	45	[m]	20,4		15,7	15,2	14,6	13,9	13,2	11,7	10,1	8,2	6,2	4,1	2,8		
NPSH _R			[m]			3,6	3,6	3,6	3,6	3,5	3,6	3,7	3,9	4,6	5,8	7,1		

● Fixed installation in a dry chamber (I/R)

○ Submersible version

P₂ = Power rated by the motor

Performance tolerance as per:
UNI/ISO 9906 Grade 3B

For models in the ATEX II 2G Ex db h IIB T4 Gb and I M2 Ex db h I Mb

For motor performances specification see page "motor features"

For the accessories specification see page "Accessories"

The impellers will be trimmed to meet the duty point

● Installation fixe en fosse sèche (I/R)

○ Version immergée

P₂ = Puissance restituée par le moteur

Tolérances sur les performances selon normes:
UNI/ISO 9906 Niveau 3B

Pour les modèles version antidéflagrante ATEX II 2G Ex db h IIB T4 Gb et I M2 Ex db h I Mb

Pour caractéristiques techniques moteurs voir page "Caractéristiques des moteurs"

Pour les accessoires voir page "Accessories"

Le point de fonctionnement désiré peut être obtenu par rognage de roue

● Esecuzione per camera asciutta (I/R)

○ Esecuzione Immersa

P₂ = Potenza resa dal motore

Tolleranze sulle prestazioni secondo norme:
UNI/ISO 9906 Grado 3B

Versione antidéflagrante ATEX II 2G Ex db h IIB T4 Gb e I M2 Ex db h I Mb

Per caratteristiche motori vedere pagina "caratteristiche motori"

Per accessori vedere pagina accessori

Le giranti vengono tornite in modo da ottenere il punto di lavoro richiesto

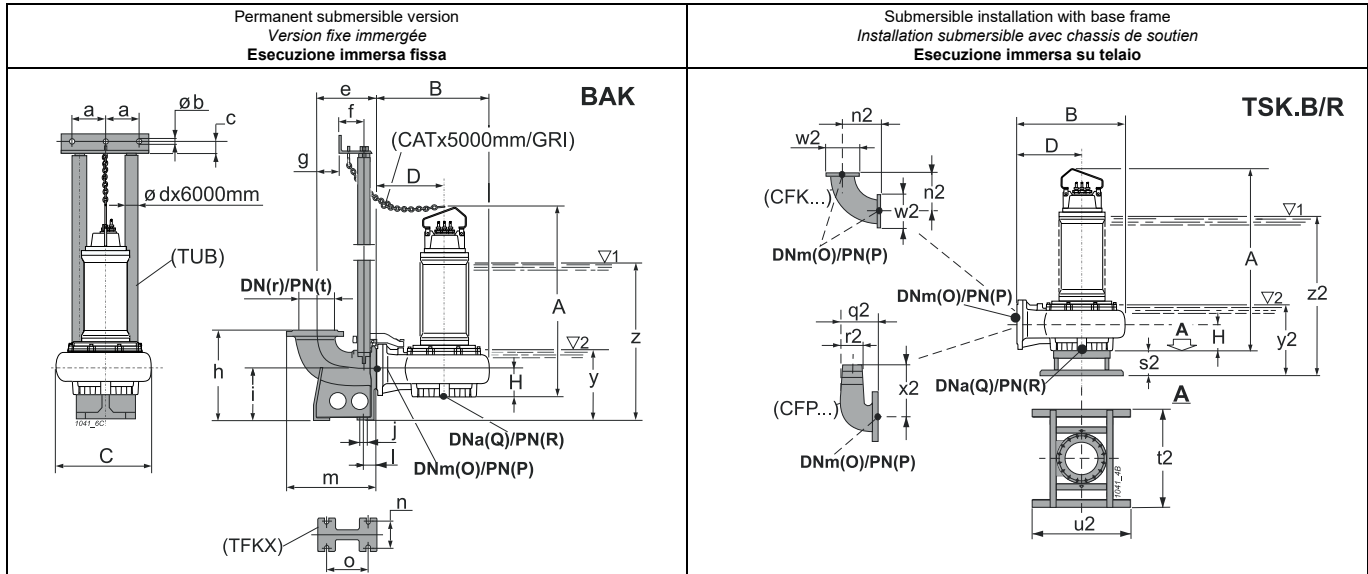

Permanent submersible version
Version fixe immergée
Esecuzione immersa fissa

Submersible installation with base frame
Installation submersible avec chassis de soutien
Esecuzione immersa su telaio

For fixed installation in a dry chamber - vertical (R)
Pour installation fixe en fosse sèche - verticale (R)
Esecuzione per camera asciutta - verticale (R)

For fixed installation in a dry chamber - horizontal (R)
Pour installation fixe en fosse sèche - horizontale (R)
Esecuzione per camera asciutta - orizzontale (R)

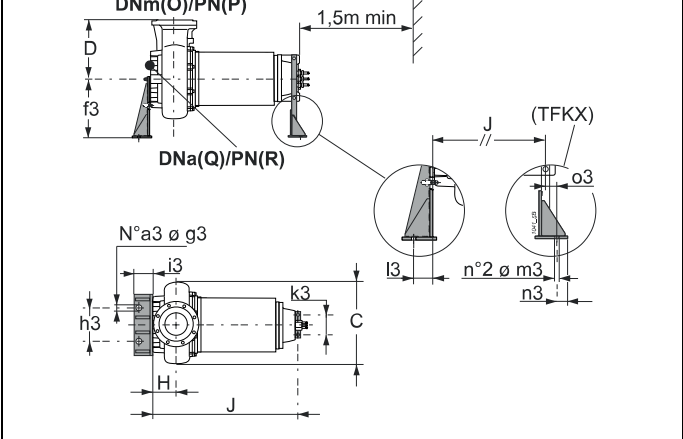
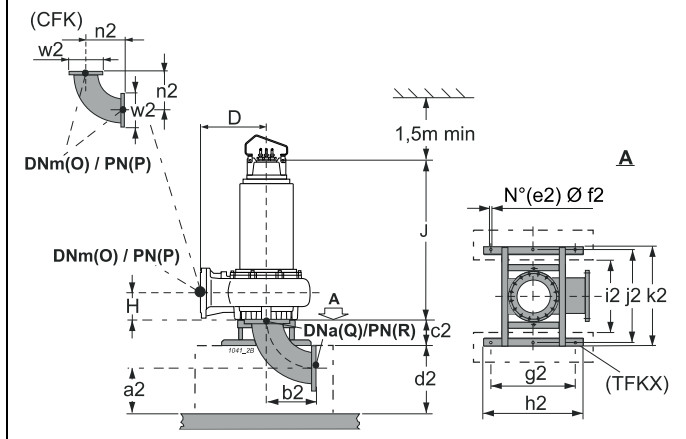

Type Type Tipo	Free passage Passage libre Passaggio Libero	Weight Poids Peso	[mm]												Accessories Accessoires Accessori			
			A	B	C	D	H	J	O	P	Q	R	BAK.	SOK.	TSK.A/R	TSK.B/R		
●KCD300RQ+022062X1/R	Ø 143	671	1599,5	1030	820	620	230	1322	300	10	300	10	350/300 3"	350-200	300	-		
○KCD300RP+022062X1	Ø 143	656	1599,5	1030	820	620	230	-	300	10	300	10	350/300 3"	-	-	350		
●KCD300RL+030062X1/R	Ø 143	691	1599,5	1030	820	620	230	1322	300	10	300	10	350/300 3"	350-200	300	-		
○KCD300RI+030062X1	Ø 143	676	1599,5	1030	820	620	230	-	300	10	300	10	350/300 3"	-	-	350		
●KCD300RH+037062X1/R	Ø 143	716	1621,5	1030	820	620	230	1334	300	10	300	10	350/300 3"	350-225	300	-		
○KCD300RG+037062X1	Ø 143	696	1621,5	1030	820	620	230	-	300	10	300	10	350/300 3"	-	-	350		
●KCD300RE+045062X1/R	Ø 143	1046	1631,5	1030	820	620	230	1344	300	10	300	10	350/300 3"	350-250	300	-		
○KCD300RD+045062X1	Ø 143	1026	1631,5	1030	820	620	230	-	300	10	300	10	350/300 3"	-	-	350		

BAK.	a	b	c	d	e	f	g	h	i	j	l	m	n	o	r	t	y	z
BAK350/300 3"	157,5	12,5	35	3"	500	117	295	820	500	24	90	755	360	475	350	10	665	1410
SOK.	a3	f3	g3	h3	i3	k3	l3	m3	n3	o3								
SOK350-200	3	530	22	500	160	270	100	22	40	85								
SOK350-225	3	530	22	500	160	270	100	22	40	85								
SOK350-250	3	530	22	500	160	270	100	22	40	85								
TSK.A/R	a2	b2	c2	d2	e2	f2	g2	h2	i2	j2	k2	n2	w2					
TSK300A/R	320	465	280	500	6	22	850	1000	740	935	1000	465	445					
TSK.B/R	n2	s2	t2	u2	w2	y2	z2											
TSK350B/R	465	280	1000	1000	445	675	1420											

(3) z = Minimum submergence depth for motor without casing with continuous duty S1 (NPSHR permitting)

(3) z = Immersion minimum pour moteur sans chemise en service continu S1 (compatible avec le NPSHR)

(3) z = Immersion minima per motore senza mantello in funzione continuo S1 compatibilmente con l'NPSHR

y = Minimum submergence depth for motor without casing with intermittent duty S3 (NPSHR permitting)

y = Immersion minimum pour moteur sans chemise en service intermittent S3 (compatible avec le NPSHR)

y = Immersion minima con motore senza mantello in funzione intermittente S3 compatibilmente con l'NPSHR

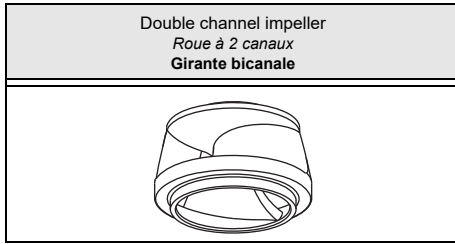

Type Type Tipo	KCD350R...82X1	
Thermal probes Sondes thermiques Sonde termiche	Yes Oui Sì	
Conductivity probe Sonde de conductivité Sonda di conduttività	Yes Oui Sì	

Version cable (1) Version câble (1) Cavo Versione (1)		
Electric pump type Electropompe type Elettropompa tipo	Power supply Alimentation Alimentazione	Auxiliary Auxiliaire Ausiliario
KCD350RW+018582X1/R	2x(4x6)x10	1x(5x1,5)x10
KCD350RV+018582X1	2x(4x6)x10	1x(5x1,5)x10
KCD350RS+022082X1/R	2x(4x10)x10	1x(5x1,5)x10
KCD350RR+022082X1	2x(4x10)x10	1x(5x1,5)x10
KCD350RM+030082X1/R	2x(4x10)x10	1x(5x1,5)x10
KCD350RL+030082X1	2x(4x10)x10	1x(5x1,5)x10
KCD350RE+037082X1/R	2x(4x10)x10	1x(5x1,5)x10
KCD350RD+037082X1	2x(4x10)x10	1x(5x1,5)x10

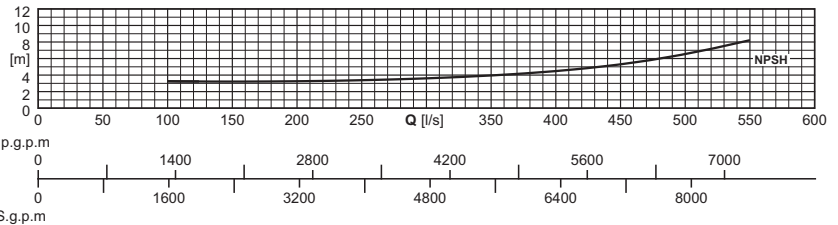
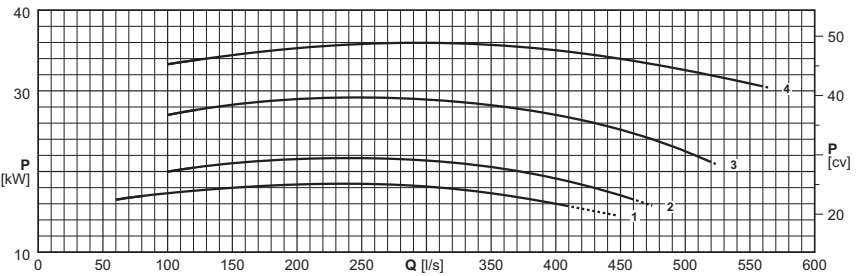
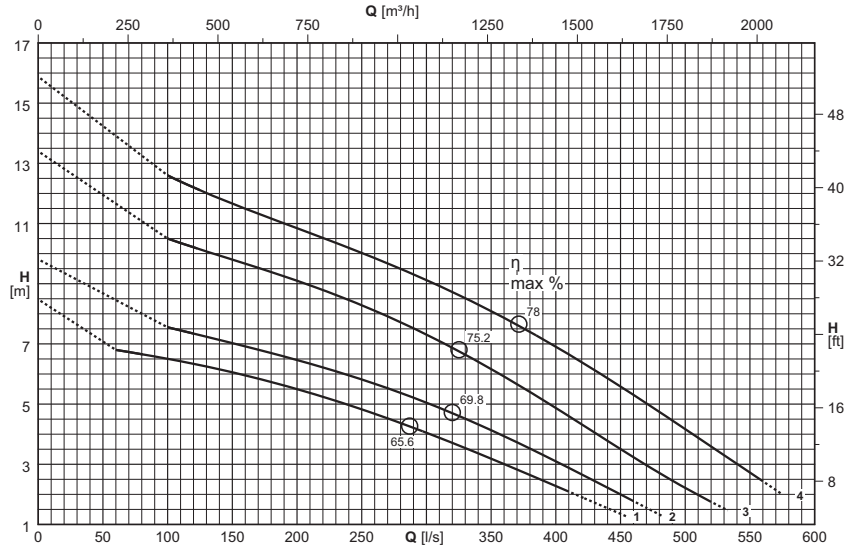

(1) = n°. of cables x (n°. of wires each cable x size [mm²]) x cable length [m] - Câble H07RN-F (OZOFLEX Plus)
Cable length exceeding 10 m on request

(1) = n°. câbles x (n°. conducteurs câble x section [mm²]) x longueur câble [m] - Câble H07RN-F (OZOFLEX Plus)
Sur demande longueur de câble supérieure à 10 m

(1) = n°. cavi x (n°. conduttori per cavo x sezione [mm²]) x lunghezza cavo [m] - Cavo H07RN-F (OZOFLEX Plus)
Lunghezza cavo superiore a 10 m - su richiesta

Electric pump type Electropompe type Elettropompa tipo	Curve Courbe Curva	Motor power Puiss. moteur Potenza motore	Capacity Débit Portata																	
			[l/s]	0	70	75	100	125	150	175	200	250	300	350	400	450	500	550	575	
(2)	(N°)	[kW]	[m³/h]	0	252	270	360	450	540	630	720	900	1080	1260	1440	1620	1800	1980	2070	
●KCD350RW+018582X1/R	1	18,5	[m]	7,5	6,7	6,7	6,5	6,3	6,1	5,8	5,5	4,8	4	3,2	2,3	1,4				
○KCD350RV+018582X1	1	18,5	[m]	7,5	6,7	6,7	6,5	6,3	6,1	5,8	5,5	4,8	4	3,2	2,3	1,4				
●KCD350RS+022082X1/R	2	22	[m]	8,8			7,6	7,3	7	6,8	6,5	5,8	5	4,1	3,1	2				
○KCD350RR+022082X1	2	22	[m]	8,8			7,6	7,3	7	6,8	6,5	5,8	5	4,1	3,1	2				
●KCD350RM+030082X1/R	3	30	[m]	12,4			10,5	10,1	9,8	9,5	9,1	8,3	7,3	6,2	4,9	3,5	2,2			
○KCD350RL+030082X1	3	30	[m]	12,4			10,5	10,1	9,8	9,5	9,1	8,3	7,3	6,2	4,9	3,5	2,2			
●KCD350RE+037082X1/R	4	37	[m]	14,9			12,6	12,1	11,7	11,2	10,8	10	9,1	8,1	6,9	5,6	4,2	2,7	2	
○KCD350RD+037082X1	4	37	[m]	14,9			12,6	12,1	11,7	11,2	10,8	10	9,1	8,1	6,9	5,6	4,2	2,7	2	
NPSH _R			[m]				3,3	3,2	3,2	3,2	3,3	3,4	3,6	4	4,5	5,3	6,5	8,2	9,2	

● Fixed installation in a dry chamber (I/R)

○ Submersible version

P₂ = Power rated by the motor

Performance tolerance as per:
UNI/ISO 9906 Grade 3B

For models in the ATEX II 2G Ex db h IIB T4 Gb and I M2 Ex db h I Mb

For motor performances specification see page "motor features"

For the accessories specification see page "Accessories"

The impellers will be trimmed to meet the duty point

● Installation fixe en fosse sèche (I/R)

○ Version immergée

P₂ = Puissance restituée par le moteur

Tolérances sur les performances selon normes:
UNI/ISO 9906 Niveau 3B

Pour les modèles version antidéflagrante ATEX II 2G Ex db h IIB T4 Gb et I M2 Ex db h I Mb

Pour caractéristiques techniques moteurs voir page "Caractéristiques des moteurs"

Pour les accessoires voir page "Accessories"

Le point de fonctionnement désiré peut être obtenu par rognage de roue

● Esecuzione per camera asciutta (I/R)

○ Esecuzione Immersa

P₂ = Potenza resa dal motore

Tolleranze sulle prestazioni secondo norme:
UNI/ISO 9906 Grado 3B

Versione antidéflagrante ATEX II 2G Ex db h IIB T4 Gb e I M2 Ex db h I Mb

Per caratteristiche motori vedere pagina "caratteristiche motori"

Per accessori vedere pagina accessori

Le giranti vengono tornite in modo da ottenere il punto di lavoro richiesto

(X)

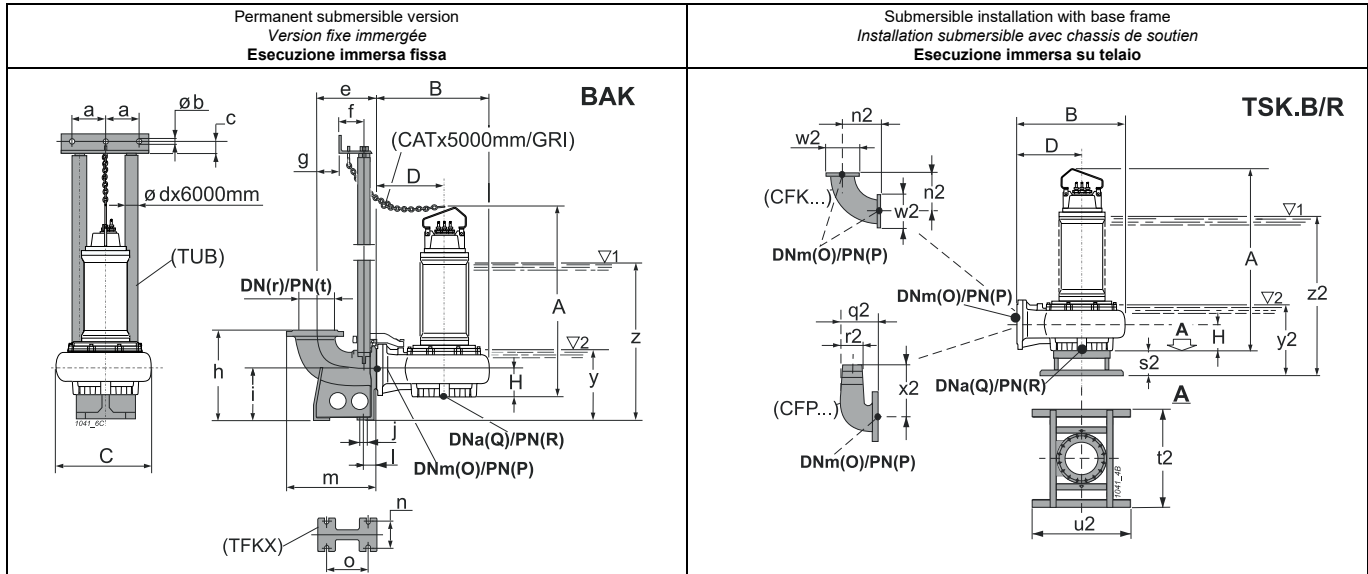

Permanent submersible version
Version fixe immergée
Esecuzione immersa fissa

Submersible installation with base frame
Installation submersible avec chassis de soutien
Esecuzione immersa su telaio

For fixed installation in a dry chamber - vertical (R)
Pour installation fixe en fosse sèche - verticale (R)
Esecuzione per camera asciutta - verticale (R)

For fixed installation in a dry chamber - horizontal (R)
Pour installation fixe en fosse sèche - horizontale (R)
Esecuzione per camera asciutta - orizzontale (R)

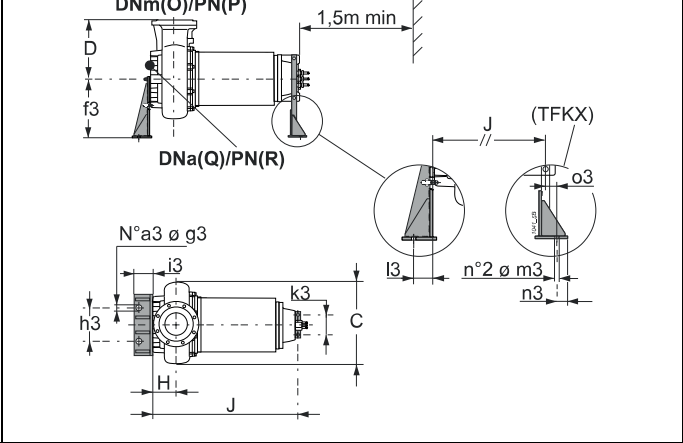
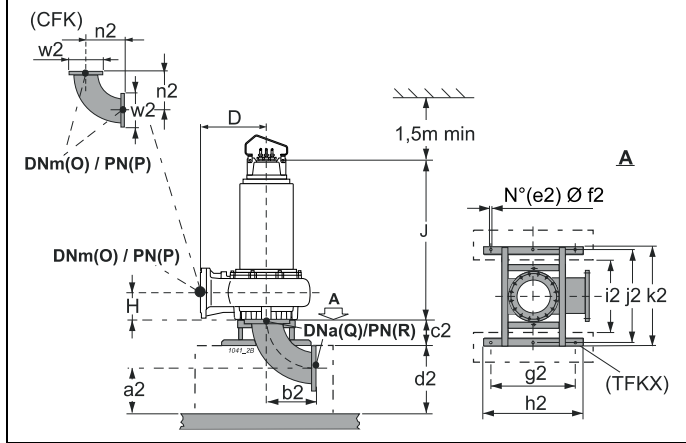

Type Type Tipo	Free passage Passage libre Passaggio Libero	Weight Poids Peso	A	B	C	D	H	J	O	P	Q	R	Accessories Accessoires Accessori			
			[mm]										BAK.	SOK.	TSK.A/R	TSK.B/R
●KCD350RW+018582X1/R	Ø 164	800	1640,5	1170	935	700	268	1363	350	10	350	10	400/350 3"	350-200	350	-
○KCD350RV+018582X1	Ø 164	785	1640,5	1170	935	700	268	-	350	10	350	10	400/350 3"	-	-	350
●KCD350RS+022082X1/R	Ø 164	990	1662,5	1170	935	700	268	1375	350	10	350	10	400/350 3"	350-225	350	-
○KCD350RR+022082X1	Ø 164	970	1662,5	1170	935	700	268	-	350	10	350	10	400/350 3"	-	-	350
●KCD350RM+030082X1/R	Ø 164	1025	1662,5	1170	935	700	268	1375	350	10	350	10	400/350 3"	350-225	350	-
○KCD350RL+030082X1	Ø 164	1005	1662,5	1170	935	700	268	-	350	10	350	10	400/350 3"	-	-	350
●KCD350RE+037082X1/R	Ø 164	1175	1672,5	1170	935	700	268	1385	350	10	350	10	400/350 3"	350-250	350	-
○KCD350RD+037082X1	Ø 164	1155	1672,5	1170	935	700	268	-	350	10	350	10	400/350 3"	-	-	350

BAK.	a	b	c	d	e	f	g	h	i	j	l	m	n	o	r	t	y	z
BAK400/350 3"	157,5	12,5	35	3"	525	117	320	920	575	24	95	810	400	510	400	10	767	1577
SOK.	a3	f3	g3	h3	i3	k3	l3	m3	n3	o3								
SOK350-200	3	530	22	500	160	270	100	22	40	85								
SOK350-225	3	530	22	500	160	270	100	22	40	85								
SOK350-250	3	530	22	500	160	270	100	22	40	85								
TSK.A/R	a2	b2	c2	d2	e2	f2	g2	h2	i2	j2	k2	n2	w2 <td colspan="5"></td>					
TSK350A/R	345	540	280	600	6	22	850	1000	740	935	1000	540	505					
TSK.B/R	n2	s2	t2	u2	w2	y2	z2 <td colspan="11"></td>											
TSK350B/R	540	280	1000	1000	505	740	1550											

(3) z = Minimum submergence depth for motor without casing with continuous duty S1 (NPSHR permitting)

(3) z = Immersion minimum pour moteur sans chemise en service continu S1 (compatible avec le NPSHR)

(3) z = Immersion minima per motore senza mantello in funzione continuo S1 compatibilmente con l'NPSHR

y = Minimum submergence depth for motor without casing with intermittent duty S3 (NPSHR permitting)

y = Immersion minimum pour moteur sans chemise en service intermittent S3 (compatible avec le NPSHR)

y = Immersion minima con motore senza mantello in funzione intermittente S3 compatibilmente con l'NPSHR

The following are also available: Anchoring bolts, level regulators and Electric panels

Accessoires supplémentaires: Tire-fond, Régulateurs de niveau et coffrets électriques

Sono inoltre disponibili: tirafondi, regolatori di livello e quadri elettrici

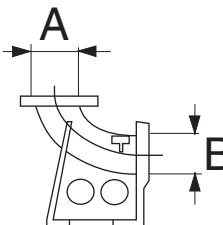
Duck-foot pedestal for automatic coupling (*) <i>Pied d'assise pour accouplement automatique (*)</i> Piede di accoppiamento automatico (*)	Type Type Tipo	A		B		Weight Poids Peso [Kg]	Electric pump type <i>Electropompe type</i> Elettropompa tipo					
		DN	UNI PN	DN	UNI PN		KCM150R	KCM250R	KCM250Z	KCD300R	KCD300Z	KCD350R
	BAK300/250 3"	300	10	250	10	160	-	•	•	-	-	-
	BAK350/300 3"	350	10	300	10	230	-	-	-	•	•	-
	BAK400/350 3"	400	10	350	10	310	-	-	-	-	-	•
	BAKM/I 3"	200	10	150	16	88	•	-	-	-	-	-

(*) = Complete with:

Pump coupling bracket (nodular cast iron)

Rail pipes anchor bracket (stainless steel)

Screw and nuts

(*) = Composé de:

Support de guidage (fonte à graphite sphéroïdale)

Support de barre de guidage (acier inox)

Visserie

(*) = Completo di:

Staffa corpo premente (ghisa sferoidale)

Staffa per tubi guida (acciaio inox)



Minuteria

Rail pipes (*) (dipped galvanized steel) <i>Barres de guidage (*) (acier galvanisé à chaud)</i> Tubi guida (*) (acciaio zincato a caldo)	Type Type Tipo	Weight Poids Peso [Kg]	Electric pump type <i>Electropompe type</i> Elettropompa tipo					
			KCM150R	KCM250R	KCM250Z	KCD300R	KCD300Z	KCD350R
	TUB 3"	51	•	•	•	•	•	•

(*) = On demand: stainless steel

(*) = Sur demande: acier inox

(*) = Su richiesta: acciaio inox

Chain and Shackle Kit (*) <i>Kit Chaîne et manille (*)</i> Kit Catena e Grillo (*)	Type Type Tipo	Max load Portée max Portata max [Kg]	Length Longueur Lunghezza [m]	Electric pump type <i>Electropompe type</i> Elettropompa tipo					
				KCM150R	KCM250R	KCM250Z	KCD300R	KCD300Z	KCD350R
CAT  GRI 	CAT D.14 / GRL D.16	2500	5	•	•	•	•	•	•
				•	•	•	•	•	•

(*) = On demand: stainless steel

(*) = Sur demande: acier inox

(*) = Su richiesta: acciaio inox

Base frame (dipped galvanized steel) <i>Chassis de soutien (acier galvanisé)</i> Telaio di sostegno (acciaio zincato a caldo)	Type Type Tipo	Weight Poids Peso [Kg]	Electric pump type <i>Electropompe type</i> Elettropompa tipo					
			KCM150R	KCM250R	KCM250Z	KCD300R	KCD300Z	KCD350R
	TSK150B/R	46	•	-	-	-	-	-
	TSK350B/R	53	-	•	•	•	•	•

Flanged hose connection (dipped galvanized steel) <i>Coude pour tuyauterie souple (acier galvanisé à chaud)</i> Curva flangiata portagomma (acciaio zincato a caldo)	Type Type Tipo	Weight Poids Peso [Kg]	Electric pump type <i>Electropompe type</i> Elettropompa tipo					
			KCM150R	KCM250R	KCM250Z	KCD300R	KCD300Z	KCD350R
	CFP150	18	•	-	-	-	-	-
	CFP250	51	-	•	•	-	-	-

Supports (Steel with protective paint) <i>Support de soutien (Acier revêtu de peinture de protection)</i> Supporti (acciaio con vernice protettiva)	Type Type Tipo	Weight Poids Peso [Kg]	Electric pump type <i>Electropompe type</i> Elettropompa tipo					
			KCM150R	KCM250R	KCM250Z	KCD300R	KCD300Z	KCD350R
	SOK150-200	67	30-37	-	-	-	-	-
	SOK150-225	70	45	-	-	-	-	-
	SOK150-250	67	55	-	-	-	-	-
	SOK350-200	73	-	22-30	18,5	22-30	15-18,5	18,5
	SOK350-225	73	-	37	-	37	-	22-30
	SOK350-250	73	-	45	-	45	-	37

Base frame (dipped galvanized steel) <i>Chassis de soutien (acier galvanisé)</i> Telaio di sostegno (acciaio zincato a caldo)	Type Type Tipo	A		B		Weight Poids Peso [Kg]	Electric pump type <i>Electropompe type</i> Elettropompa tipo					
		DN	UNI PN	DN	UNI PN		KCM150R	KCM250R	KCM250Z	KCD300R	KCD300Z	KCD350R
	TSK150A/R	150	16	150	16	80	●	-	-	-	-	-
	TSK250A/R	250	10	250	10	101	-	●	●	-	-	-
	TSK300A/R	300	10	300	10	116	-	-	-	●	●	-
	TSK350A/R	350	10	350	10	128	-	-	-	-	-	●

(*) = Fixed installation in a dry chamber

(*) = Installation fixe en fosse

(*) = Esecuzione per camera asciutta

Flanged elbow (dipped galvanized steel) <i>Coude bridé (acier galvanisé à chaud)</i> Curva flangiata (acciaio zincato a caldo)	Type Type Tipo	A		B		Weight Poids Peso [Kg]	Electric pump type <i>Electropompe type</i> Elettropompa tipo					
		DN	UNI PN	DN	UNI PN		KCM150R	KCM250R	KCM250Z	KCD300R	KCD300Z	KCD350R
	CFK150	150	16	150	16	25,5	●	-	-	-	-	-
	CFK250	250	10	250	10	43,5	-	●	●	-	-	-
	CFK300	300	10	300	10	62	-	-	-	●	●	-
	CFK350	350	10	350	10	87,5	-	-	-	-	-	●

50 Hz motor features (*X)
Caractéristiques des moteurs à 50 Hz (*X)
Caratteristiche motori a 50 Hz (*X)

Poles Pôles Poli	Motor type Moteur type Motore tipo	Motor power Puiss. moteur Potenza motore		Absorption Intensité Assorbimento	Direct starting Démarrage direct Avviamento diretto	Direct starting2 Démarrage direct2 Avviamento diretto2		Starts / hour max Max démarrages / heure Max avviamenti/ora	Degree of intermittence Degré d'intermittence Grado di intermittenza
		P ₁	P ₂	IN (400V)		(Standard)			
		[kW]		[A]		I _S /I _N	Direct Direct Diretto		
8	KC01508..Z200..	17	15	32,6	6,4	●	●	10	-
	KC01858..R200..	21,3	18,5	39,7	6,3	●	●	10	-
	KC01858..Z200..	21,3	18,5	39,7	6,3	●	●	10	-
	KC02208..R225..	25,9	22	53	5	●	●	10	-
	KC03008..R225..	35,3	30	72,6	4,9	●	●	10	-
	KC03708..R250..	42,5	37	80,3	4,6	●	●	10	-
6	KC02206..R200..	25,3	22	44,4	6,8	●	●	10	-
	KC03006..R200..	34,5	30	61,8	6,6	●	●	10	-
	KC03706..R225..	41,6	37	75,2	6,4	●	●	10	-
	KC04506..R250..	50	45	92	6,5	●	●	10	-
4	KC03004..R200..	34,5	30	56,7	7,3	●	●	10	-
	KC03704..R200..	42,5	37	71,7	7,2	●	●	10	-
	KC04504..R225..	49,5	45	84	6,8	●	●	10	-
	KC05504..R250..	59,8	55	99,6	6,3	●	●	10	-

*X = Explosion-proof version

P₁ = Power absorbed by the motor

P₂ = Power rated by the motor

I_N = Rated current

I_S = Starting current

- The electric pumps are suitable for S1 continuous service with submersed motor and for S3 intermittent service (see relative degrees of intermittence in the table) with non-submersed motor.

S3 service stands for intermittent service consisting of 10 minute equal cycles of which the previous table indicates the minutes of the cycle during which the motor may operate (eg. : S3 = 25%. operation consists of a repetitive sequence of 2,5 minutes operation and 7,5 minutes at a standstill). See standard CEI EN 60034-1

- The electric motors are produced in the following voltage ratings: 400 V ± 10% standard; 230 V ± 10% on request.

Other voltages on request.

*X = Version antideflagrante

P₁ = Puissance absorbée par le moteur

P₂ = Puissance restituée par le moteur

I_N = Intensité nominale

I_S = Intensité au démarrage

- L'électropompe est apte à fonctionner en service continu S1 avec le moteur complètement immergé, en service intermittent S3 moteur non immergé (se reporter aux valeurs d'intermittence mentionnées dans le tableau).

Le service S3 indique un fonctionnement intermittent par cycles identiques de 10 minutes. Le tableau ci-dessus indique le temps de marche du moteur en minutes pour 1 cycle de 10 minutes (Ex. : S3 = 25% chaque cycle sera composé de 2,5 minutes de marche et de 7,5 minutes d'arrêt). Voir norme CEI EN 60034-1.

- Les moteurs électriques prévus doivent être alimentés aux tensions nominales suivantes: 400 V ± 10% standard; 230 V ± 10% sur demande.

Tensions différentes sur demande.

*X = Versione antideflagrante

P₁ = Potenza assorbita motore

P₂ = Potenza resa dal motore

I_N = Corrente nominale

I_S = Corrente di avviamento

- Le elettropompe sono atte a funzionare in servizio continuo S1 con motore immerso, in servizio intermittente S3 con motore non immerso (vedi relativi gradi di intermittenza nella tabella).

Il servizio S3 sta ad indicare un funzionamento intermittente composto da cicli tutti uguali di 10 minuti di cui si indicano i minuti del ciclo in cui il motore può funzionare (Es. : S3 = 25% il funzionamento è composto da una sequenza ripetitiva di 2,5 minuti di funzionamento e di 7,5 minuti di sosta). Vedi norma CEI EN 60034-1.

- I motori elettrici sono previsti per essere alimentati alle seguenti tensioni nominali di rete: 400 V ± 10% standard; 230 V ± 10% a richiesta.

Tensioni diverse su richiesta.

K+

DN 250÷500



- KCM250T
- KCD300T
- KCD350T
- KCD400U
- KCD500V

Performance ranges
Champs de performance
 Campi di prestazione

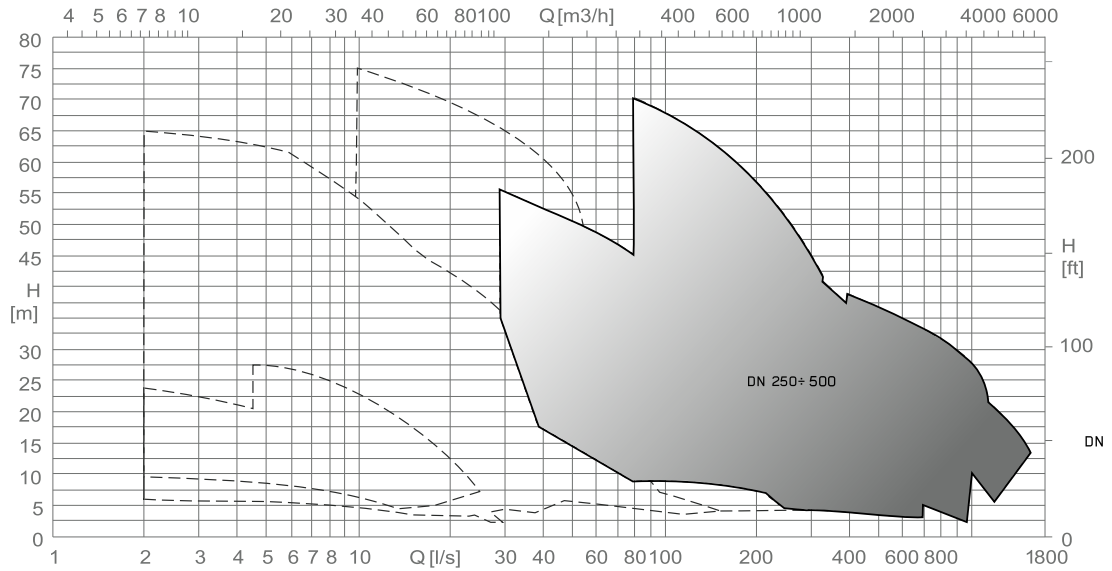

[Imp.g.p.m.]

20 30 40 60 100 200 400 600 1000 2000 6000 10000 20000

[US.g.p.m.]

20 30 40 60 100 200 400 600 1000 2000 4000 10000 20000

[l/min]

60 100 200 400 600 1000 2000 6000 10000 20000 40000 100000

K+

DN 250÷500

caprari

KCM250T
KCD300T
KCD350T

Construction and materials
Construction et matériaux
Costruzione e materiali

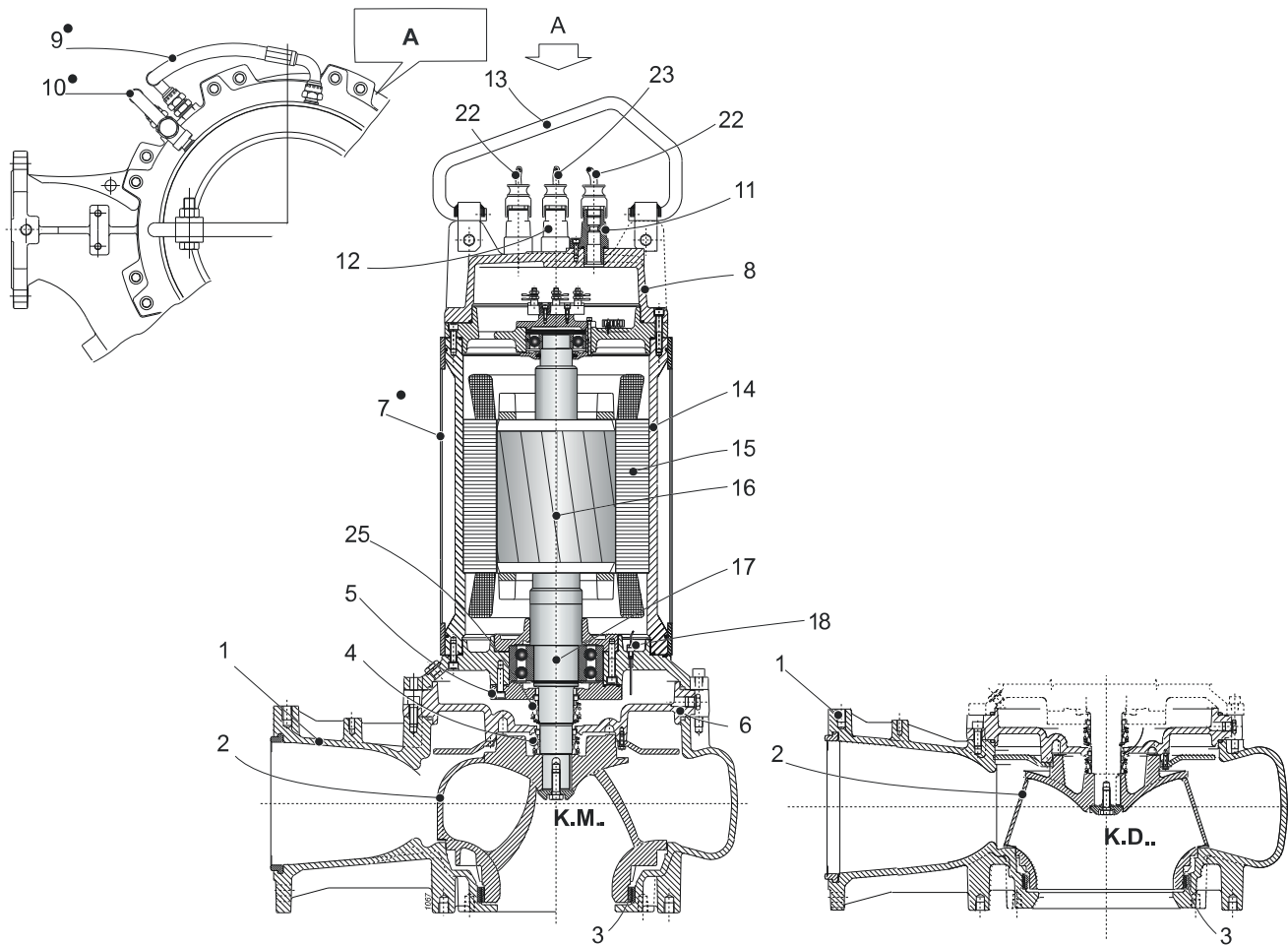

Pos.	Parts	Materials	Nomenclature	Matériaux	Nomenclatura	Materiale
1	Delivery body	Cast iron	Corps de refoulement	Fonte grise	Corpo mandata	Ghisa grigia
2	Impeller	Cast iron	Roue	Fonte grise	Girante	Ghisa grigia
3	Impeller wear ring	Steel/Rubber	Bague d'usure	Acier/Caoutchouc	Anello sede girante	Acciaio/Gomma
4	Conductivity probe	-	Sondes de conductivité	-	Sonda di conduttività	-
5	Mechanical seal on pump side	Silicon carbide/silicon carbide/ NBR	Garniture mécanique côté pompe	Carbure de silicium/ carbure de silicium/ NBR	Tenuta meccanica lato pompa	Carburo di silicio/ carburo di silicio/ NBR
6	Flange for mechanical seal	Cast iron	Bride porte garniture mécanique	Fonte grise	Flangia porta tenuta meccanica	Ghisa grigia
7	Support bearing	Nodular cast iron	Support de roulement	Fonte sphéroïdale	Supporto cuscinetto	Ghisa sferoidale
8	Oil box	Cast iron	Chambre à huile	Fonte grise	Scatola olio	Ghisa grigia
9	Handle	Stainless steel	Poignée	Acier inox	Maniglia	Acciaio inox
10	Motor casing	Cast iron	Enveloppe du moteur	Fonte grise	Carcassa motore	Ghisa grigia
11	Stator	Electrical steel	Stator	Tôle magnétique	Statore	Lamierino magnetico
12	Complete shaft with rotor	Stainless steel/ Magnetic steel	Arbre avec rotor	Acier inox/Tôle magnétique	Albero completo di rotore	Acciaio inox/ Lamierino magnetico
13	Flange for mechanical seal	Nodular cast iron	Bride porte garniture mécanique	Fonte sphéroïdale	Flangia porta tenuta meccanica	Ghisa sferoidale
14	Spacer sleeve	Cast iron	Entretoise	Fonte grise	Distributore	Ghisa grigia
16	Mechanical seal on motor side	Stainless steel/graphite	Garniture mécanique côté moteur	Acier inox/graphite	Tenuta meccanica lato motore	Acciaio inox/graphite
19	Cable clamp	Cast iron	Presse-étoupe	Fonte grise	Pressacavo	Ghisa grigia
20	Round power cable	-	Câble rond d'alimentation	-	Cavo tondo di alimentazione	-
22	Head cover	Cast iron	Couvercle tête	Fonte grise	Coperchio testata	Ghisa grigia

• Cooling system components (Version .../R)

Screws and nuts in stainless steel.
Available version with AISI 316 stainless steel impeller.

• Composant pour version avec système de refroidissement (Version .../R)

Vis et écrous en acier inox
Disponible version Avec roue en acier inox AISI 316.

• Componenti sistema di raffreddamento (Versione .../R)

Viti e dadi in acciaio inox
Disponibile versione con girante in acciaio inox AISI 316.

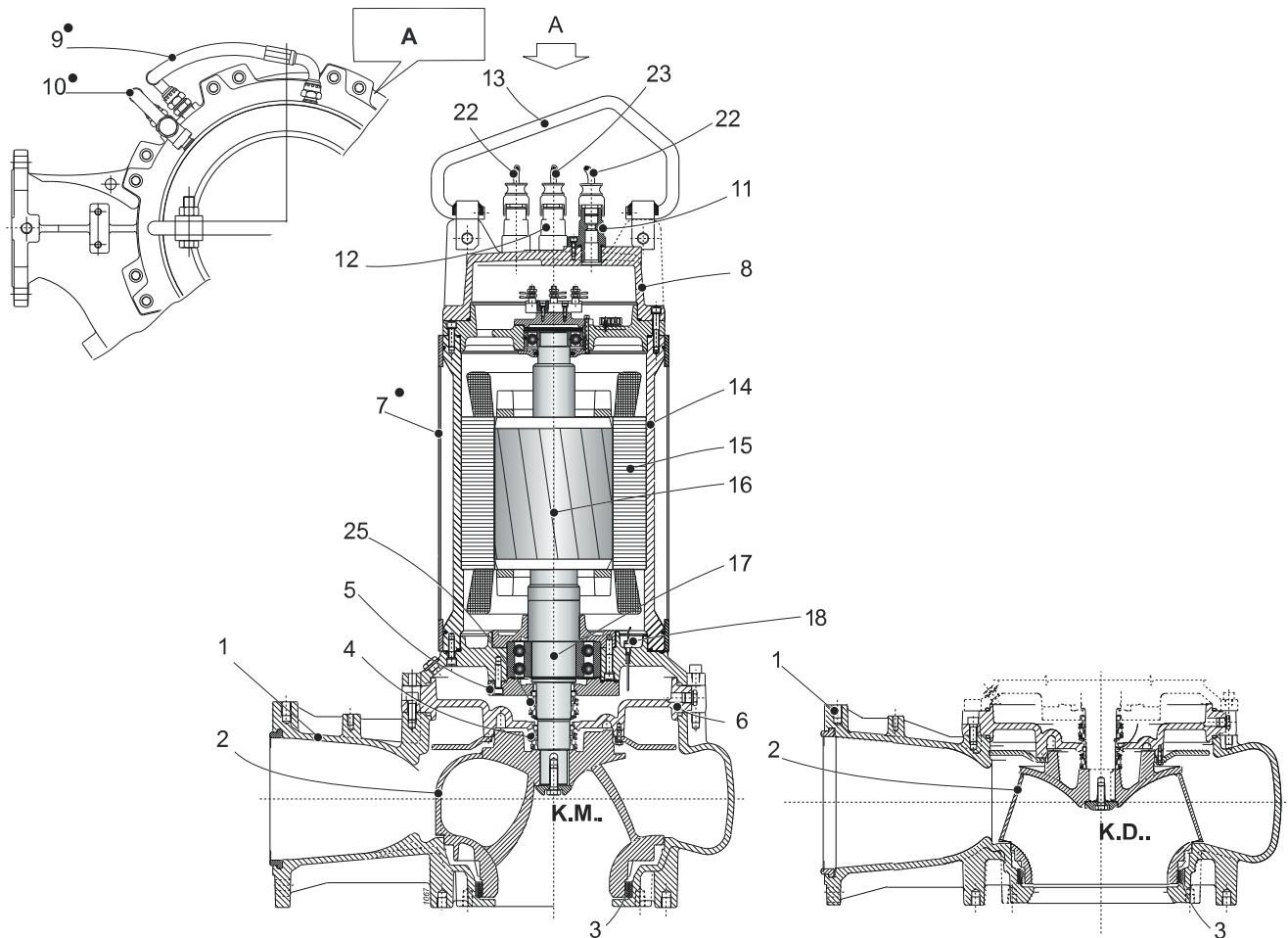

Pos.	Parts	Materials	Nomenclature	Matériaux	Nomenclatura	Materiale
1	Delivery body	Cast iron	Corps de refoulement	Fonte grise	Corpo mandata	Ghisa grigia
2	Impeller	Cast iron	Roue	Fonte grise	Girante	Ghisa grigia
3	Impeller wear ring	Steel/Rubber	Bague d'usure	Acier/Caoutchouc	Anello sede girante	Acciaio/Gomma
4	Mechanical seal on pump side	Silicon carbide/silicon carbide/NBR	Garniture mécanique côté pompe	Carbure de silicium/ carbure de silicium/ NBR	Tenuta meccanica lato pompa	Carburo di silicio/ carburo di silicio/NBR
5	Support bearing	Nodular cast iron	Support de roulement	Fonte sphéroïdale	Supporto cuscinetto	Ghisa sferoidale
6	Oil box	Cast iron	Chambre à huile	Fonte grise	Scatola olio	Ghisa grigia
8	Head cover	Cast iron	Couvercle tête	Fonte grise	Coperchio testata	Ghisa grigia
11 - 12	Cable clamp	Cast iron	Presse-étoupe	Fonte grise	Pressacavo	Ghisa grigia
13	Handle	Stainless steel	Poignée	Acier inox	Maniglia	Acciaio inox
14	Motor casing	Cast iron	Enveloppe du moteur	Fonte grise	Carcassa motore	Ghisa grigia
15	Stator	Electrical steel	Stator	Tôle magnétique	Statore	Lamierino magnetico
16	Rotor	Electrical steel	Rotor	Tôle magnétique	Rotore	Lamierino magnetico
17	Shaft	Stainless steel	Arbre	Acier inox	Albero	Acciaio inox
18	Conductivity probe	-	Sondes de conductivité	-	Sonda di conduttività	-
22	Round power cable	-	Câble rond d'alimentation	-	Cavo tondo di alimentazione	-
23	Round auxiliary cable	-	Câble rond auxiliaire	-	Cavo tondo ausiliario	-
25	Mechanical seal on motor side	Silicon carbide/silicon carbide/NBR	Garniture mécanique côté moteur	Carbure de silicium/ carbure de silicium/ NBR	Tenuta meccanica lato motore	Carburo di silicio/ carburo di silicio/NBR

• Cooling system components (Version .../R)

• Composant pour version avec système de refroidissement (Version .../R)

• Componenti sistema di raffreddamento (Versione .../R)

Screws and nuts in stainless steel.

Vis et écrous en acier inox

Viti e dadi in acciaio inox

Available version with AISI 316 stainless steel impeller.

Disponible version Avec roue en acier inox AISI 316.

Disponibile versione con girante in acciaio inox AISI 316.

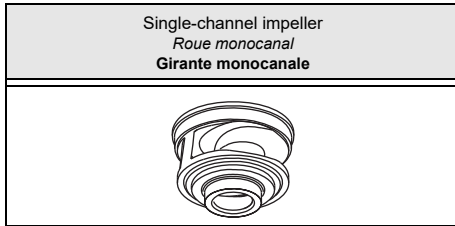

Type Type Tipo	KCM250T...42N3	
Thermal probes Sondes thermiques Sonda termiche	Yes Oui SI	
Conductivity probe Sonde de conductivité Sonda di conduttività	Yes Oui SI	

Version cable (1)
Version câble (1)
Cavo Versione (1)

Electric pump type Electropompe type Elettropompa tipo	Power supply Alimentazione	Auxiliary Auxiliaire Ausiliario
KCM250TL+100042N3	2x(4x50)x10	1x(4x1,5)x10
KCM250TH+100042N3	2x(4x50)x10	1x(4x1,5)x10
KCM250TG+120042N3	2x(4x50)x10	1x(4x1,5)x10
KCM250TE+145042N3	2x(4x50)x10	1x(4x1,5)x10
KCM250TD+145042N3	2x(4x50)x10	1x(4x1,5)x10
KCM250TB+145042N3	2x(4x50)x10	1x(4x1,5)x10
KCM250TA+180042N3	4x(4x50)x21	1x(4x1,5)x10

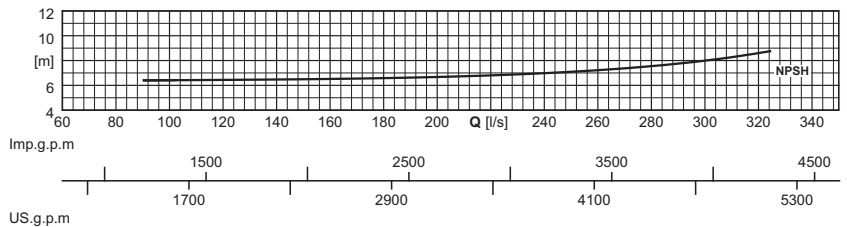
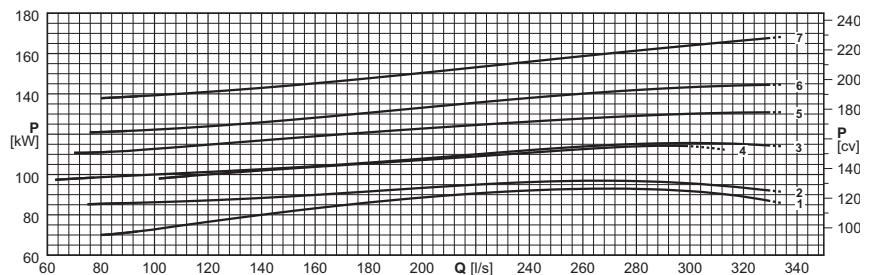
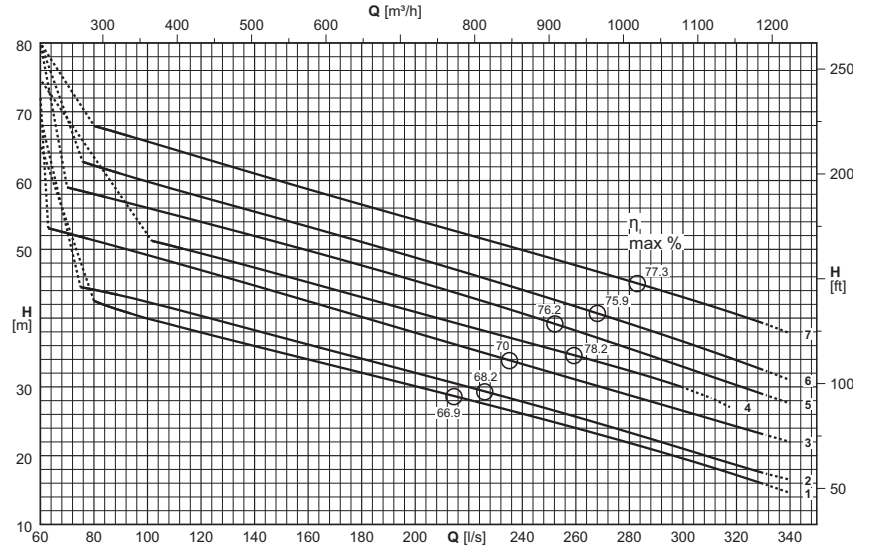

(1) = n°. of cables x (n°. of wires each cable x size [mm²] x cable length [m]) - Câble H07RN-F (OZOFLEX Plus)
Cable length exceeding 10 m on request

(1) = n°. câbles x (n°. conducteurs câble x section [mm²] x longueur câble [m]) - Câble H07RN-F (OZOFLEX Plus)
Sur demande longueur de câble supérieure à 10 m

(1) = n°. cavi x (n°. conduttori per cavo x sezione [mm²] x lunghezza cavo [m]) - Cavo H07RN-F (OZOFLEX Plus)
Lunghezza cavo superiore a 10 m - su richiesta

Electric pump type Electropompe type Elettropompa tipo	Curve Courbe Curva	Motor power Puiss. moteur Potenza motore	Capacity Débit Portata																	
			[l/s]	0	70	80	90	100	125	150	175	200	225	250	275	300	325	340		
			P ₂	[m ³ /h]	0	252	288	324	360	450	540	630	720	810	900	990	1080	1170	1224	
			(N°)	[kW]	Head Hauteur Prevalenza															
			[m]	[m]	55,3		42,5	41,2	40	37,4	35	32,5	30,1	27,6	25,1	22,4	19,6	16,5	14,6	
KCM250TL+100042N3	1	100	[m]	[m]	59,3		44,1	43,3	42,3	39,8	37,2	34,6	32,1	29,5	26,8	24	21	18,1	16,5	
KCM250TH+100042N3	2	100	[m]	[m]	62,4	52,3	51,3	50,2	49,2	46,4	43,6	40,7	37,9	35	32,2	29,4	26,5	23,7	22	
KCM250TG+120042N3	3	120	[m]	[m]	64,7					48,9	46,3	43,6	40,9	38,2	35,6	32,9	29,9			
KCM250TE+145042N3	4	145	[m]	[m]	70,8	59	58	57	56	53,5	50,9	48,2	45,4	42,5	39,4	36,2	32,9	29,6	27,6	
KCM250TD+145042N3	5	145	[m]	[m]	74,1		62,2	61	59,9	57,1	54,4	51,6	48,8	45,9	42,9	39,8	36,4	33,2	31	
KCM250TB+145042N3	6	145	[m]	[m]	78,1			66,8	65,7	62,8	59,9	57,1	54,3	51,6	48,8	46	43	39,9	37,8	
KCM250TA+180042N3	7	180	[m]	[m]				6,4	6,4	6,4	6,5	6,6	6,7	6,8	7,1	7,5	8	8,8		
NPSH _R			[m]	[m]				6,4	6,4	6,4	6,5	6,6	6,7	6,8	7,1	7,5	8	8,8		

P₂ = Power rated by the motor
Performance tolerance as per:
UNI/ISO 9906 Grade 3B
For motor performances specification see page "motor features"
For the accessories specification see page "Accessories"

P₂ = Puissance restituée par le moteur
Tolérances sur les performances selon normes:
UNI/ISO 9906 Niveau 3B
Pour caractéristiques techniques moteurs voir page "Caractéristiques des moteurs"
Pour les accessoires voir page "Accessories"

P₂ = Potenza resa dal motore
Tolleranze sulle prestazioni secondo norme:
UNI/ISO 9906 Grado 3B
Per caratteristiche motori vedere pagina "caratteristiche motori"
Per accessori vedere pagina accessori

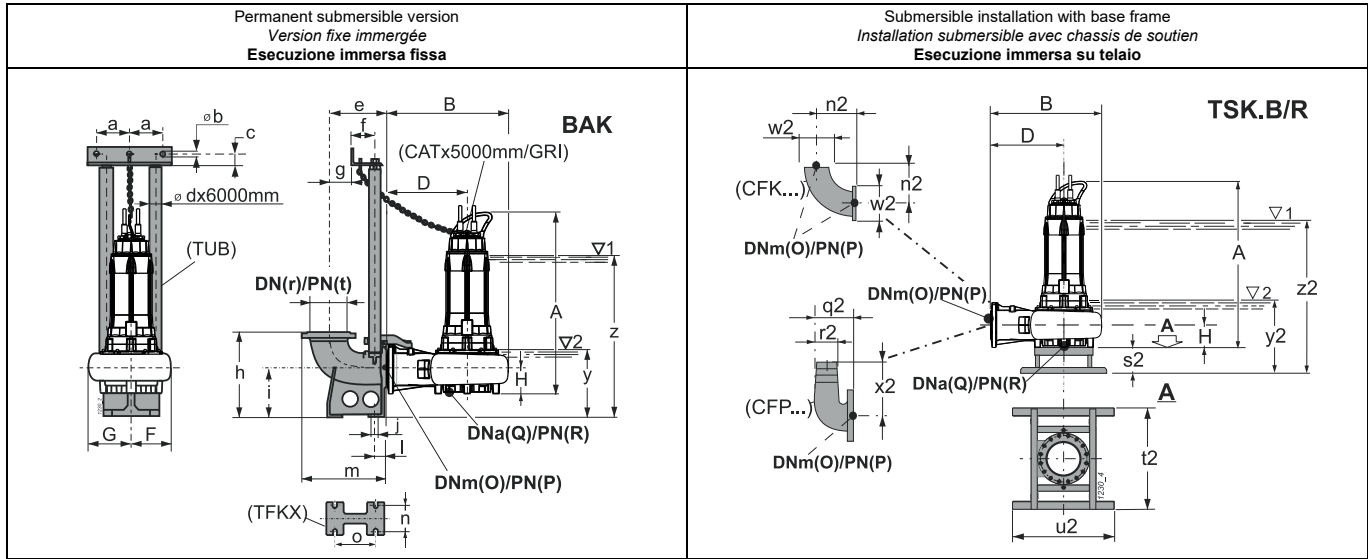

For fixed installation in a dry chamber - vertical (R)
Pour installation fixe en fosse sèche - verticale (R)
Esecuzione per camera asciutta - verticale (R)

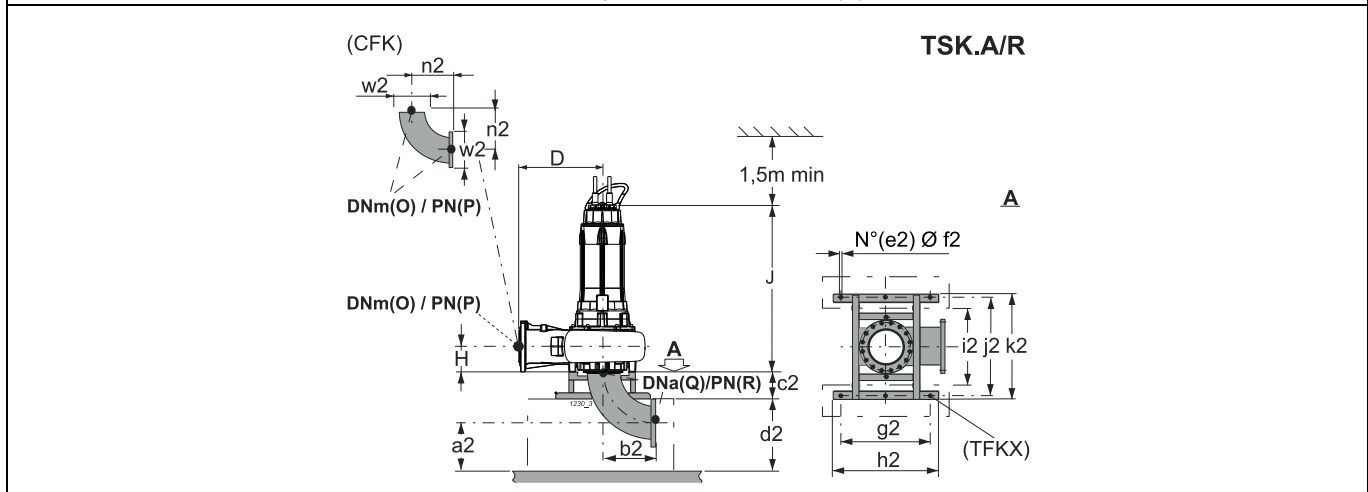

Type Type Tipo	Free passage Passage libre Passaggio Libero	Weight Poids Peso	[mm]												Accessories Accessoires Accessori		
			A	B	D	F	G	H	J	O	P	Q	R	BAK.	TSK.A/R	TSK.B/R	
KCM250TL+100042N3	Ø 163	1412,39	2228,4	937	570	329	407	220	-	250	10	250	10	300/250 3"	-	350	
KCM250TL+100042N3/R	Ø 163	1468,49	2228,4	937	570	329	407	220	1817	250	10	250	10	300/250 3"	250	-	
KCM250TH+100042N3	Ø 163	1412,9	2228,4	937	570	329	407	220	-	250	10	250	10	300/250 3"	-	350	
KCM250TH+100042N3/R	Ø 163	1469	2228,4	937	570	329	407	220	1817	250	10	250	10	300/250 3"	250	-	
KCM250TG+120042N3	Ø 163	1578,65	2364,4	937	570	329	407	220	-	250	10	250	10	300/250 3"	-	350	
KCM250TG+120042N3/R	Ø 163	1634,75	2364,4	937	570	329	407	220	1953	250	10	250	10	300/250 3"	250	-	
KCM250TE+145042N3	Ø 163	1668,92	2364,4	937	570	329	407	220	-	250	10	250	10	300/250 3"	-	350	
KCM250TE+145042N3/R	Ø 163	1725,02	2364,4	937	570	329	407	220	1953	250	10	250	10	300/250 3"	250	-	
KCM250TD+145042N3	Ø 163	1669,43	2364,4	937	570	329	407	220	-	250	10	250	10	300/250 3"	-	350	
KCM250TD+145042N3/R	Ø 163	1725,53	2364,4	937	570	329	407	220	1953	250	10	250	10	300/250 3"	250	-	
KCM250TB+145042N3	Ø 163	1669,94	2364,4	937	570	329	407	220	-	250	10	250	10	300/250 3"	-	350	
KCM250TB+145042N3/R	Ø 163	1726,04	2364,4	937	570	329	407	220	1953	250	10	250	10	300/250 3"	250	-	
KCM250TA+180042N3	Ø 163	1744,91	2364,4	937	570	329	407	220	-	250	10	250	10	300/250 3"	-	350	
KCM250TA+180042N3/R	Ø 163	1801,01	2364,4	937	570	329	407	220	1953	250	10	250	10	300/250 3"	250	-	

BAK.	a	b	c	d	e	f	g	h	i	j	l	m	n	o	r	t	y	z
BAK300/250 3"	157,5	12,5	35	3"	450	117	245	700	400	24	85	673	310	425	300	10	630	1898
TSK.A/R	a2	b2	c2	d2	e2	f2	g2	h2	i2	j2	k2	n2	w2					
TSK250A/R	295	385	280	400	6	22	850	1000	740	935	1000	385	395					
TSK.B/R	n2	q2	r2	s2	t2	u2	w2	x2	y2	z2								
TSK350B/R	385	525	250	280	1000	1000	395	575	730	1998								

(3) z = Minimum submergence depth for motor without casing with continuous duty S1 (NPSHR permitting)

y = Minimum submergence depth for motor without casing with intermittent duty S3 (NPSHR permitting)

(3) z = Immersion minimum pour moteur sans chemise en service continu S1 (compatible avec le NPSHR)

y = Immersion minimum pour moteur sans chemise en service intermittent S3 (compatible avec le NPSHR)

(3) z = Immersion minima per motore senza mantello in funzione continuo S1 compatibilmente con l'NPSHR

y = Immersion minima con motore senza mantello in funzione intermittente S3 compatibilmente con l'NPSHR

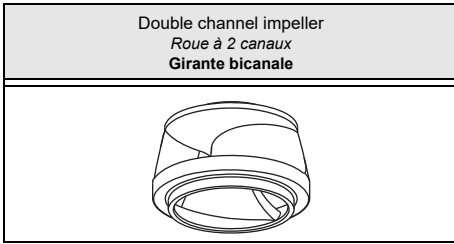

Type Type Tipo	KCD300T...+...42N3	
Thermal probes Sondes termiques Sonda termiche	Yes Oui Sì	
Conductivity probe Sonde de conductivité Sonda di conduttività	Yes Oui Sì	

Version cable (1)
Version câble (1)
Cavo Versione (1)

Electric pump type Electropompe type Elettropompa tipo	Power supply Alimentation Alimentazione	Auxiliary Auxiliaire Ausiliario
KCD300TP+090042N3/R	2x(4x50)x10	1x(4x1,5)x10
KCD300TM+090042N3	2x(4x50)x10	1x(4x1,5)x10
KCD300TL+100042N3/R	2x(4x50)x10	1x(4x1,5)x10
KCD300TI+100042N3	2x(4x50)x10	1x(4x1,5)x10
KCD300TH+120042N3/R	2x(4x50)x10	1x(4x1,5)x10
KCD300TG+120042N3	2x(4x50)x10	1x(4x1,5)x10
KCD300TE+145042N3/R	2x(4x50)x10	1x(4x1,5)x10
KCD300TD+145042N3	2x(4x50)x10	1x(4x1,5)x10
KCD300TB+180042N3/R	4x(4x50)x21	1x(4x1,5)x10
KCD300TA+180042N3	4x(4x50)x21	1x(4x1,5)x10

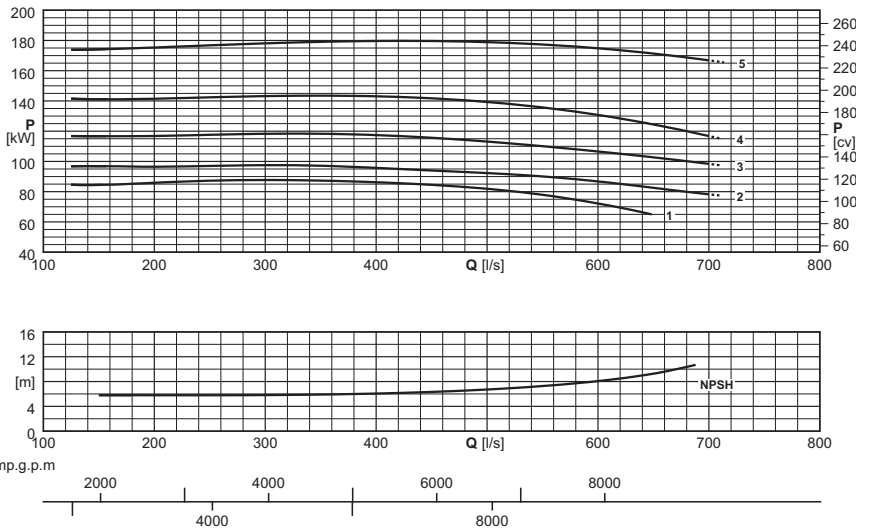
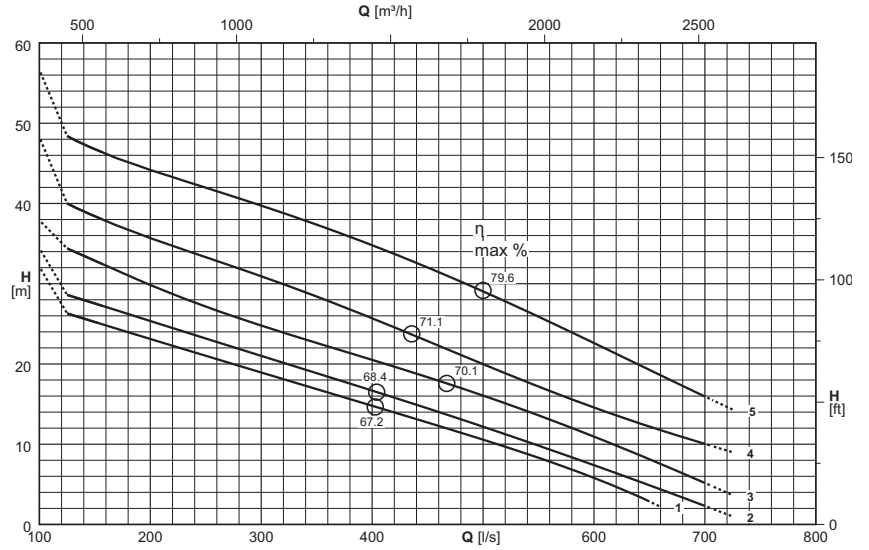

(1) = n°. of cables x (n°. of wires each cable x size [mm²] x cable length [m] - Cable H07RN-F (OZOFLEX Plus)
Cable length exceeding 10 m on request

(1) = n°. câbles x (n°. conducteurs câble x section [mm²] x longueur câble [m] - Câble H07RN-F (OZOFLEX Plus)
Sur demande longueur de câble supérieure à 10 m

(1) = n°. cavi x (n°. conduttori per cavo x sezione [mm²] x lunghezza cavo [m] - Cavo H07RN-F (OZOFLEX Plus)
Lunghezza cavo superiore a 10 m - su richiesta

Electric pump type Electropompe type Elettropompa tipo	Curve Courbe Curva	Motor power Puiss. moteur Potenza motore	Capacity Débit Portata																		
			[l/s]	0	130	150	175	200	250	300	350	400	450	500	550	600	650	700	726		
			P ₂	[m ³ /h]	0	468	540	630	720	900	1080	1260	1440	1620	1800	1980	2160	2340	2520	2613,6	
			(N°)	[kW]	Head Hauteur Prevalenza																
			[m]	[m]	32,1	26,1	25,2	24,2	23,1	21	18,9	16,9	14,8	12,7	10,6	8,3	5,8	2,8			
●KCD300TP+090042N3/R	1	90	[m]	[m]	32,1	26,1	25,2	24,2	23,1	21	18,9	16,9	14,8	12,7	10,6	8,3	5,8	2,8			
KCD300TM+090042N3	1	90	[m]	[m]	32,1	26,1	25,2	24,2	23,1	21	18,9	16,9	14,8	12,7	10,6	8,3	5,8	2,8			
●KCD300TL+100042N3/R	2	100	[m]	[m]	34,4	28,4	27,5	26,4	25,4	23,2	21	18,9	16,7	14,5	12,2	9,8	7,4	4,9	2,3		
KCD300TI+100042N3	2	100	[m]	[m]	34,4	28,4	27,5	26,4	25,4	23,2	21	18,9	16,7	14,5	12,2	9,8	7,4	4,9	2,3		
●KCD300TH+120042N3/R	3	120	[m]	[m]	37,9	34,1	32,9	31,3	29,9	27,2	24,8	22,6	20,5	18,3	16,1	13,6	10,9	8,1	5,2		
KCD300TG+120042N3	3	120	[m]	[m]	37,9	34,1	32,9	31,3	29,9	27,2	24,8	22,6	20,5	18,3	16,1	13,6	10,9	8,1	5,2		
●KCD300TE+145042N3/R	4	145	[m]	[m]	48,3	39,7	38,4	37	35,7	33,3	30,9	28,4	25,7	22,8	20	17,2	14,6	12,2	10		
KCD300TD+145042N3	4	145	[m]	[m]	48,3	39,7	38,4	37	35,7	33,3	30,9	28,4	25,7	22,8	20	17,2	14,6	12,2	10		
●KCD300TB+180042N3/R	5	180	[m]	[m]	56,6	48,1	46,8	45,4	44,2	42	39,7	37,4	34,8	32	29	25,9	22,6	19,3	15,9	14,3	
KCD300TA+180042N3	5	180	[m]	[m]	56,6	48,1	46,8	45,4	44,2	42	39,7	37,4	34,8	32	29	25,9	22,6	19,3	15,9	14,3	
NPSH _R			[m]	[m]			5,8	5,8	5,8	5,8	5,8	5,9	6,1	6,3	6,7	7,3	8,1	9,3	11,5		

● Fixed installation in a dry chamber (R)

○ Submersible version

P₂ = Power rated by the motor

Performance tolerance as per:

UNI/ISO 9906 Grade 3B

For motor performances specification see page "motor features"

For the accessories specification see page "Accessories"

The impellers will be trimmed to meet the duty point

● Installation fixe en fosse sèche (R)

○ Version immergée

P₂ = Puissance restituée par le moteur

Tolérances sur les performances selon normes:

UNI/ISO 9906 Niveau 3B

Pour caractéristiques techniques moteurs voir page "Caractéristiques des moteurs"

Pour les accessoires voir page "Accessories"

Le point de fonctionnement désiré peut être obtenu par rognage de roue

● Esecuzione per camera asciutta (R)

○ Esecuzione Immersa

P₂ = Potenza resa dal motore

Tolleranze sulle prestazioni secondo norme:

UNI/ISO 9906 Grado 3B

Per caratteristiche motori vedere pagina "caratteristiche motori"

Per accessori vedere pagina accessori

Le giranti vengono tornite in modo da ottenere il punto di lavoro richiesto

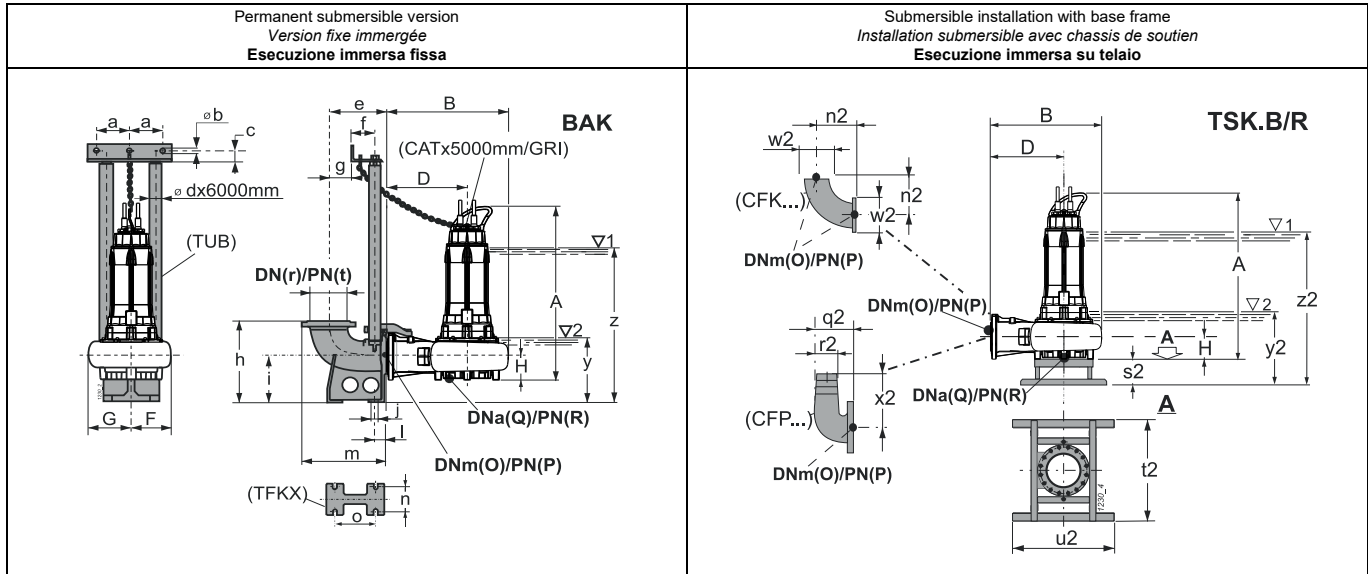

For fixed installation in a dry chamber - vertical (R) / Pour installation fixe en fosse sèche - verticale (R) / Esecuzione per camera asciutta - verticale (R)

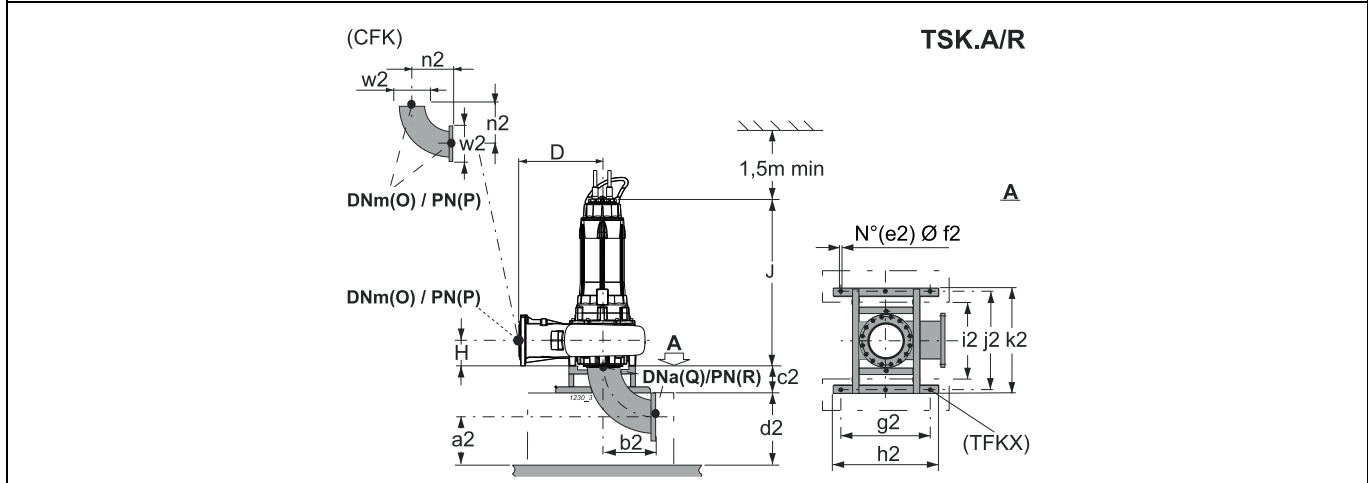

Type Type Tipo	Free passage Passage libre Passaggio Libero	Weight Poids Peso	[mm]											Accessories Accessoires Accessori		
			A	B	D	F	G	H	J	O	P	Q	R	BAK	TSK.A/R	TSK.B/R
●KCD300TP+090042N3/R	Ø 143	1484,07	-	-	620	-	-	230	1804	300	10	300	10	-	300	-
KCD300TM+090042N3	Ø 143	1429,97	2215,4	1030	620	340	480	230	-	300	10	300	10	350/300 3"	-	350
KCD300TM+090042N3/R	Ø 143	1484,97	2215,4	1030	620	340	480	230	-	300	10	300	10	350/300 3"	-	350
●KCD300TL+100042N3/R	Ø 143	1486,21	-	-	620	-	-	230	1804	300	10	300	10	-	300	-
KCD300TI+100042N3	Ø 143	1431,91	2215,4	1030	620	340	480	230	-	300	10	300	10	350/300 3"	-	350
KCD300TI+100042N3/R	Ø 143	1486,91	2215,4	1030	620	340	480	230	-	300	10	300	10	350/300 3"	-	350
●KCD300TH+120042N3/R	Ø 143	1653,43	-	-	620	-	-	230	1940	300	10	300	10	-	300	-
KCD300TG+120042N3	Ø 143	1598,25	2351,4	1030	620	340	480	230	-	300	10	300	10	350/300 3"	-	350
KCD300TG+120042N3/R	Ø 143	1653,25	2351,4	1030	620	340	480	230	-	300	10	300	10	350/300 3"	-	350
●KCD300TE+145042N3/R	Ø 143	1744,71	-	-	620	-	-	230	1940	300	10	300	10	-	300	-
KCD300TD+145042N3	Ø 143	1685,71	2351,4	1030	620	340	480	230	-	300	10	300	10	350/300 3"	-	350
KCD300TD+145042N3/R	Ø 143	1740,71	2351,4	1030	620	340	480	230	-	300	10	300	10	350/300 3"	-	350
●KCD300TB+180042N3/R	Ø 143	1821,89	-	-	620	-	-	230	1940	300	10	300	10	-	300	-
KCD300TA+180042N3	Ø 143	1822,3	2351,4	1030	620	340	480	230	-	300	10	300	10	350/300 3"	-	350
KCD300TA+180042N3/R	Ø 143	1877,3	2351,4	1030	620	340	480	230	-	300	10	300	10	350/300 3"	-	350

BAK	a	b	c	d	e	f	g	h	i	j	l	m	n	o	r	t	y	z
BAK350/300 3"	157,5	12,5	35	3"	500	117	295	820	500	24	90	755	360	475	350	10	707	1975
TSK.A/R	a2	b2	c2	d2	e2	f2	g2	h2	i2	j2	k2	n2	w2					
TSK300A/R	320	465	280	500	6	22	850	1000	740	935	1000	465	445					
TSK.B/R	n2	s2	t2	u2	w2	y2	z2											
TSK350B/R	465	280	1000	1000	445	717	1985											

(3) z = Minimum submergence depth for motor without casing with continuous duty S1 (NPSHR permitting) / (3) z = Immersion minima pour moteur sans chemise en service continu S1 (compatible avec le NPSHR) / (3) z = Immersion minima per motore senza mantello in funzione continuo S1 compatibilmente con l'NPSHR

y = Minimum submergence depth for motor without casing with intermittent duty S3 (NPSHR permitting) / y = Immersion minima pour moteur sans chemise en service intermittent S3 (compatible avec le NPSHR) / y = Immersion minima con motore senza mantello in funzione intermittente S3 compatibilmente con l'NPSHR

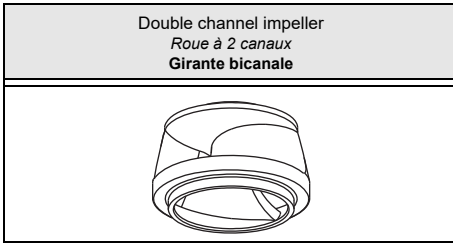

Type Type Tipo	KCD350T...62N3	
Thermal probes Sondes termiques Sonda termiche	Yes Oui SI	
Conductivity probe Sonde de conductivité Sonda di conduttività	Yes Oui SI	

Version cable (1)
Version câble (1)
Cavo Versione (1)

Electric pump type Electropompe type Elettropompa tipo	Power supply Alimentation Alimentazione	Auxiliary Auxiliaire Ausiliario
KCD350TP+060062N3/R	2x(4x50)x10	1x(4x1,5)x10
KCD350TO+060062N3	2x(4x50)x10	1x(4x1,5)x10
KCD350TH+082062N3/R	2x(4x50)x10	1x(4x1,5)x10
KCD350TG+082062N3	2x(4x50)x10	1x(4x1,5)x10
KCD350TB+100062N3/R	2x(4x50)x10	1x(4x1,5)x10
KCD350TA+100062N3	2x(4x50)x10	1x(4x1,5)x10

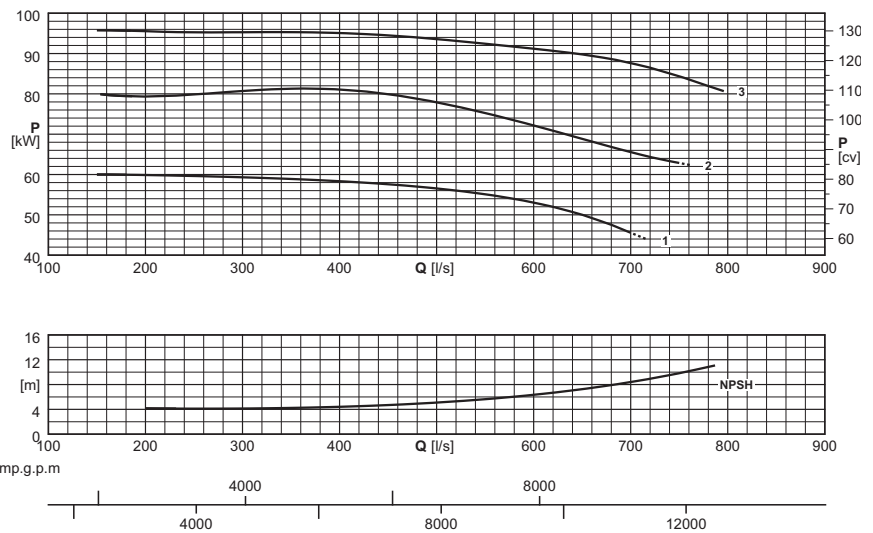
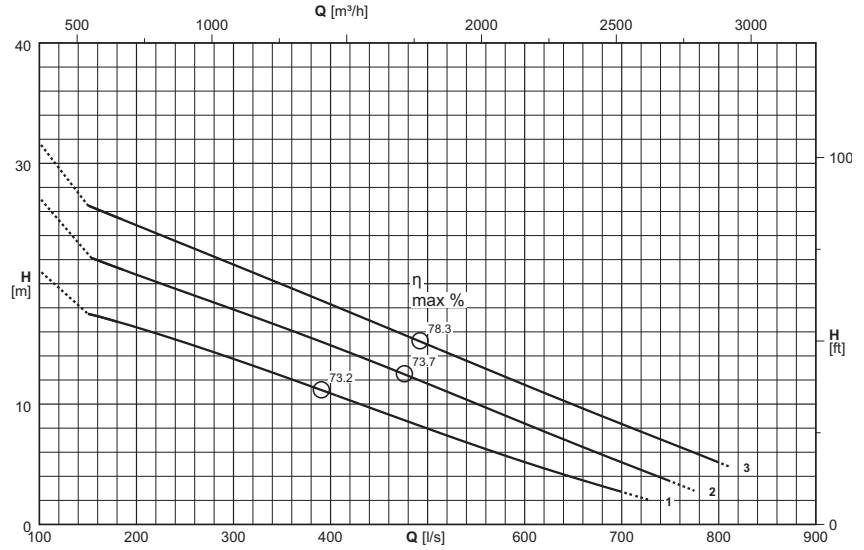

(1) = n°. of cables x (n°. of wires each cable x size [mm²]) x cable length [m] - Câble H07RN-F (OZOFLEX Plus)
Cable length exceeding 10 m on request

(1) = n°. câbles x (n°. conducteurs câble x section [mm²]) x longueur câble [m] - Câble H07RN-F (OZOFLEX Plus)
Sur demande longueur de câble supérieure à 10 m

(1) = n°. cavi x (n°. conduttori per cavo x sezione [mm²]) x lunghezza cavo [m] - Cavo H07RN-F (OZOFLEX Plus)
Lunghezza cavo superiore a 10 m - su richiesta

Electric pump type Electropompe type Elettropompa tipo	Curve Courbe Curva	Motor power Puiss. moteur Potenza motore	Capacity Débit Portata																			
			[l/s]	0	160	175	200	250	300	350	400	450	500	550	600	650	700	750	800	810		
			P ₂	[m ³ /h]	0	576	630	720	900	1080	1260	1440	1620	1800	1980	2160	2340	2520	2700	2880	2916	
			(N°)	[kW]	Head Hauteur Prevalenza																	
			[m]	[m]	21,1	17,3	17	16,4	15,1	13,8	12,3	10,9	9,4	8	6,5	5,2	3,9	2,7				
●KCD350TP+060062N3/R	1	60	[m]	[m]	21,1	17,3	17	16,4	15,1	13,8	12,3	10,9	9,4	8	6,5	5,2	3,9	2,7				
KCD350TO+060062N3	1	60	[m]	[m]	21,1	17,3	17	16,4	15,1	13,8	12,3	10,9	9,4	8	6,5	5,2	3,9	2,7				
●KCD350TH+082062N3/R	2	82	[m]	[m]	27,2	21,9	21,5	20,8	19,3	17,9	16,4	14,9	13,3	11,7	10	8,4	6,8	5,2	3,6			
KCD350TG+082062N3	2	82	[m]	[m]	27,2	21,9	21,5	20,8	19,3	17,9	16,4	14,9	13,3	11,7	10	8,4	6,8	5,2	3,6			
●KCD350TB+100062N3/R	3	100	[m]	[m]	31,7	26,2	25,7	24,9	23,2	21,6	19,9	18,3	16,6	14,9	13,3	11,6	10	8,3	6,8	5,2	4,8	
KCD350TA+100062N3	3	100	[m]	[m]	31,7	26,2	25,7	24,9	23,2	21,6	19,9	18,3	16,6	14,9	13,3	11,6	10	8,3	6,8	5,2	4,8	
NPSH _R			[m]	[m]				4,2	4,1	4,1	4,2	4,4	4,7	5,1	5,6	6,4	7,3	8,4	9,8	11,6		

● Fixed installation in a dry chamber (I/R)

○ Submersible version

P₂ = Power rated by the motor

Performance tolerance as per:

UNI/ISO 9906 Grade 3B

For motor performances specification see page "motor features"

For the accessories specification see page "Accessories"

The impellers will be trimmed to meet the duty point

● Installation fixe en fosse sèche (I/R)

○ Version immergée

P₂ = Puissance restituée par le moteur

Tolérances sur les performances selon normes:

UNI/ISO 9906 Niveau 3B

Pour caractéristiques techniques moteurs voir page "Caractéristiques des moteurs"

Pour les accessoires voir page "Accessories"

Le point de fonctionnement désiré peut être obtenu par rognage de roue

● Esecuzione per camera asciutta (I/R)

○ Esecuzione Immersa

P₂ = Potenza resa dal motore

Tolleranze sulle prestazioni secondo norme:

UNI/ISO 9906 Grado 3B

Per caratteristiche motori vedere pagina "caratteristiche motori"

Per accessori vedere pagina accessori

Le giranti vengono tornite in modo da ottenere il punto di lavoro richiesto

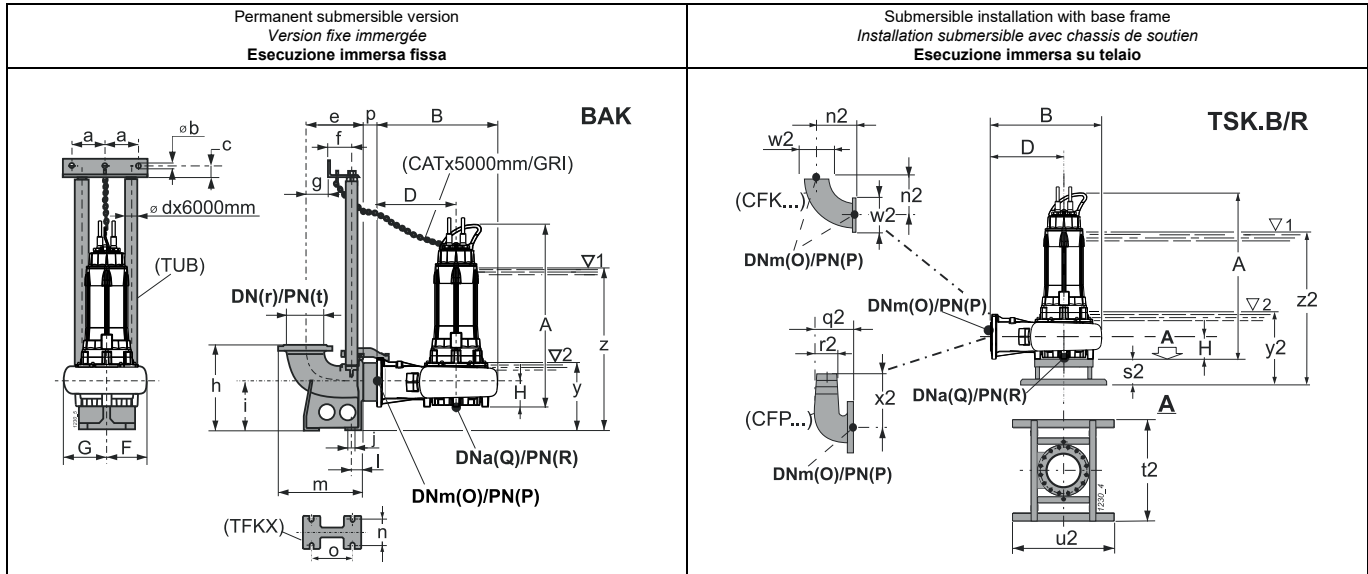

For fixed installation in a dry chamber - vertical (R) / Pour installation fixe en fosse sèche - verticale (R) / Esecuzione per camera asciutta - verticale (R)

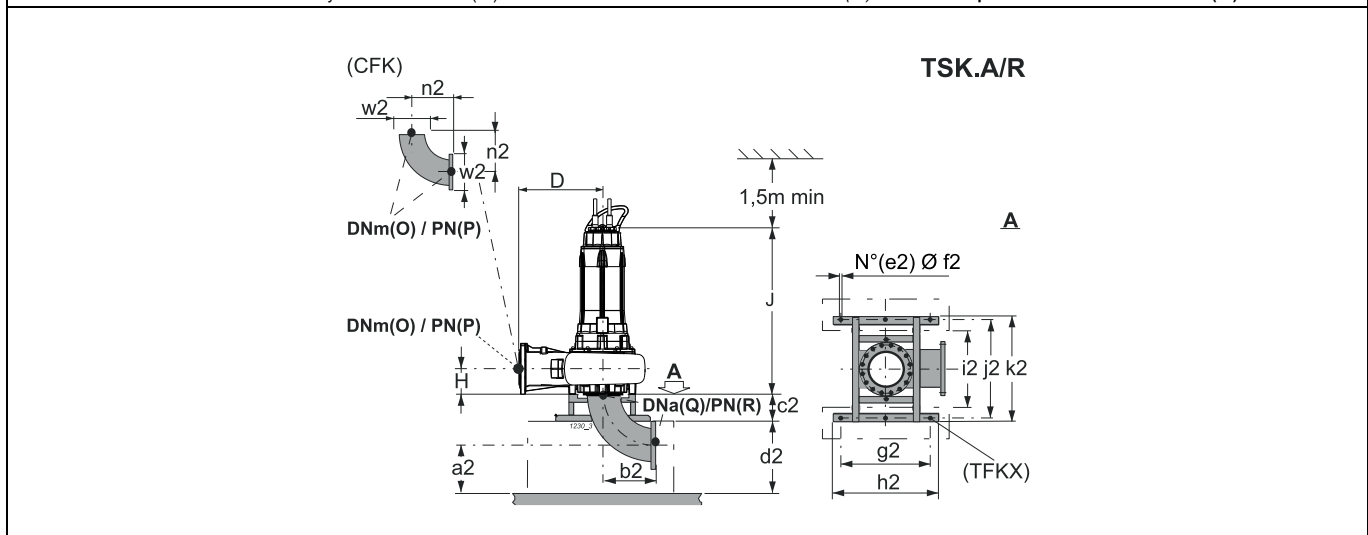

Type Type Tipo	Free passage Passage libre Passaggio Libero	Weight Poids Peso	[mm]											Accessories Accessoires Accessori							
			A	B	D	F	G	H	J	O	P	Q	R	BAK.	TSK.A/R	TSK.B/R					
●KCD350TP+060062N3/R	Ø 164	1514,7	-	-	700	-	-	268	1845	350	10	350	10	-	350	-					
KCD350TO+060062N3	Ø 164	1459,46	2256,4	1167,5	700	383,4	551,7	268	-	350	10	350	10	S400/350 3"	-	350					
KCD350TO+060062N3/R	Ø 164	1513,86	2256,4	1167,5	700	383,4	551,7	268	-	350	10	350	10	S400/350 3"	-	350					
●KCD350TH+082062N3/R	Ø 164	1671,84	-	-	700	-	-	268	1981	350	10	350	10	-	350	-					
KCD350TG+082062N3	Ø 164	1616,7	2392,4	1167,5	700	383,4	551,7	268	-	350	10	350	10	S400/350 3"	-	350					
KCD350TG+082062N3/R	Ø 164	1672,78	2392,4	1167,5	700	383,4	551,7	268	-	350	10	350	10	S400/350 3"	-	350					
●KCD350TB+100062N3/R	Ø 164	1744,15	-	-	700	-	-	268	1981	350	10	350	10	-	350	-					
KCD350TA+100062N3	Ø 164	1695,24	2392,4	1167,5	700	383,4	551,7	268	-	350	10	350	10	S400/350 3"	-	350					
KCD350TA+100062N3/R	Ø 164	1750	2392,4	1167,5	700	383,4	551,7	268	-	350	10	350	10	S400/350 3"	-	350					
BAK.			a	b	c	d	e	f	g	h	i	j	l	m	n	o	p	r	t	y	z
BAKS400/350 3"			157,5	12,5	35	3"	525	117	320	920	575	24	95	810	400	510	50	400	10	785	2053
TSK.A/R			a2	b2	c2	d2	e2	f2	g2	h2	i2	j2	k2	n2	w2						
TSK350A/R			345	540	280	600	6	22	850	1000	740	935	1000	540	505						
TSK.B/R			n2	s2	t2	u2	w2	y2	z2												
TSK350B/R			540	280	1000	1000	505	758	2026												

(3) z = Minimum submergence depth for motor without casing with continuous duty S1 (NPSHR permitting)

y = Minimum submergence depth for motor without casing with intermittent duty S3 (NPSHR permitting)

(3) z = Immersion minimum pour moteur sans chemise en service continu S1 (compatible avec le NPSHR)

y = Immersion minimum pour moteur sans chemise en service intermittent S3 (compatible avec le NPSHR)

(3) z = Immersion minima per motore senza mantello in funzione continuo S1 compatibilmente con l'NPSHR

y = Immersion minima con motore senza mantello in funzione intermittente S3 compatibilmente con l'NPSHR

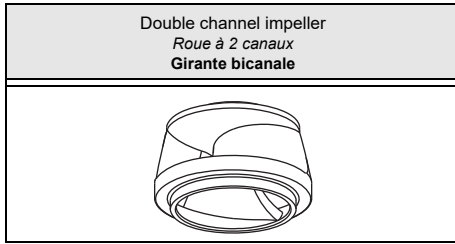

Type Type Tipo	KCD400U...62N1	
Thermal probes Sondes termiques Sonde termiche	Yes Oui SI	
Conductivity probe Sonde de conductivité Sonda di conduttività	Yes Oui SI	

Version cable (1) Version câble (1) Cavo Versione (1)		
Electric pump type Electropompe type Elettropompa tipo	Power supply Alimentation Alimentazione	Auxiliary Auxiliaire Ausiliario
KCD400UL+145062N1	2x(4x70)x10	1x(5x1,5)x10
KCD400UG+180062N1	4x(4x35)x10	1x(5x1,5)x10
KCD400UD+220062N1	4x(4x50)x10	1x(5x1,5)x10
KCD400UA+260062N1	4x(4x70)x10	1x(5x1,5)x10

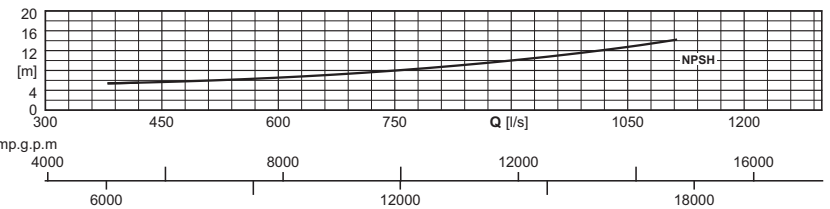
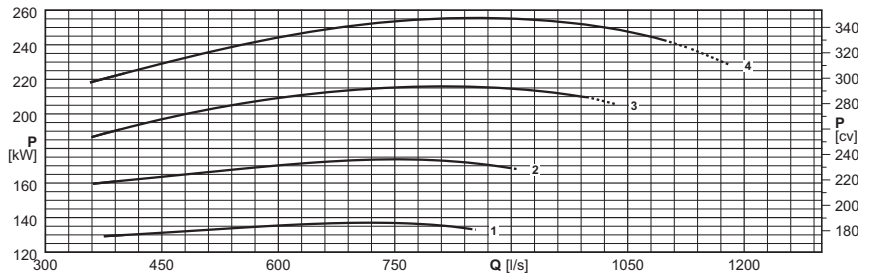
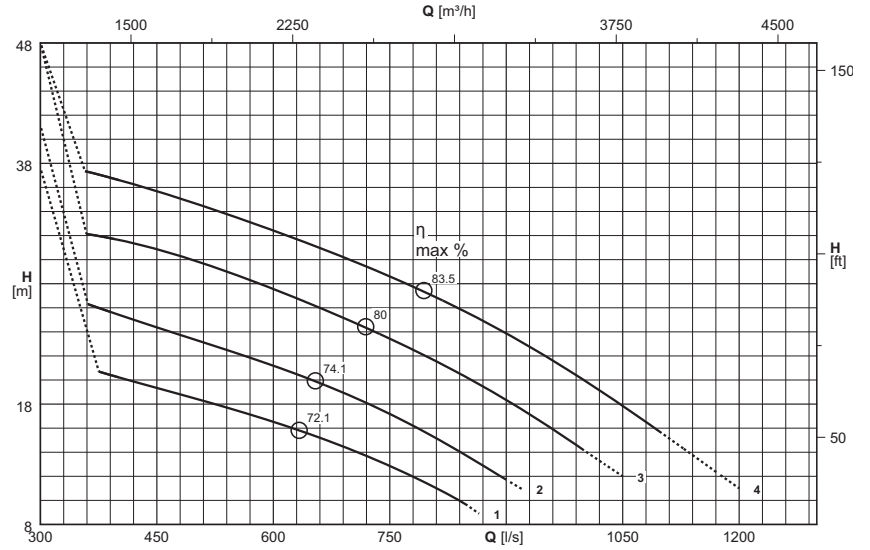

(1) = n°. of cables x (n°. of wires each cable x size [mm²]) x cable length [m] - Câble H07RN-F (OZOFLEX Plus)

Cable length exceeding 10 m on request

(1) = n°. câbles x (n°. conducteurs câble x section [mm²]) x longueur câble [m] - Câble H07RN-F (OZOFLEX Plus)

Sur demande longueur de câble supérieure à 10 m

(1) = n°. cavi x (n°. conduttori per cavo x sezione [mm²]) x lunghezza cavo [m] - Cavo H07RN-F (OZOFLEX Plus)

Lunghezza cavo superiore a 10 m - su richiesta

Electric pump type Electropompe type Elettropompa tipo	Curve Courbe Curva	Motor power Puiss. moteur Potenza motore	Capacity Débit Portata																				
			[l/s]	0	375	400	450	500	550	600	650	700	750	800	850	900	950	1000	1050	1100	1150	1200	
		P ₂	[m ³ /h]	0	1350	1440	1620	1800	1980	2160	2340	2520	2700	2880	3060	3240	3420	3600	3780	3960	4140	4320	
	(N°)	[kW]	Head Hauteur Prevalenza																				
KCD400UL+145062N1	1	145	[m]	29,6		20,2	19,3	18,4	17,5	16,5	15,4	14,2	12,9	11,3	9,5								
KCD400UG+180062N1	2	180	[m]	33,1	26	25,4	24,4	23,3	22,3	21,2	20	18,7	17,2	15,5	13,7	11,7							
KCD400UD+220062N1	3	220	[m]	40,2	31,9	31,6	30,8	29,9	28,8	27,6	26,3	24,9	23,4	21,9	20,2	18,3	16,3	14,2	12				
KCD400UA+260062N1	4	260	[m]	45,8	37,1	36,6	35,7	34,6	33,6	32,4	31,2	29,9	28,6	27,2	25,6	23,9	22	20	17,8	15,6	13,3	11	
NPSH _R			[m]			5,5	5,7	5,9	6,2	6,6	7	7,4	8	8,6	9,3	10	10,8	11,7	12,7	13,9			

P₂ = Power rated by the motor
Performance tolerance as per:
UNI/ISO 9906 Grade 3B

For motor performances specification see page "motor features"

For the accessories specification see page "Accessories"

The impellers will be trimmed to meet the duty point

P₂ = Puissance restituée par le moteur
Tolérances sur les performances selon normes:
UNI/ISO 9906 Niveau 3B

Pour caractéristiques techniques moteurs voir page "Caractéristiques des moteurs"

Pour les accessoires voir page "Accessories"

Le point de fonctionnement désiré peut être obtenu par rognage de roue

P₂ = Potenza resa dal motore

Tolleranze sulle prestazioni secondo norme:
UNI/ISO 9906 Grado 3B

Per caratteristiche motori vedere pagina "caratteristiche motori"

Per accessori vedere pagina accessori

Le giranti vengono tornite in modo da ottenere il punto di lavoro richiesto

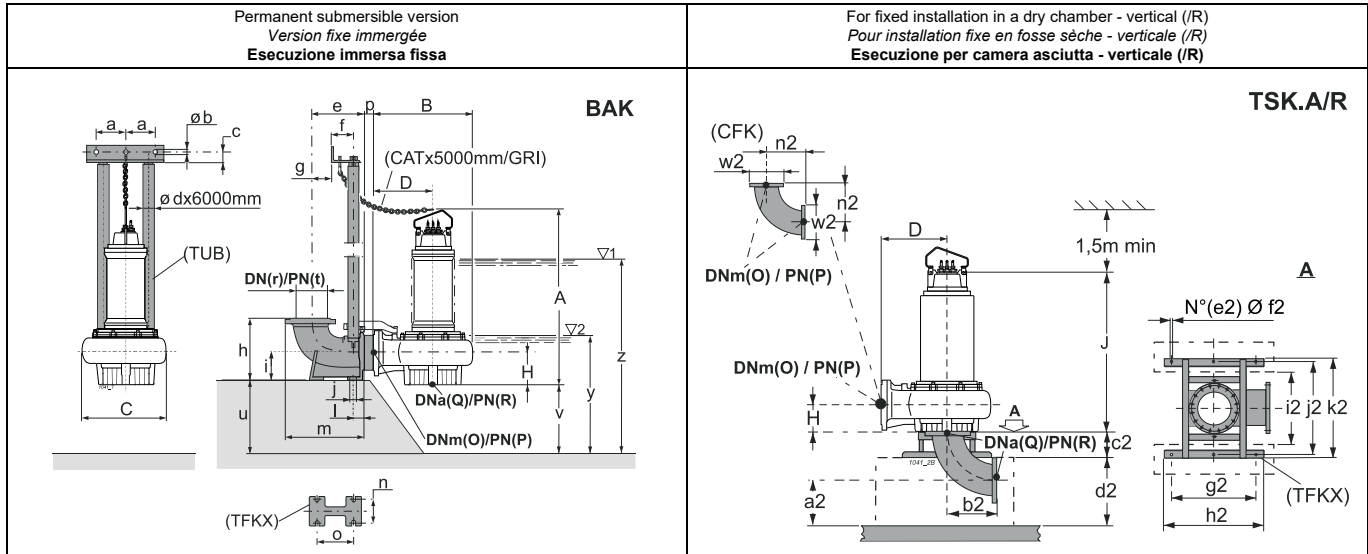

For fixed installation in a dry chamber - horizontal (R)
 Pour installation fixe en fosse sèche - horizontale (R)
 Esecuzione per camera asciutta - orizzontale (R)

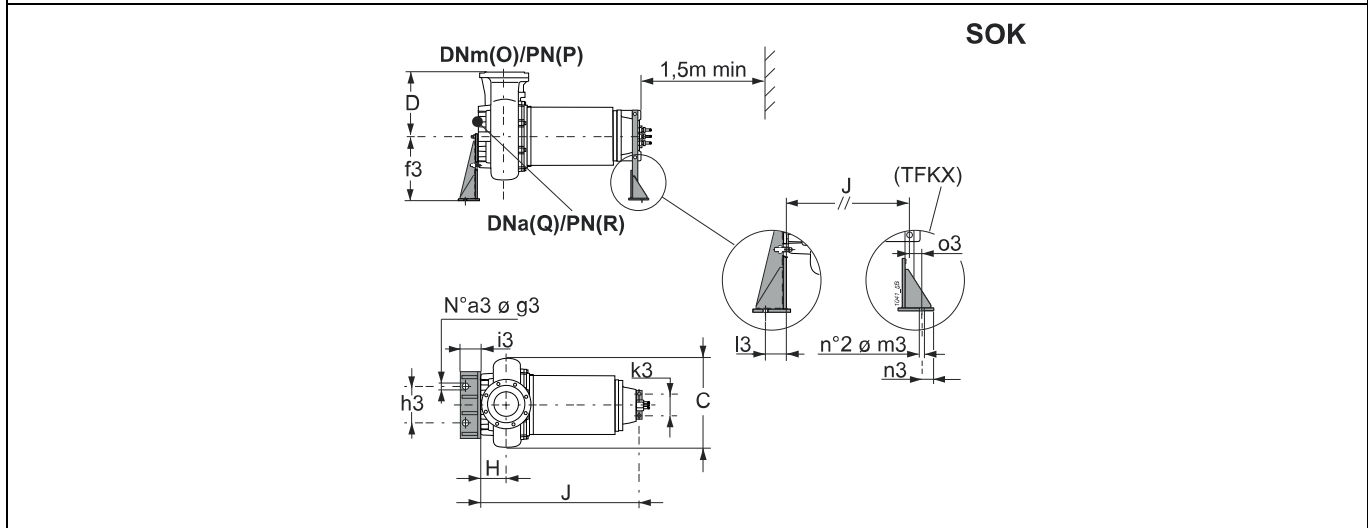

Type Type Tipo	Free passage Passage libre Passaggio Libero	Weight Poids Peso	A	B	C	D	H	J	O	P	Q	R	Accessories Accessoires Accessori								
			[mm]	[kg]	[mm]										BAK.	SOK.	TSK.A				
KCD400UL+145062N1	Ø 110	2390	2516	1390	1074	850	352	-	400	10	400	10	400/400 3"	-	-						
KCD400UL+145062N1/R	Ø 110	2610	2516	1390	1074	850	352	2138	400	10	400	10	400/400 3"	400	400						
KCD400UG+180062N1	Ø 110	2450	2516	1390	1074	850	352	-	400	10	400	10	400/400 3"	-	-						
KCD400UG+180062N1/R	Ø 110	2670	2516	1390	1074	850	352	2138	400	10	400	10	400/400 3"	400	400						
KCD400UD+220062N1	Ø 110	2980	2716	1390	1074	850	352	-	400	10	400	10	400/400 3"	-	-						
KCD400UD+220062N1/R	Ø 110	3240	2716	1390	1074	850	352	2338	400	10	400	10	400/400 3"	400	400						
KCD400UA+260062N1	Ø 110	3120	2716	1390	1074	850	352	-	400	10	400	10	400/400 3"	-	-						
KCD400UA+260062N1/R	Ø 110	3380	2716	1390	1074	850	352	2338	400	10	400	10	400/400 3"	400	400						
BAK.	a	b	c	d	e	f	g	h	i	j	l	m	n	o	p	r	t	u	v	y	z
BAK400/400 3"	157,5	12,5	35	3"	675	117	440	750	300	28	120	975,5	580	615	57	400	10	300	250	1150	2100
SOK.	a3	f3	g3	h3	i3	k3	l3	m3	n3	o3											
SOK400	3	690	22	640	180	270	100	22	100	20											
TSK.A	a2	b2	c2	d2	e2	f2	g2	h2	i2	j2	k2	n2	w2								
TSK400A	375	620	285	710	6	26	1050	1150	850	1130	1259	620	565								

(3) z = Minimum submergence depth for motor without casing with continuous duty S1 (NPSHR permitting)
 y = Minimum submergence depth for motor without casing with intermittent duty S3 (NPSHR permitting)

(3) z = Immersion minimum pour moteur sans chemise en service continu S1 (compatible avec le NPSHR)
 y = Immersion minimum pour moteur sans chemise en service intermittent S3 (compatible avec le NPSHR)

(3) z = Immersion minima per motore senza mantello in funzione continuo S1 compatibilmente con l'NPSHR
 y = Immersione minima con motore senza mantello in funzione intermittente S3 compatibilmente con l'NPSHR

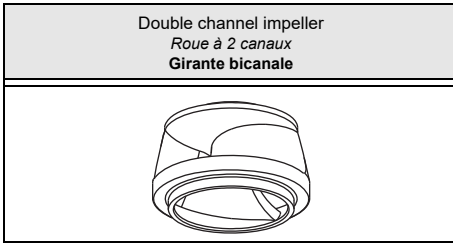

Type Type Tipo	KCD500V...62N1	
Thermal probes Sondes termiques Sonde termiche	Yes Oui SI	
Conductivity probe Sonde de conductivité Sonda di conduttività	Yes Oui SI	

Version cable (1)
Version câble (1)
Cavo Versione (1)

Electric pump type Electropompe type Elettropompa tipo	Power supply Alimentation Alimentazione	Auxiliary Auxiliaire Ausiliario
KCD500VP+145062N1	2x(4x70)x10	1x(5x1,5)x10
KCD500VL+180062N1	4x(4x35)x10	1x(5x1,5)x10
KCD500VG+220062N1	4x(4x50)x10	1x(5x1,5)x10
KCD500VD+275062N1	4x(4x70)x10	1x(5x1,5)x10
KCD500VA+345062N1	4x(4x95)x10	1x(5x1,5)x10

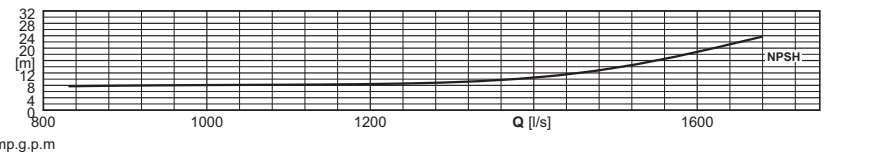
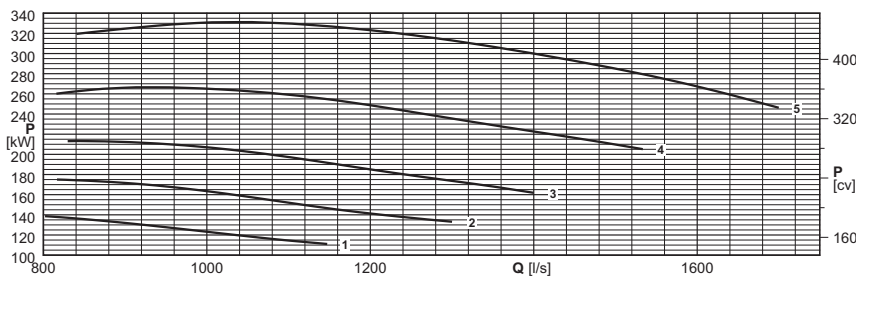
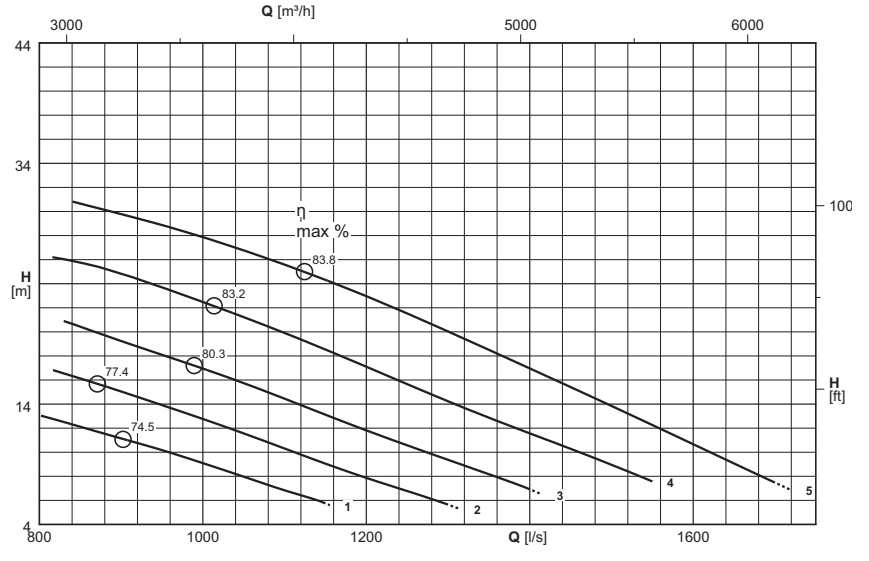

(1) = n°. of cables x (n°. of wires each cable x size [mm²]) x cable length [m] - Câble H07RN-F (OZOFLEX Plus)
Cable length exceeding 10 m on request

(1) = n°. câbles x (n°. conducteurs câble x section [mm²]) x longueur câble [m] - Câble H07RN-F (OZOFLEX Plus)
Sur demande longueur de câble supérieure à 10 m

(1) = n°. cavi x (n°. conduttori per cavo x sezione [mm²]) x lunghezza cavo [m] - Cavo H07RN-F (OZOFLEX Plus)
Lunghezza cavo superiore a 10 m - su richiesta

Electric pump type Electropompe type Elettropompa tipo	Curve Courbe Curva	Motor power Puiss. moteur Potenza motore	Capacity Débit Portata																							
			[l/s]	0	800	850	900	950	1000	1050	1100	1150	1200	1250	1300	1350	1400	1450	1500	1550	1600	1650	1700	1720		
		P ₂	[m³/h]	0	2880	3060	3240	3420	3600	3780	3960	4140	4320	4500	4680	4860	5040	5220	5400	5580	5760	5940	6120	6192		
	(N°)	[kW]	Head Hauteur Prevalenza																							
			[m]	20	13,1	12,1	11,1	10,2	9,1	8	6,8	5,7														
KCD500VP+145062N1	1	145	[m]	25	17,2	16,1	15	13,9	12,8	11,6	10,3	9,1	7,9	6,8	5,6											
KCD500VL+180062N1	2	180	[m]	30	21,5	20,4	19,2	18,1	16,9	15,7	14,4	13,1	11,8	10,6	9,4	8,2	6,9									
KCD500VG+220062N1	3	220	[m]	35	26,4	25,7	24,8	23,7	22,5	21,2	19,9	18,5	17,1	15,7	14,2	12,9	11,6	10,3	9	7,6						
KCD500VD+275062N1	4	275	[m]	40	31,6	30,7	29,8	28,9	27,9	26,8	25,6	24,3	23	21,5	20	18,5	17	15,4	13,8	12,3	10,7	9,1	7,5	6,9		
KCD500VA+345062N1	5	345	[m]		7,6	7,8	7,9	8	8,1	8,1	8,2	8,3	8,4	8,6	9	9,6	10,5	11,9	13,7	16	18,8	21,9	25			

P₂ = Power rated by the motor
Performance tolerance as per:
UNI/ISO 9906 Grade 3B
For motor performances specification see page "motor features"

P₂ = Puissance restituée par le moteur
Tolérances sur les performances selon normes:
UNI/ISO 9906 Niveau 3B
Pour caractéristiques techniques moteurs voir page "Caractéristiques des moteurs"
Pour les accessoires voir page "Accessories"
Le point de fonctionnement désiré peut être obtenu par rognage de roue

P₂ = Potenza resa dal motore
Tolleranze sulle prestazioni secondo norme:
UNI/ISO 9906 Grado 3B
Per caratteristiche motori vedere pagina "caratteristiche motori"
Per accessori vedere pagina accessori
Le giranti vengono tornite in modo da ottenere il punto di lavoro richiesto

For the accessories specification see page "Accessories"
The impellers will be trimmed to meet the duty point

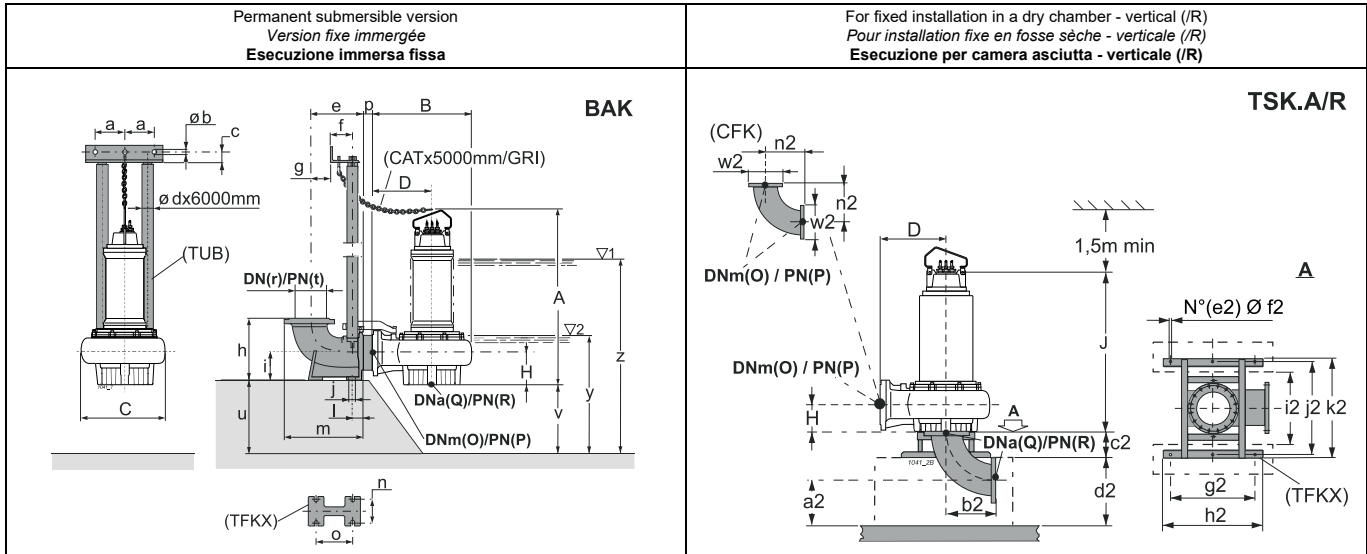

For fixed installation in a dry chamber - horizontal (R)
 Pour installation fixe en fosse sèche - horizontale (R)
 Esecuzione per camera asciutta - orizzontale (R)

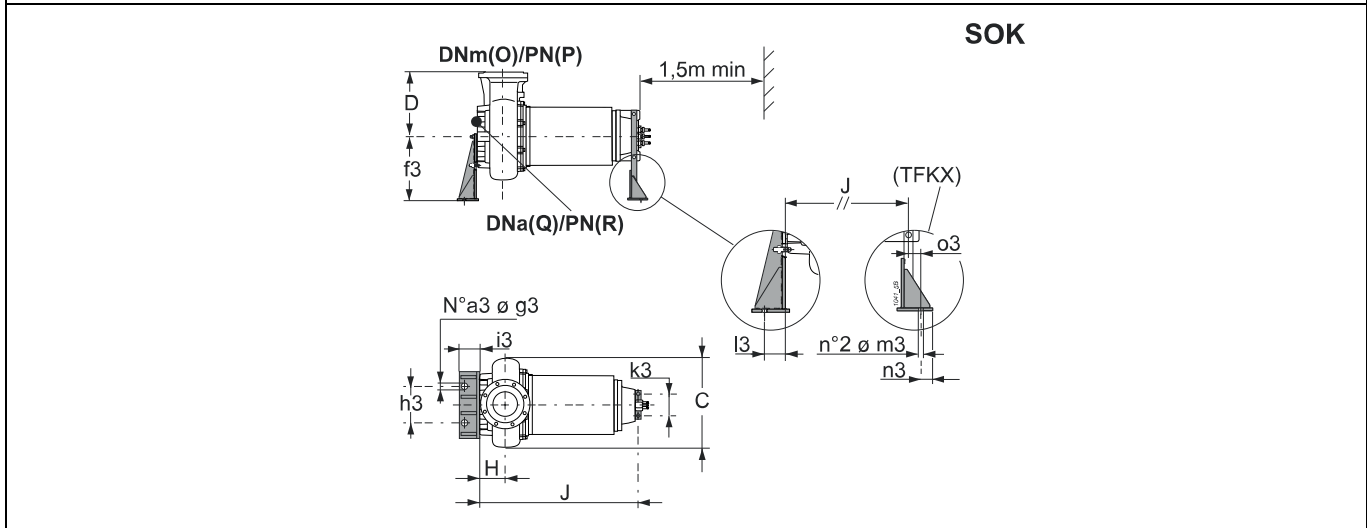

Type Type Tipo	Free passage Passage libre Passaggio Libero	Weight Poids Peso	A	B	C	D	H	J	O	P	Q	R	Accessories Accessoires Accessori								
			[mm]	[kg]	[mm]										BAK.	SOK.	TSK.A				
KCD500VP+145062N1	Ø 72	2790	2766,3	1744,5	1299,5	1120	493	-	500	10	500	10	500/500 3"	-	-						
KCD500VP+145062N1/R	Ø 72	3010	2746,3	1744,5	1299,5	1120	493	2368,3	500	10	500	10	500/500 3"	500	500						
KCD500VL+180062N1	Ø 72	2853	2746,3	1744,5	1299,5	1120	493	-	500	10	500	10	500/500 3"	-	-						
KCD500VL+180062N1/R	Ø 72	3073	2746,3	1744,5	1299,5	1120	493	2368,3	500	10	500	10	500/500 3"	500	500						
KCD500VG+220062N1	Ø 72	3265	2946,3	1744,5	1299,5	1120	493	-	500	10	500	10	500/500 3"	-	-						
KCD500VG+220062N1/R	Ø 72	3525	2946,3	1744,5	1299,5	1120	493	2568,3	500	10	500	10	500/500 3"	500	500						
KCD500VD+275062N1	Ø 72	3445	2946,3	1744,5	1299,5	1120	493	-	500	10	500	10	500/500 3"	-	-						
KCD500VD+275062N1/R	Ø 72	3965	2946,3	1744,5	1299,5	1120	493	2568,3	500	10	500	10	500/500 3"	500	500						
KCD500VA+345062N1	Ø 72	4334	3431,6	1744,5	1299,5	1120	493	-	500	10	500	10	500/500 3"	-	-						
KCD500VA+345062N1/R	Ø 72	4754	3431,6	1744,5	1299,5	1120	493	2998,3	500	10	500	10	500/500 3"	500	500						
BAK.	a	b	c	d	e	f	g	h	i	j	l	m	n	o	p	r	t	u	v	y	z
BAK500/500 3"	157,5	12,5	35	3"	845,7	117	558,8	937,5	375	28	152	1180,7	680	775	57	500	10	400	285	1435	2730
SOK.	a3	f3	g3	h3	i3	k3	l3	m3	n3	o3											
SOK500	3	800	32	740	220	400	100	32	150	35											
TSK.A	a2	b2	c2	d2	e2	f2	g2	h2	i2	j2	k2	n2	w2								
TSK500A	435	762	508	1197	6	26	1400	1500	1050	1415	1570	766	670								

(3) z = Minimum submergence depth for motor without casing with continuous duty S1 (NPSHR permitting)
 y = Minimum submergence depth for motor without casing with intermittent duty S3 (NPSHR permitting)

(3) z = Immersion minimum pour moteur sans chemise en service continu S1 (compatible avec le NPSHR)
 y = Immersion minimum pour moteur sans chemise en service intermittent S3 (compatible avec le NPSHR)

(3) z = Immersion minima per motore senza mantello in funzione continuo S1 compatibilmente con l'NPSHR
 y = Immersione minima con motore senza mantello in funzione intermittente S3 compatibilmente con l'NPSHR

The following are also available: Anchoring bolts, level regulators and Electric panels

Accessoires supplémentaires: Tire-fond, Régulateurs de niveau et coffrets électriques

Sono inoltre disponibili: tirafondi, regolatori di livello e quadri elettrici

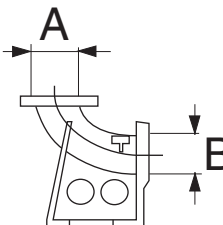
Duck-foot pedestal for automatic coupling (*) <i>Pied d'assise pour accouplement automatique (*)</i> Piede di accoppiamento automatico (*)	Type Type Tipo	A		B		Weight Poids Peso [Kg]	Electric pump type <i>Electropompe type</i> Elettropompa tipo				
		DN	UNI PN	DN	UNI PN		KCM250T	KCD300T	KCD350T	KCD400U	KCD500V
	BAK300/250 3"	300	10	250	10	160	●	-	-	-	-
	BAK350/300 3"	350	10	300	10	230	-	●	-	-	-
	BAK400/400 3"	400	10	400	10	419	-	-	-	●	-
	BAK500/500 3"	500	10	500	10	689	-	-	-	-	●
	BAKS400/350 3"	400	10	350	10	318	-	-	●	-	-

(*) = Complete with:

Pump coupling bracket (nodular cast iron)

Rail pipes anchor bracket (stainless steel)

Screw and nuts

(*) = Composé de:

Support de guidage (fonte à graphite sphéroïdale)

Support de barre de guidage (acier inox)

Visserie

(*) = Completo di:

Staffa corpo premente (ghisa sferoidale)

Staffa per tubi guida (acciaio inox)



Minuteria

Rail pipes (*) (dipped galvanized steel) <i>Barres de guidage (*) (acier galvanisé à chaud)</i> Tubi guida (*) (acciaio zincato a caldo)	Type Type Tipo	Weight Poids Peso [Kg]	Electric pump type <i>Electropompe type</i> Elettropompa tipo				
			KCM250T	KCD300T	KCD350T	KCD400U	KCD500V
	TUB 3"	51	●	●	●	●	●

(*) = On demand: stainless steel

(*) = Sur demande: acier inox

(*) = Su richiesta: acciaio inox

Chain and Shackle Kit (*) <i>Kit Chaîne et manille (*)</i> Kit Catena e Grillo (*)	Type Type Tipo	Max load <i>Portée max</i> Portata max [Kg]	Length <i>Longueur</i> Lunghezza [m]	Electric pump type <i>Electropompe type</i> Elettropompa tipo				
				KCM250T	KCD300T	KCD350T	KCD400U	KCD500V
CAT  GRI 	CAT D.14 / GRL D.16	2500	5	●	●	●	-	-
	CAT D.16 / GRL D.20	4000	5	-	-	-	●	●

(*) = On demand: stainless steel

(*) = Sur demande: acier inox

(*) = Su richiesta: acciaio inox

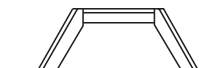
Base frame (dipped galvanized steel) <i>Chassis de soutien (acier galvanisé)</i> Telaio di sostegno (acciaio zincato a caldo)	Type Type Tipo	Weight Poids Peso [Kg]	Electric pump type <i>Electropompe type</i> Elettropompa tipo				
			KCM250T	KCD300T	KCD350T	KCD400U	KCD500V
	TSK350B/R	53	●	●	●	-	-

Flanged hose connection (dipped galvanized steel) <i>Coude pour tuyauterie souple (acier galvanisé à chaud)</i> Curva flangiata portagomma (acciaio zincato a caldo)	Type Type Tipo	Weight Poids Peso [Kg]	Electric pump type <i>Electropompe type</i> Elettropompa tipo				
			KCM250T	KCD300T	KCD350T	KCD400U	KCD500V
	CFP250	51	●	-	-	-	-

Supports (Steel with protective paint) Support de soutien (Acier revêtu de peinture de protection) Supporti (acciaio con vernice protettiva)	Type Type Tipo	Weight Poids Peso	Electric pump type Electropompe type Elettropompa tipo				
		[Kg]	KCM250T	KCD300T	KCD350T	KCD400U	KCD500V
	SOK400	168	-	-	-	145-180-220-260	-
	SOK500	310	-	-	-	-	145-180-220-275-345

Base frame (dipped galvanized steel) Chassis de soutien (acier galvanisé) Telaio di sostegno (acciaio zincato a caldo)	Type Type Tipo	A		B		Weight Poids Peso [Kg]	Electric pump type Electropompe type Elettropompa tipo				
		DN	UNI PN	DN	UNI PN		KCM250T	KCD300T	KCD350T	KCD400U	KCD500V
	TSK250A/R	250	10	250	10	101	●	-	-	-	-
	TSK300A/R	300	10	300	10	116	-	●	-	-	-
	TSK350A/R	350	10	350	10	128	-	-	●	-	-
	TSK400A	400	10	400	10	253	-	-	-	●	-
	TSK500A	500	10	500	10	0	-	-	-	-	●

(*) = Fixed installation in a dry chamber

(*) = Installation fixe en fosse

(*) = Esecuzione per camera asciutta

Flanged elbow (dipped galvanized steel) Coude bridé (acier galvanisé à chaud) Curva flangiata (acciaio zincato a caldo)	Type Type Tipo	A		B		Weight Poids Peso [Kg]	Electric pump type Electropompe type Elettropompa tipo				
		DN	UNI PN	DN	UNI PN		KCM250T	KCD300T	KCD350T	KCD400U	KCD500V
	CFK250	250	10	250	10	43,5	●	-	-	-	-
	CFK300	300	10	300	10	62	-	●	-	-	-
	CFK350	350	10	350	10	87,5	-	-	●	-	-
	CFK400	400	10	400	10	0	-	-	-	●	-
	CFK500	500	10	500	10	0	-	-	-	-	●

50 Hz motor features (*N/X)
Caractéristiques des moteurs à 50 Hz (*N/X)
Caratteristiche motori a 50 Hz (*N/X)

Poles Pôles Poli	Motor type Moteur type Motore tipo	Motor power Puiss. moteur Potenza motore		Absorption Intensité Assorbimento	Direct starting Démarrage direct Avviamento diretto	Direct starting2 Démarrage direct2 Avviamento diretto2		Starts / hour max Max démarrages / heure Max avviamenti/ora	Degree of intermittence Degré d'intermittence Grado di intermittenza
		P ₁	P ₂	IN (400V)		(Standard)			
		[kW]		[A]		I _S /I _N	Direct Direct Diretto		
6	KC06006..T280..	64,6	60	108,4	7,4	●	●	8	-
	KC08206..T315..	86,6	82	144,6	7	●	●	8	-
	KC10006..T315..	105	100	172,3	7,2	●	●	8	-
	KC14506..U315..	154,26	145	235	6,6	●	●	6	-
	KC14506..V315..	152,4	145	262	5,12	●	●	10	-
	KC18006..U315..	189,47	180	280	6,3	●	●	6	-
	KC18006..V315..	189,7	180	347	5,7	●	●	10	-
	KC22006..U315..	231,58	220	375	6,8	●	●	6	-
	KC22006..V315..	231,78	220	412	6,64	●	●	10	-
	KC26006..U315..	273,68	260	465	6,8	●	●	6	-
	KC27506..V315..	286,95	275	498	6	●	●	10	-
	KC34506..V355..	368	345	595	6,21	●	●	10	-
4	KC09004..T280..	95,2	90	153,6	7,6	●	●	8	-
	KC10004..T280..	105,8	100	170,7	6,9	●	●	8	-
	KC12004..T315..	126,3	120	204,9	7,4	●	●	8	-
	KC14504..T315..	146,5	145	247,3	7,3	●	●	8	-
	KC18004..T315..	187,7	180	304,5	7,2	●	●	8	-

*N = Standard version

*X = Explosion-proof version

P₁ = Power absorbed by the motor

P₂ = Power rated by the motor

I_N = Rated current

I_S = Starting current

- The electric pumps are suitable for S1 continuous service with submersed motor and for S3 intermittent service (see relative degrees of intermittence in the table) with non-submersed motor.

S3 service stands for intermittent service consisting of 10 minute equal cycles of which the previous table indicates the minutes of the cycle during which the motor may operate (eg. : S3 = 25% operation consists of a repetitive sequence of 2,5 minutes operation and 7,5 minutes at a standstill). See standard CEI EN 60034-1.

- The electric motors are produced in the following voltage ratings: 400 V ± 10% standard; 230 V ± 10% on request.

Other voltages on request.

*N = Version standard

*X = Version antidéflagrante

P₁ = Puissance absorbée par le moteur

P₂ = Puissance restituée par le moteur

I_N = Intensité nominale

I_S = Intensité au démarrage

- L'électropompe est apte à fonctionner en service continu S1 avec le moteur complètement immergé, en service intermittent S3 moteur non immergé (se reporter aux valeurs d'intermittence mentionnées dans le tableau).

Le service S3 indique un fonctionnement intermittent par cycles identiques de 10 minutes. Le tableau ci-dessus indique le temps de marche du moteur en minutes pour 1 cycle de 10 minutes (Ex. : S3 = 25% chaque cycle sera composé de 2,5 minutes de marche et de 7,5 minutes d'arrêt). Voir norme CEI EN 60034-1.

- Les moteurs électriques prévus doivent être alimentés aux tensions nominales suivantes: 400 V ± 10% standard; 230 V ± 10% sur demande.

Tensions différentes sur demande.

*N = Versione standard

*X = Versione antideflagrante

P₁ = Potenza assorbita motore

P₂ = Potenza resa dal motore

I_N = Corrente nominale

I_S = Corrente di avviamento

- Le elettropompe sono atte a funzionare in servizio continuo S1 con motore immerso, in servizio intermittente S3 con motore non immerso (vedi relativi gradi di intermittenza nella tabella).

Il servizio S3 sta ad indicare un funzionamento intermittente composto da cicli tutti uguali di 10 minuti di cui si indicano i minuti del ciclo in cui il motore può funzionare (Es. : S3 = 25% il funzionamento è composto da una sequenza ripetitiva di 2,5 minuti di funzionamento e di 7,5 minuti di sosta). Vedi norma CEI EN 60034-1.

- I motori elettrici sono previsti per essere alimentati alle seguenti tensioni nominali di rete: 400 V ± 10% standard; 230 V ± 10% a richiesta.

Tensioni diverse su richiesta.

Flanges (UNI EN 1092-2)
 Brides (UNI EN 1092-2)
 Flange (UNI EN 1092-2)

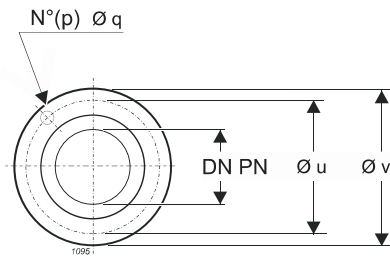

per K.M100N_4 poli: DNm=DN100-PN16 øq=M16
 for K.M100N_4 poles: DNm=DN100-PN16 øq=M16

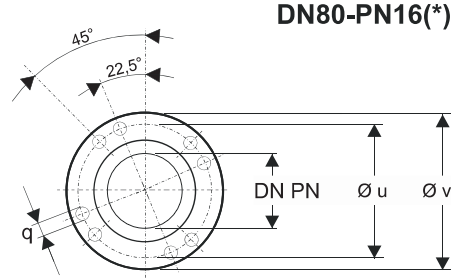

n°4 fori DN80 PN16 + n°4 fori ex DN80 PN10
 n°4 holes DN80 PN16 + n°4 holes ex DN80 PN10

Port ø Ø Orifice Ø Bocca	Holes Trous Fori		Ø u	Ø v
	p	q DNa - q DNm		
DN [mm] - PN [bar]	N°	Ø [mm]	[mm]	
DN65 - PN16	4	(-) - 18	145	185
DN65 - PN16 (*)	4	M16 - (-)	145	185
DN80 - ex PN10	4	(-) - 18	160	200
DN80 - PN16	8	(-) - 18	160	200
DN80 - PN16 (*)	4	M16 - (-)	160	200
DN100 - PN16	8	(-) - 18	180	220
DN100 - PN16	8	M16 - (-)	180	220
DN100 - PN16 (*)	4	M16 - (-)	180	220
DN150 - PN16	8	(-) - 22	240	285
DN150 - PN16	8	M20 - (-)	240	285
DN150 - PN16 (*)	4	M20 - (-)	240	285
DN200 - PN10	8	M20 - 22	295	340
DN250 - PN10	12	M20 - 22	350	395
DN300 - PN10	12	M20 - 22	400	445
DN350 - PN10	16	M20 - 22	460	505
DN400 - PN10	8	(M24) - (-)	515	565
DN400 - PN10	16	(-) - 26	515	565
DN500 - PN10	8	(M24) - (-)	620	670
DN500 - PN10	20	(-) - 26	620	670

caprari

The dimensions have an indicative value. Executive drawing will be supplied on request upon order.
CAPRARI S.p.A. reserves the right to make changes to improve its products at any time and without any notice

*Les dimensions sont fournies à titre indicatif. Le plan bon pour exécution sera fourni sur demande au moment de la commande.
CAPRARI S.p.A. se réserve la faculté d'apporter des modifications visant à améliorer ses propres produits à tout moment et sans aucun préavis.*

**Le dimensioni hanno valore indicativo. Il disegno esecutivo sarà fornito su richiesta in fase d'ordine.
CAPRARI S.p.A. si riserva facoltà di apportare modifiche atte a migliorare i propri prodotti in qualsiasi momento e senza preavviso alcuno.**