

**SUBMERSIBLE
DRAINAGE AND
WASTEWATER
PUMPS**

caprari



D-M SERIES



MORE THAN 200 MODELS FOR ALL APPLICATIONS



MS

MX

MG



DA

DX-DW

DR

**FAST
DELIVERY
WITHIN
48H**

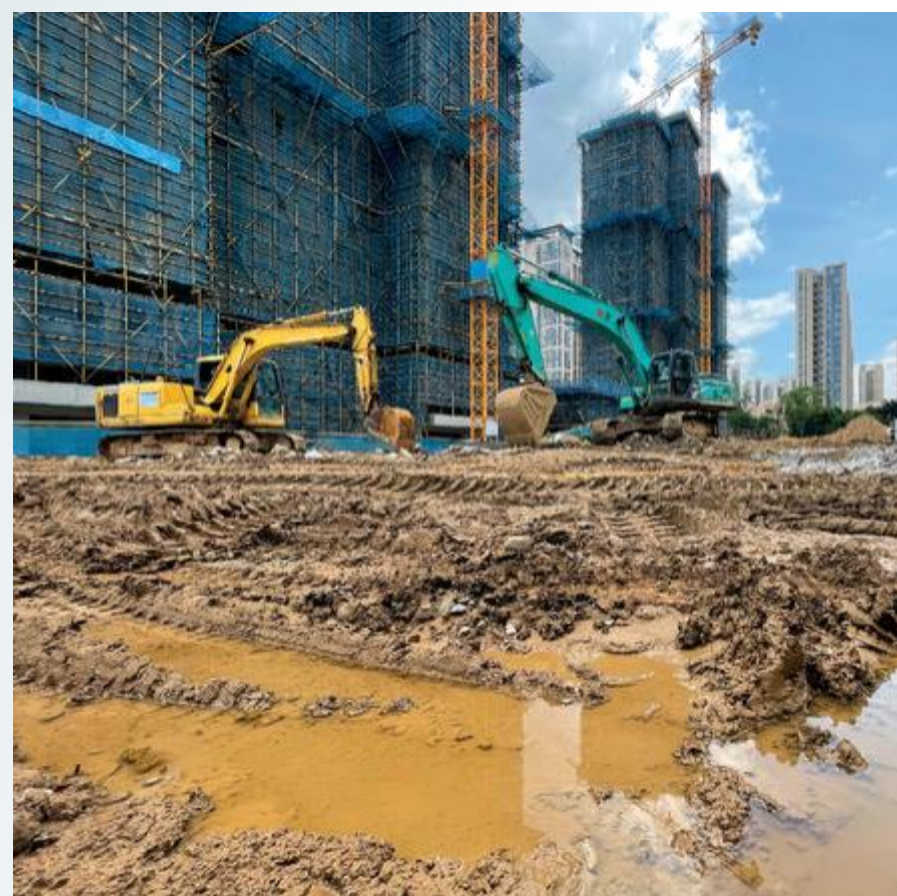

SERIE D-M

IDEAL FOR

DRAINAGE - SUPPLIERS

CONSTRUCTION

INDUSTRIAL MACHINERY RENTAL

WASTEWATER

LARGE AREAS

SERIE D-M

IDEAL FOR

DRAINAGE – SUPPLIERS | WATER INDUSTRY



SERIE D-M

IDEAL FOR

CONSTRUCTION COMPANIES

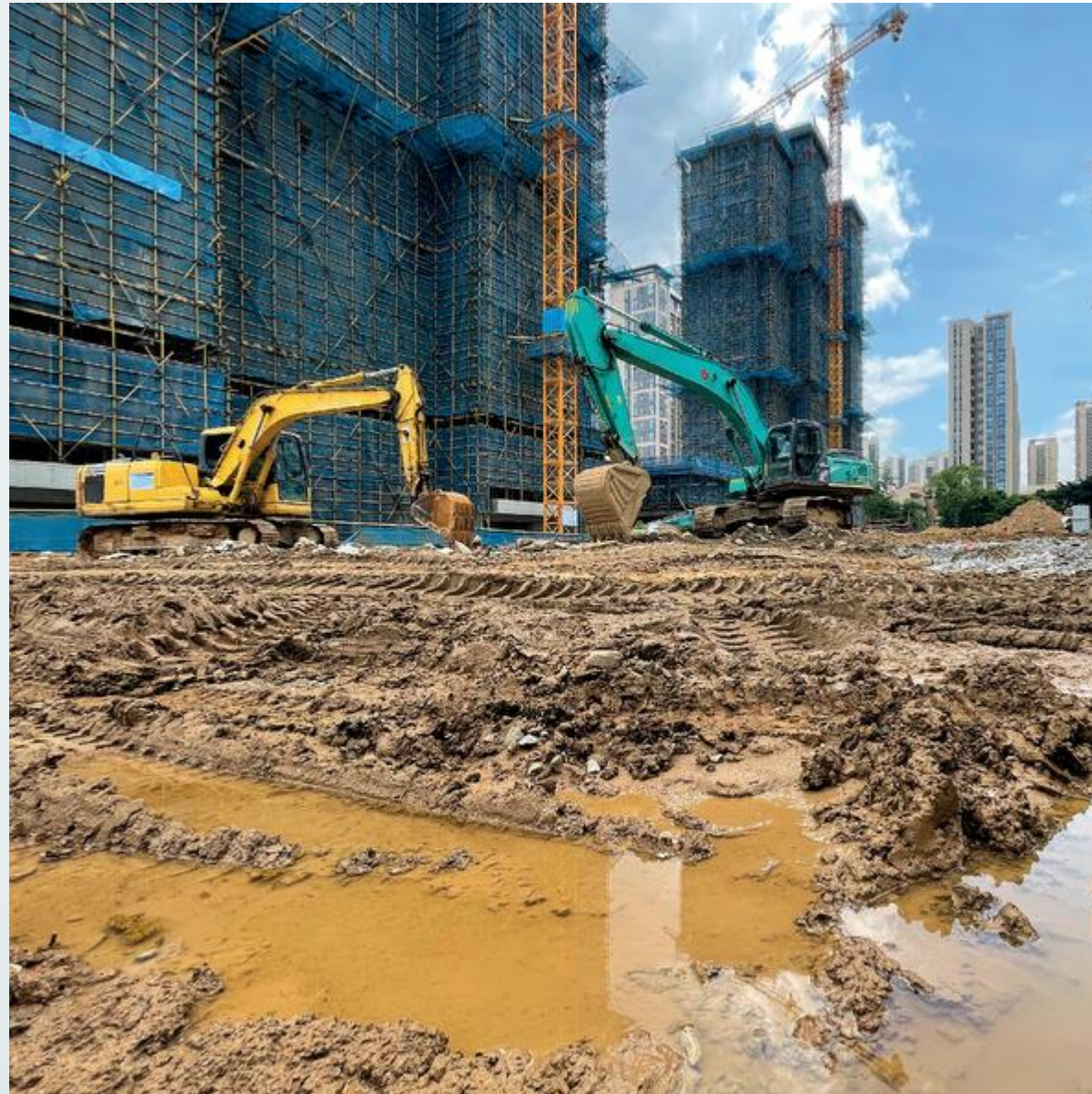

SERIE D-M

IDEAL FOR

INDUSTRIAL MACHINERY HIRE - LARGE AREAS



M

STURDY AND RELIABLE

Single-impeller submersible pumps ideal for lifting domestic, industrial and residential wastewater containing solids. The large open passages ensure reliability and durability, even under heavy-duty conditions. The compactness of the pump ensures maximum reliability and ease of installation.

TECHNICAL FEATURES

Impeller types: vortex (W), double-channel (D), single-channel (M) or shredder (T)

- Materials: cast iron and stainless steel
- Supply voltage:
 - 50Hz - 230V±10% single-phase
 - 230V, 400V±10% three-phase
 - 60Hz - 220V±10% single-phase
 - 220V, 380V±10% three-phase
- Protection degree: IP68
- Insulation class: F
- Power supply cable: H07RN-F
- Maximum liquid temperature: 35 °C

EXECUTIONS UPON REQUEST

- Motor suitable for frequency converter
- Other voltages
- Cable length up to 20m
- Other types of mechanical seals



EASY TO INSTALL

Installation types

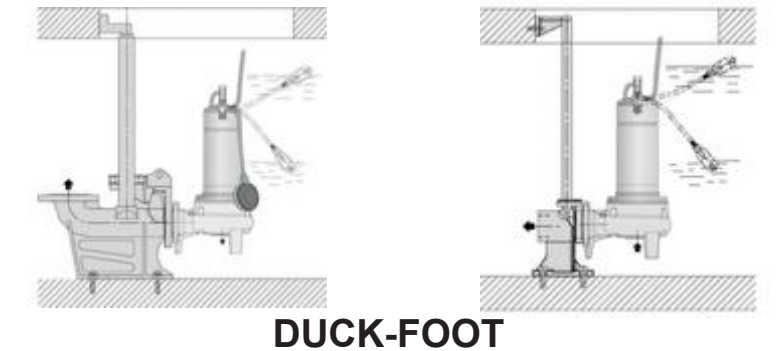
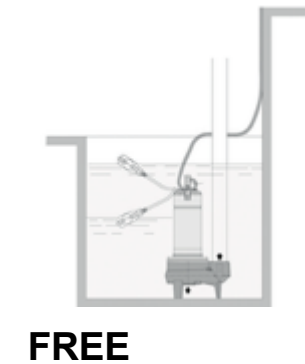

**THE BEST
VALUE FOR
MONEY ON
THE MARKET**

M

STURDY AND RELIABLE

WHY CHOOSE M SERIES

1 INSTALLATION FLEXIBILITY

- Horizontal flanged/threaded delivery port for coupling foot
- Vertical threaded delivery port for free installation

2 MAXIMUM PROTECTION

- Double mechanical seal with interposed oil chamber
- Relief valve for proper priming of the pump

3 ROBUSTNESS AND RELIABILITY

- Impeller and pump casing with cataphoresis treatment
- High component thickness and stainless steel shaft

4 VERSATILITY

- Version with/without float switch for starting and stopping the pump
- Single-phase execution with integrated capacitor designed for easy inspection



caprari

**FAST
DELIVERY**

**ECONOMIC
COMPETITIVENESS**

**WIDE
RANGE**

M

MS

STURDY AND RELIABLE

Stainless steel/cast iron pumps with:

- Double mechanical seal
- Vortex, double channel or shredder impeller
- Vertical delivery threaded flange or horizontal with threaded delivery flange
- Cable length: 10 m
- Single-phase models with float

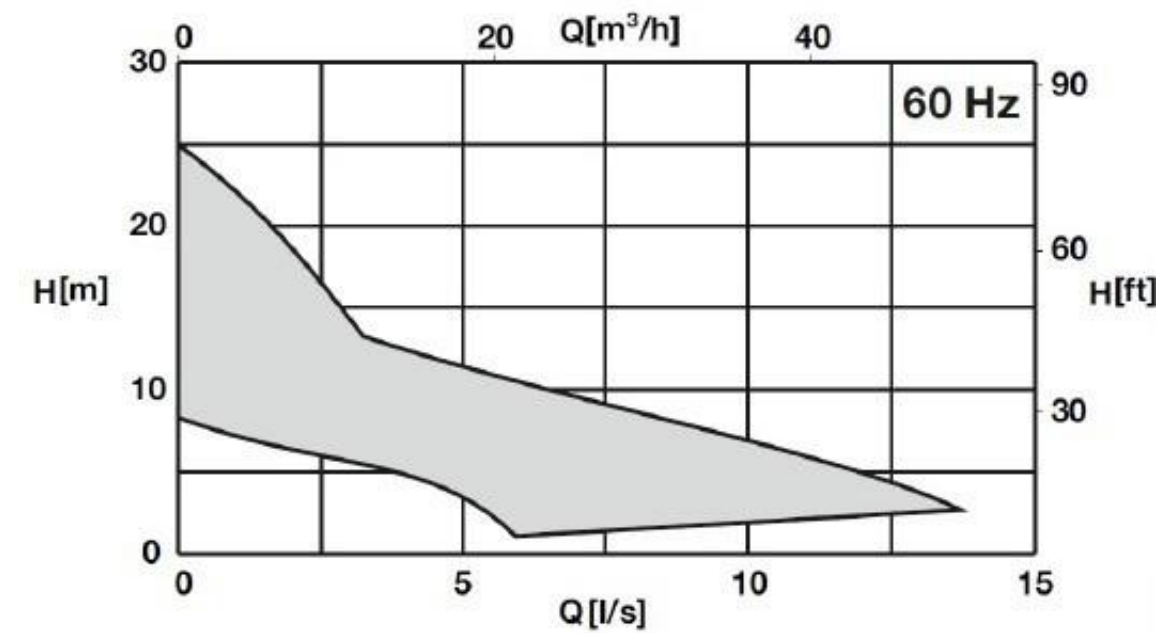
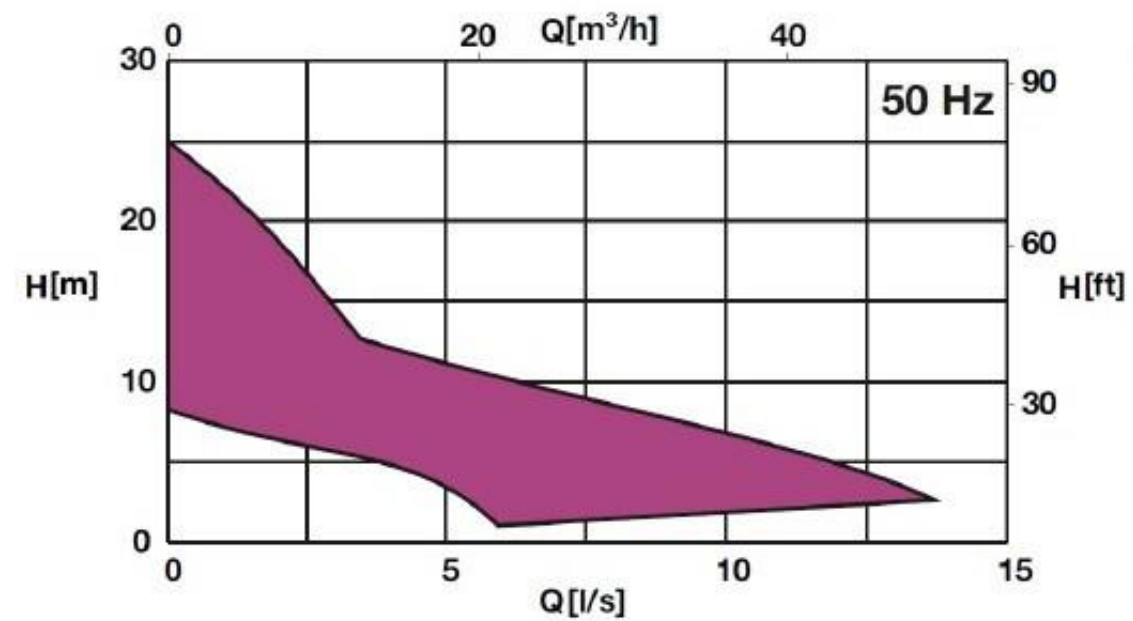

caprari

M

MG

STURDY AND RELIABLE

Cast iron pumps with:

- Double mechanical seal
- Vortex or single-channel impeller
- Vertical delivery threaded flange or horizontal flange
- Cable length: 10 m
- Single-phase models with float

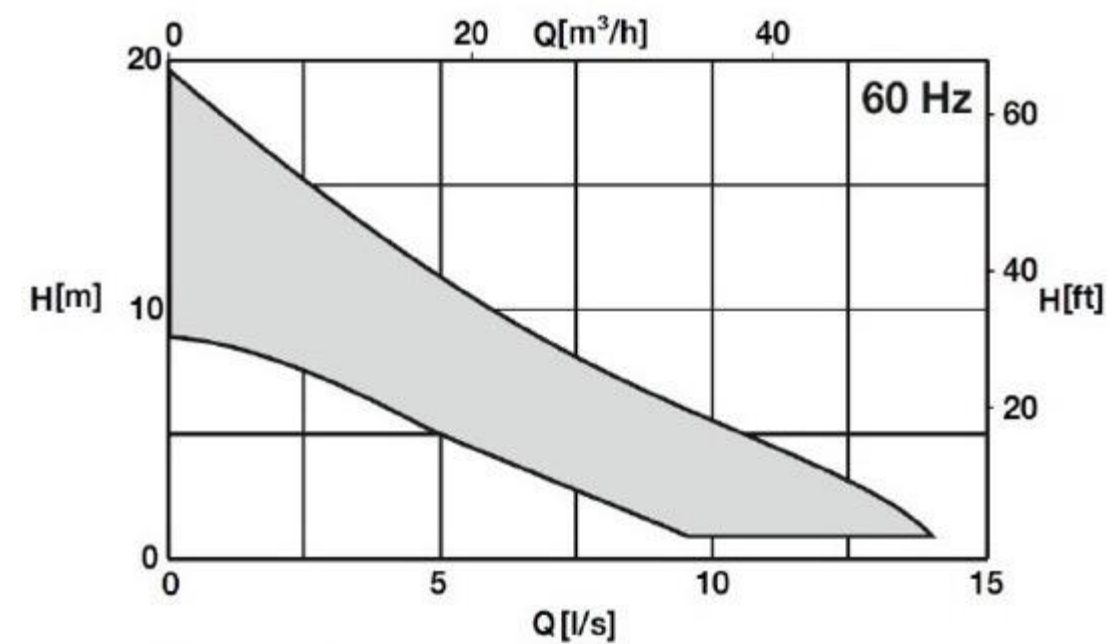
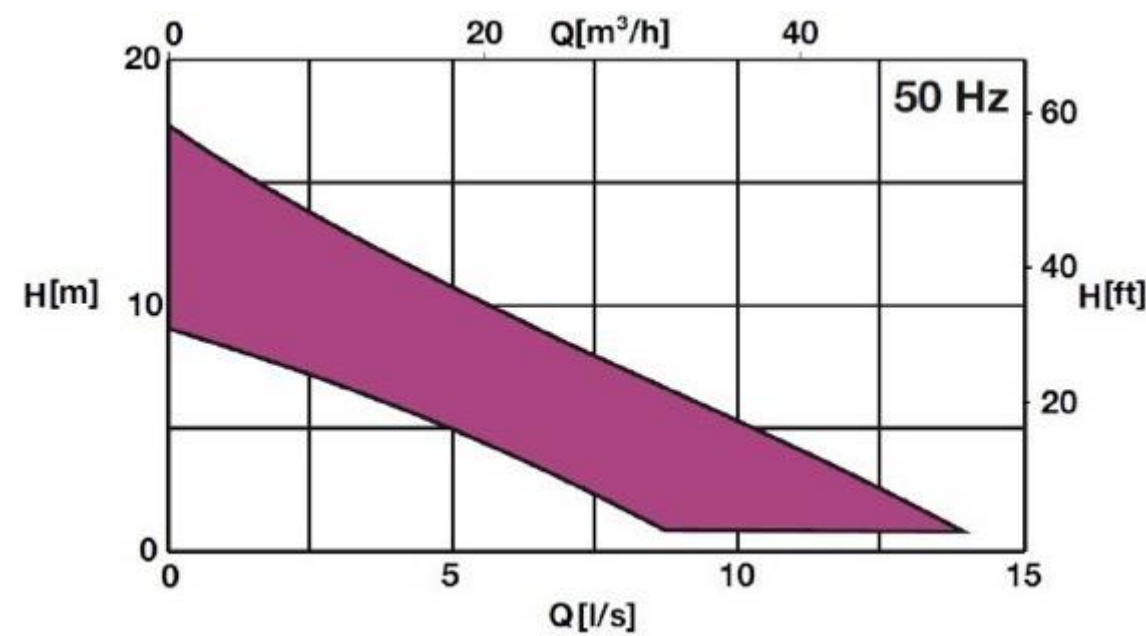

caprari

M

MX

STURDY AND RELIABLE

Stainless steel pumps with:

- Double mechanical seal
- Vortex or double channel impeller
- Vertical delivery threaded
- Cable length: 10 m
- Single-phase models with float

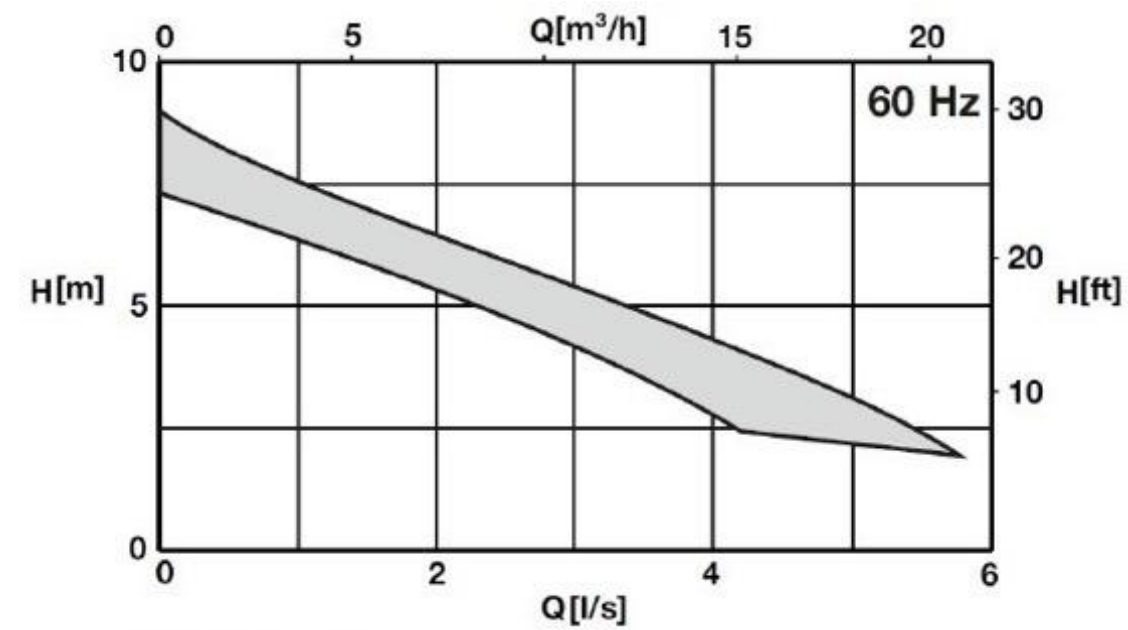
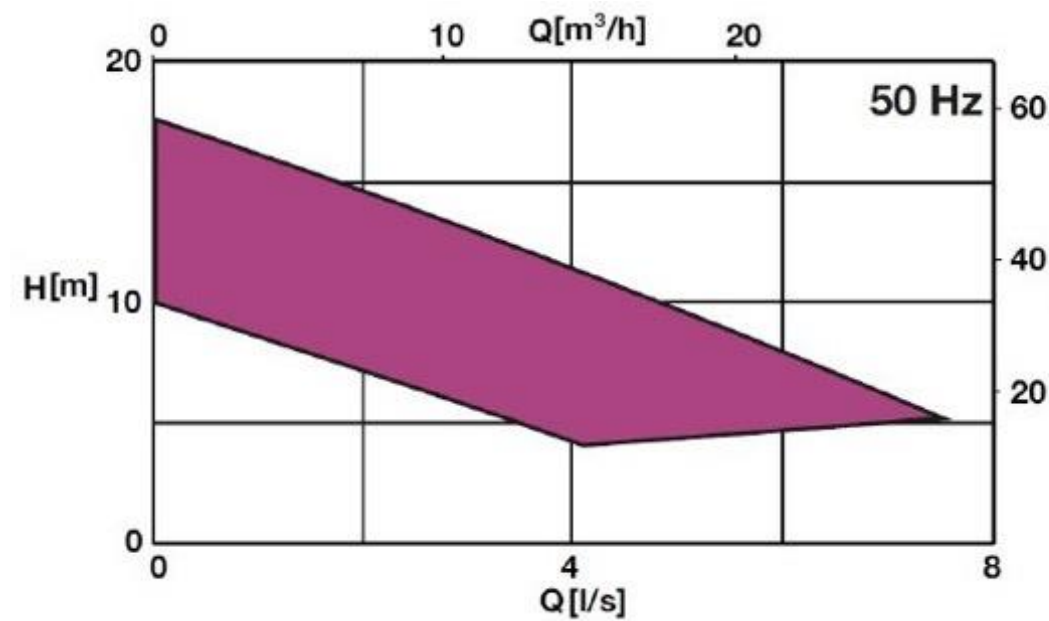

caprari

D

LIGHT AND EASY TO HANDLE

Single-impeller submersible pumps for drainage of clean water with suspended solids.

Ideal for domestic, professional and construction site use. Its design and quality materials ensure robustness and ease of transport and use

TECHNICAL FEATURES

- Single-impeller submersible pumps with vortex (W), open (R) or centrifugal (C) impeller
- Materials: noryl, cast iron and stainless steel
- Supply voltage:
 - 50Hz - 230V±10% single-phase
 - 230V, 400V±10% three-phase
 - 60Hz - 220V±10% single-phase
 - 220V, 380V±10% three-phase
- Protection degree: IP68
- Insulation class: F
- Power supply cable: H05RN-F or H07RN-F
- Maximum liquid temperature:
 - 35°C for DM.R and DA.R
 - 40°C for DR.R
 - 50°C for DX.R, DX.W and DW.W

EXECUTIONS UPON REQUEST

- Motor suitable for frequency converter
- Other voltages
- Cable length up to 20m
- Other types of mechanical seals



EASY TO INSTALL

Installation types

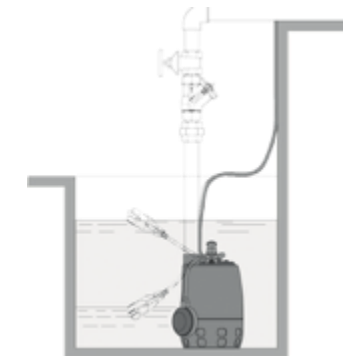

FREE

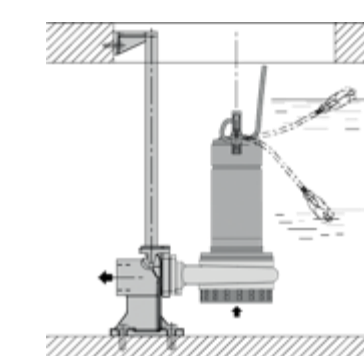
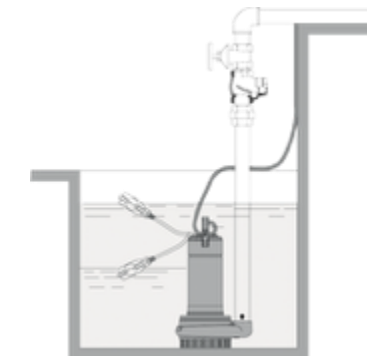

COUPLING FOOT

**THE BEST
VALUE FOR
MONEY ON
THE MARKET**

D

LIGHT AND EASY TO HANDLE

WHY CHOOSE D SERIES



1 INSTALLATION FLEXIBILITY

- Vertical threaded delivery port for free installation
- Propylene handle for easy handling

2 MAXIMUM PROTECTION

- Double mechanical seal with interposed oil chamber
- Suction strainer with double row of holes to prevent clogging

3 ROBUSTNESS AND RELIABILITY

- Stainless steel impeller, jacket and shaft
- Motor cooled by liquid pumped between jacket and motor

4 VERSATILITY

- Version with/without float switch for starting and stopping the pump
- Single-phase execution with integrated capacitor designed for easy inspection

**FAST
DELIVERY**

**ECONOMIC
COMPETITIVENESS**

**WIDE
RANGE**

caprari

D

DX

LIGHT AND EASY TO HANDLE

AISI 304/316 stainless steel pumps with:

- Mechanical seal
- Vortex or centrifugal impeller
- Vertical threaded outlet
- Cable length: 5 m
- Single-phase models with float

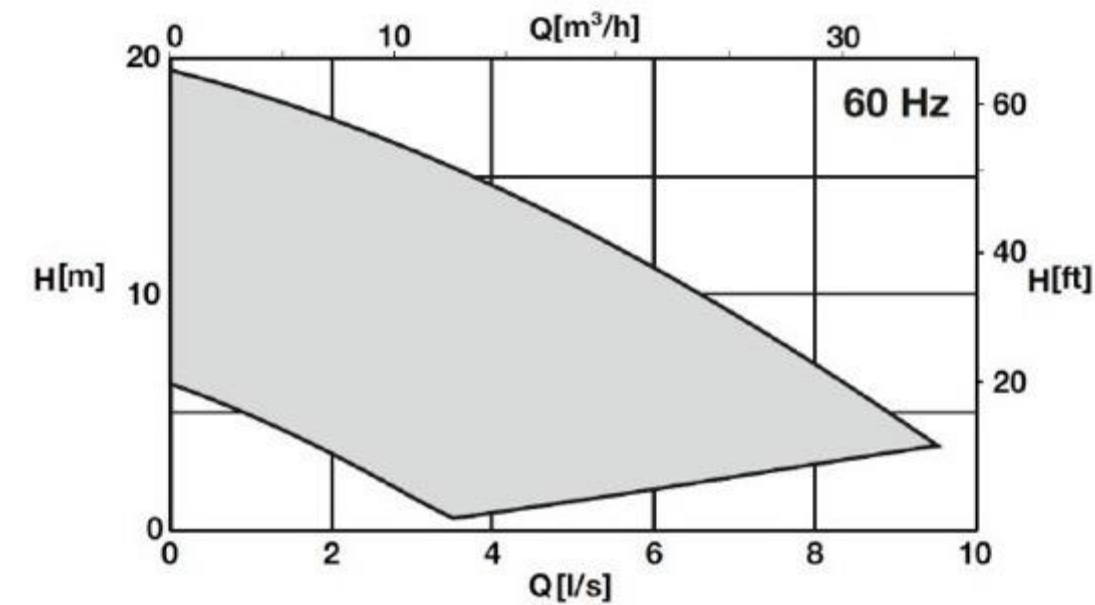
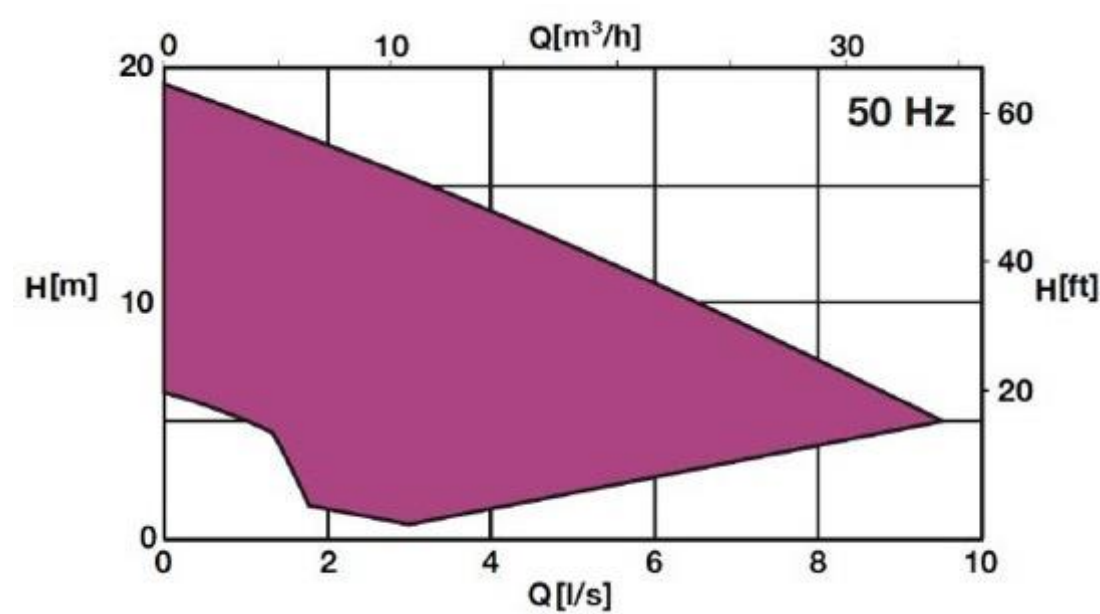

caprari

D

LIGHT AND EASY TO HANDLE

DM/DA

Stainless steel/cast iron/plastic pumps with:

- Double mechanical seal
- Centrifugal impeller
- Vertical delivery thread or horizontal flange
- Cable length: 10 m
- Single-phase models with float

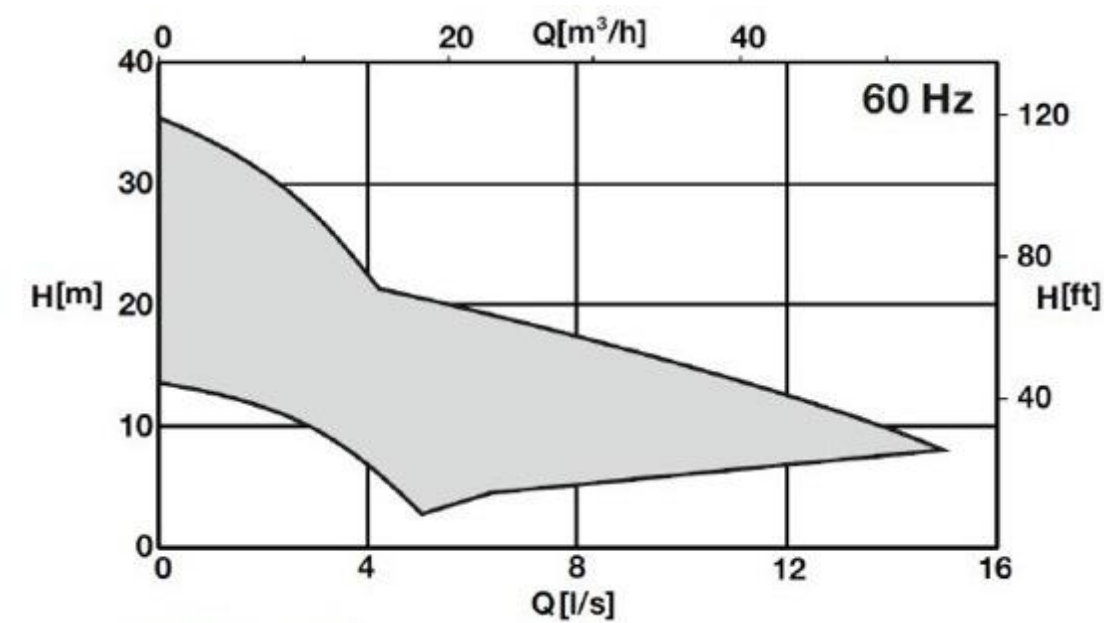
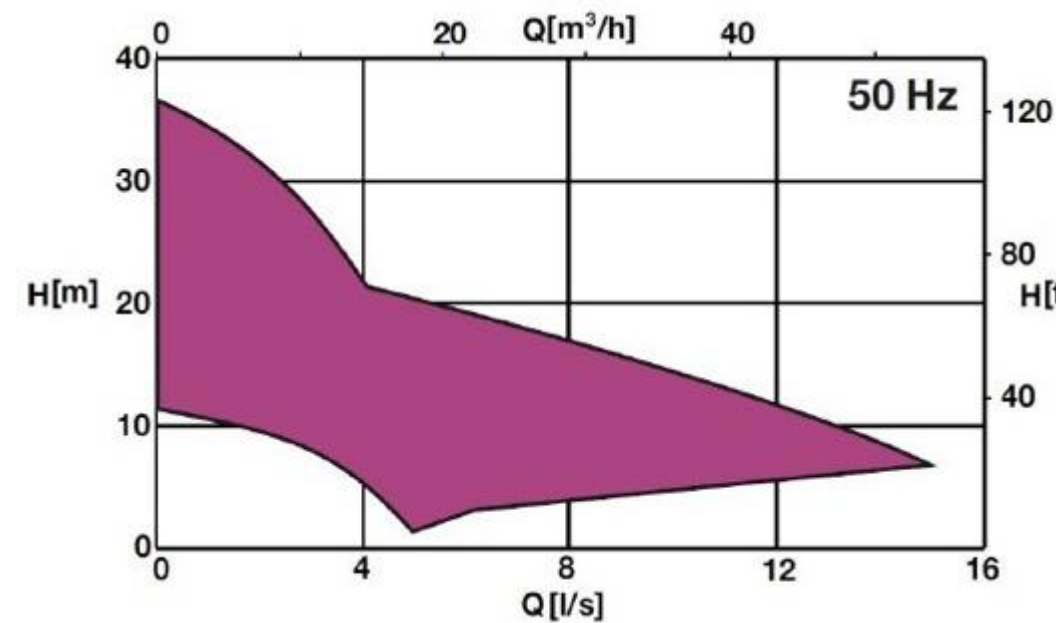

caprari

D

DR

LIGHT AND EASY TO HANDLE

Single-impeller cast iron/aluminium pumps with:

- Double mechanical seal
- Vortex impeller
- Delivery with pipe connection
- Cable length: 10 m

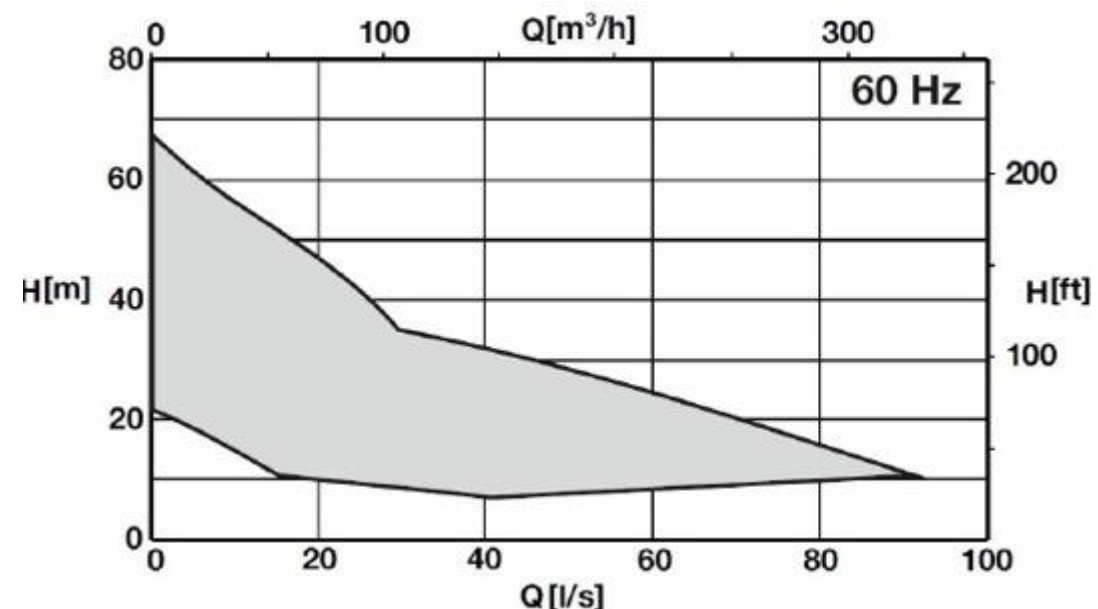
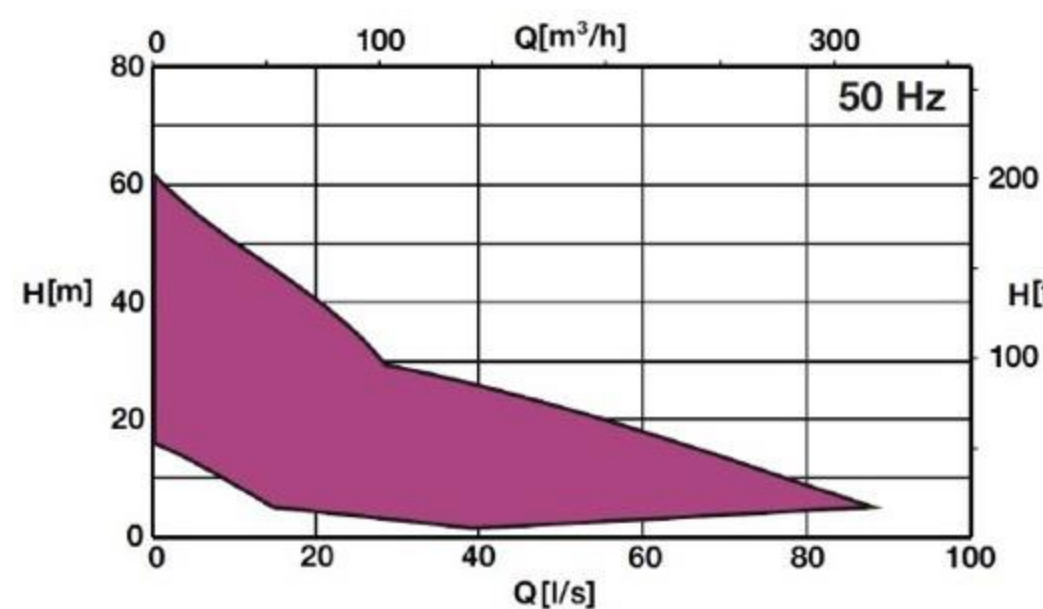

caprari

global presence local operation

Caprari's customer-centric approach drives the development of high-quality products, services, and tailored solutions. Supported by a global network of subsidiaries, specialized partners, and distributors, we deliver efficient and professional service, meeting our customers' needs at every stage—from design to after-sales support.

To further empower our customers and partners, we offer specialized training through the Caprari Training Centre in Modena, as well as the PumpPro Academy. This comprehensive digital platform provides 24/7 access to learning resources, ensuring continuous development and expertise in water management solutions.

caprari



**fast
deliveries
worldwide**



**original
spare parts
always available**



**specialist
training
at the training
centre and
online**



**repairs and
maintenance
on site and in
the workshop**

caprari

www.caprari.com