

caprari

product range

index

our group	04
capability to respond to any requirement	06
exclusive technical consultancy	08
we make a difference in every project	10
certified quality	14
a complete range	16
exclusive systems and patents	18
submersible pumps and motors	20
surface pumps	34
electric motors	44
firefighting Pumps	46
waste water pumps and systems	48
control and monitoring systems	56
global presence, local service	60

our group



Water is not negotiable

Caprari brings decades of expertise in designing and manufacturing efficient, sustainable water pumping solutions. With a global footprint and a deep understanding of diverse customer needs, we are uniquely positioned to anticipate and respond to challenges in water management.

Our extensive range of fully MADE IN ITALY products embodies flexibility, innovation, and exceptional quality. This dedication ensures our solutions are tailored to meet the highest standards of performance and sustainability.

Wateralia, a strategic industrial holding company formed in 2021 through the collaboration of Caprari and Ambienta – one of Europe's leading asset managers dedicated to environmental sustainability – is committed to providing innovative solutions for the responsible management of water resources.



capability to respond to any requirement

Caprari specializes in developing advanced water pumping solutions for a diverse range of sectors and applications. From initial product design through to rigorous testing, we deliver a comprehensive service that ensures the highest standards of performance and reliability.

This commitment to excellence has earned us the trust of organizations worldwide, including government bodies, private enterprises, OEMs, and engineering firms.

Our objective is to build enduring partnerships founded on mutual satisfaction and trust, fostering shared growth and success with our customers across the globe.



aqueducts and waste water management

- Treatment of drinking water, domestic and industrial wastewater
- Extraction from deep wells
- Distribution and pressurization
- Water purification and desalination



infrastructure

- Rainwater recovery and discharge
- Water drainage from excavations
- Waste water management and treatment
- Pressurization and fire prevention



irrigation

- Groundwater withdrawal
- Large irrigation systems
- Land reclamation
- Greenhouse and frost protection irrigation



industry, OEM and offshore

- Process auxiliary services
- Artificial snow-making
- Dust suppression systems in quarries
- Sea water application

exclusive technical consultancy

Caprari offers a premium technical consultancy service, delivering end-to-end solutions throughout every stage of a project. From initial study and analysis to prototyping, production, commissioning, and after-sales support, we ensure our customers receive expert guidance at every step.

Our dedicated and highly skilled Application Engineering team conducts in-depth feasibility studies for bespoke and specialized applications. They provide prompt, reliable feedback on heavy-duty products and address the technical complexities of even the most demanding tender specifications. This comprehensive approach underscores our commitment to delivering tailored solutions that meet the highest standards of performance and reliability.



creation of customized solutions

- High flow rate
- High pressure
- Design variations



definition of special metallurgies

- Bronze
- Aluminium Bronze
- Stainless Steel
- Duplex
- Super-duplex

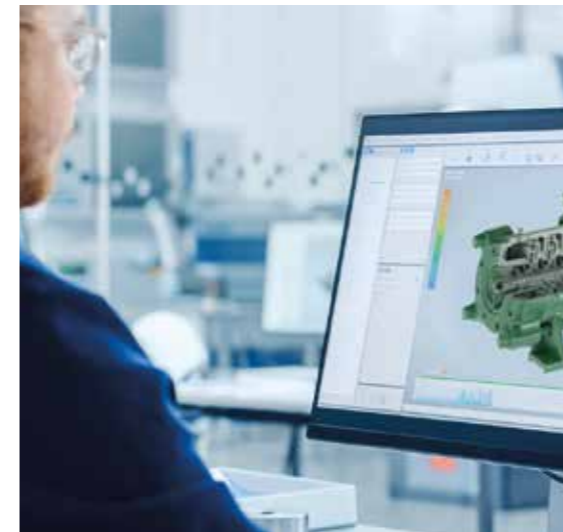

heavy duty applications consultancy

- High temperature of pumped liquid
- High solids content in water
- Inshore and offshore marine applications
- Booster submergence



control and command panel supply

- Custom electromechanical and electronic control panels
- IoT monitoring for predictive maintenance
- Sensors
- Remote control

we make a difference in every project

Caprari is the ideal partner for OEMs, offering tailored solutions based on your specific needs. From simple configurations to fully customized projects, we guarantee the quality and reliability that define us.

Customized solutions

Different materials for different applications

The selection of different materials is tailored to the operating conditions and specific requirements of the application. With the support of our experts, you will find the ideal solution, ensuring optimal performance and long-lasting durability.

CASING	IMPELLER	MEC. SEAL	SHAFT	WEAR RING
				
CAST IRON	CAST IRON	SILICON CARBIDE	AISI 303	EPDM
		-----	-----	-----
BRONZE	BRONZE	CERAMIC	AISI 304 / 304L	NBR AND
		-----	-----	-----
CASTED / STAMPED SS AISI 304 AND AISI 316	CASTED / STAMPED SS AISI 304 AND AISI 316	GRAPHITE	AISI 316 / 316L	HNBR
		-----	-----	-----
DUPLEX SUPER-DUPLEX	DUPLEX SUPER-DUPLEX	WIDIA	AISI 420 / 420B	AISI 304
			AISI 430 / 430F	AISI 316
			AISI 431	BRONZE
			AISI 630	CAST IRON
			DUPLEX SUPER-DUPLEX	

Impeller diameter optimization

We offer the possibility to customize the impeller diameter to optimize the pump's performance curve, adapting it to the customer's required operating point.

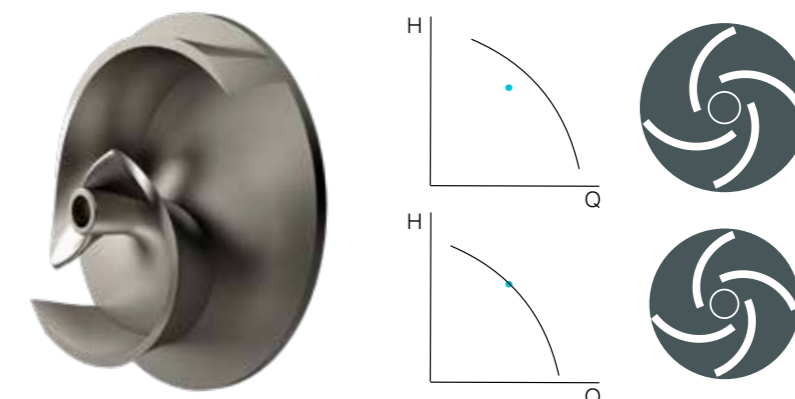

Customized solutions

Wide motor range

The widest range of surface and submersible motors, with multiple voltages and customization options to ensure optimal performance in every application.

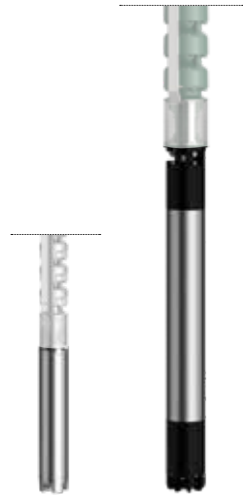

Borehole pumps

- Power from 4 to 440kW
- 2/4 poles
- Low and medium supply voltage
- Water filled, canned and permanent magnet versions (efficiency above 90%)
- VSD and hot water configurations

Example of customizations

- Glycol at 50%
- PT100 thermal probes
- Reinforced motor connections
- Dedicated supply voltage and cable length



Surface and VTP pumps

- Power from 0,37 to 3.000kW
- 2/4/6/8 poles
- Low and medium supply voltage
- IE4 / IE3 / IE2 efficiency class
- Horizontal and vertical configuration

- Dedicated supply voltage
- Insulated bearing for VSD application
- Various insulation and efficiency class
- Tropicalisation



Wastewater pumps

- Power from 1,1 to 345kW
- 2/4/6/8 poles
- Low voltage supply
- IE3 efficiency class

- PT100 thermal probes
- SiC-SiC mechanical seals
- Dedicated supply voltage and insulation class
- Cable motor with other length or shielded version

high-resistance coatings

Caprari guarantees reliable products by improving resistance to corrosion, abrasion and wear thanks to ceramic coatings that offer excellent chemical protection, greater operational reliability and enable wear control for preventive maintenance. The pumps, classified ISO C4-H, are suitable for industrial and coastal environments and allow scheduled maintenance intervals to be extended to 15 up to 25 years.



Properties

Surface preparation in accordance with standards (ISO 8501: Sa 2.5) prior to treatment

High resistance to high temperatures and mechanical wear

High chemical resistance

Protective barrier and smooth surfaces

Benefits

Extended pump service life

Increased operational safety

Improved performance

Protection against corrosion and erosion

Durable and eco-friendly

Available in MATERIALS

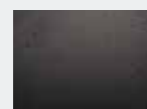

Cast iron



Bronze



Stainless Steel



Duplex



Super-Duplex

certified quality

At Caprari, quality is embedded in every stage of our process, from design to final delivery. Our commitment is upheld by our dedicated Quality Centers, four state-of-the-art Testing Rooms, and a CTF (Customer Testing Facility) certified and managed by a specialized team.

We are equally committed to sustainability and the protection of human health. All Caprari products comply with the RoHS directive and REACH regulations, including rigorous PFAS content control, ensuring our solutions meet the highest environmental and safety standards.



System certifications



Product certifications



state-of-the-art testing facility

advanced measurement tools ensure every new project meets the highest reliability standards.



testing on request

every product can undergo hydraulic performance testing to confirm compliance with specifications.



submersible motors: 100% end of line testing

to guarantee excellent performance



training and support

multiple support programs available

a complete range

Caprari offers the widest range of products and most efficient water supply solutions, from deep well extraction, wastewater lifting and drainage, to water supply and distribution in residential, industrial and irrigation areas, to firefighting, with a variety of products for all conceivable water treatment applications.



water collection and distribution



boosting and distribution of surface water



firefighting pumps



wastewater transport and treatment



pump control technology

exclusive systems and patents

Advanced solutions designed to improve performance, reduce maintenance and ensure maximum reliability in all operating conditions.



DRYWET
Oil cooling system allowing the use of a single pump in submerged or dry pit installations

CAPRARI INTERNATIONAL PATENT



FIXING SYSTEM
Ultra-fast adjustment system for impeller ensuring installation and maintenance in less than a minute

CAPRARI INTERNATIONAL PATENT

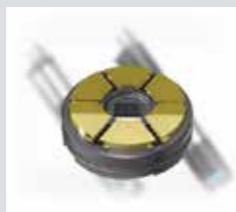

HT BEARING
High-strength bearing ensuring extreme reliability when subjected to high axial thrusts

CAPRARI INTERNATIONAL PATENT



DEFENDER
Corrosion protection accelerating passivation and extending the service life of stainless steel components

CAPRARI INTERNATIONAL PATENT



SAND-OUT SYSTEM
Exclusive system guaranteeing reliability and safe starting even in the presence of large quantities of sand

CAPRARI INTERNATIONAL PATENT



CONDUCTIVITY PROBE
Immediate water infiltration protection in the oil chamber to protect the electrical components including the ATEX version

CAPRARI INTERNATIONAL PATENT



SMART-FIX SYSTEM
A fastening system for the valve-pump casing which is resistant to high pressures over 70 bar

CAPRARI INTERNATIONAL PATENT



K+ NON STOP
Exclusive system with four combined effects for continuous operation in wastewater



MOTOR PROTECTOR
Device to protect the pump-motor coupling and the mechanical seal of the motor against sand



C PLUS
Motor with reinforced insulation, ideal for applications with frequency converters and high temperatures

The widest range of 4" ÷ 22" borehole electric pumps and motors to satisfy all your needs: ideal for water supply, irrigation, water industry, sea water applications and desalination.
The design and innovative patented solutions ensure reliability and durability over time.
The coupling with Caprari submersible motors guarantees benchmark performance and maximum energy saving.

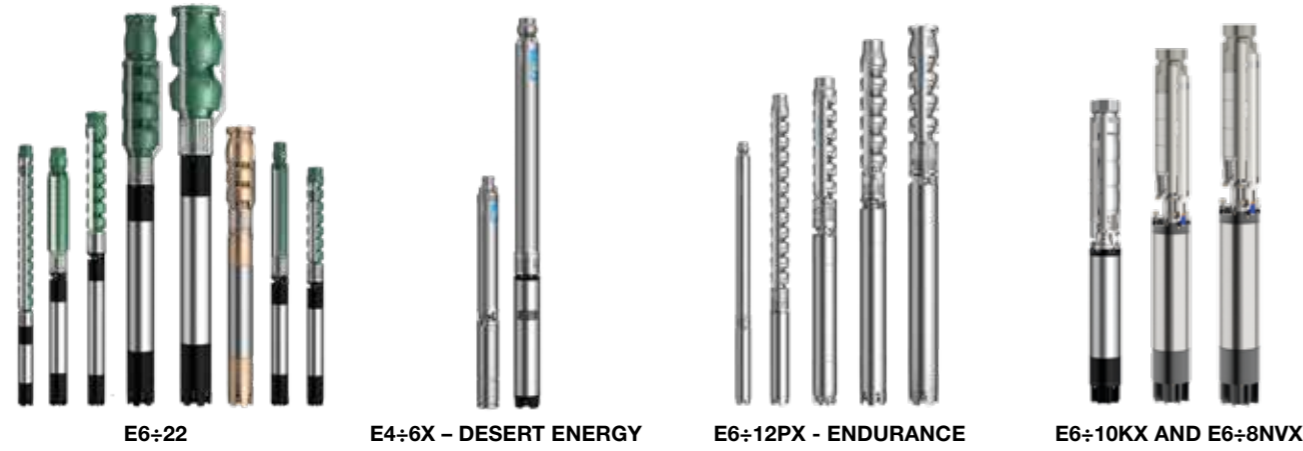

One solution for all application

MATERIALS

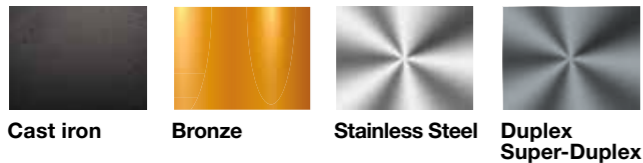

Certifications



PERFORMANCE DATA

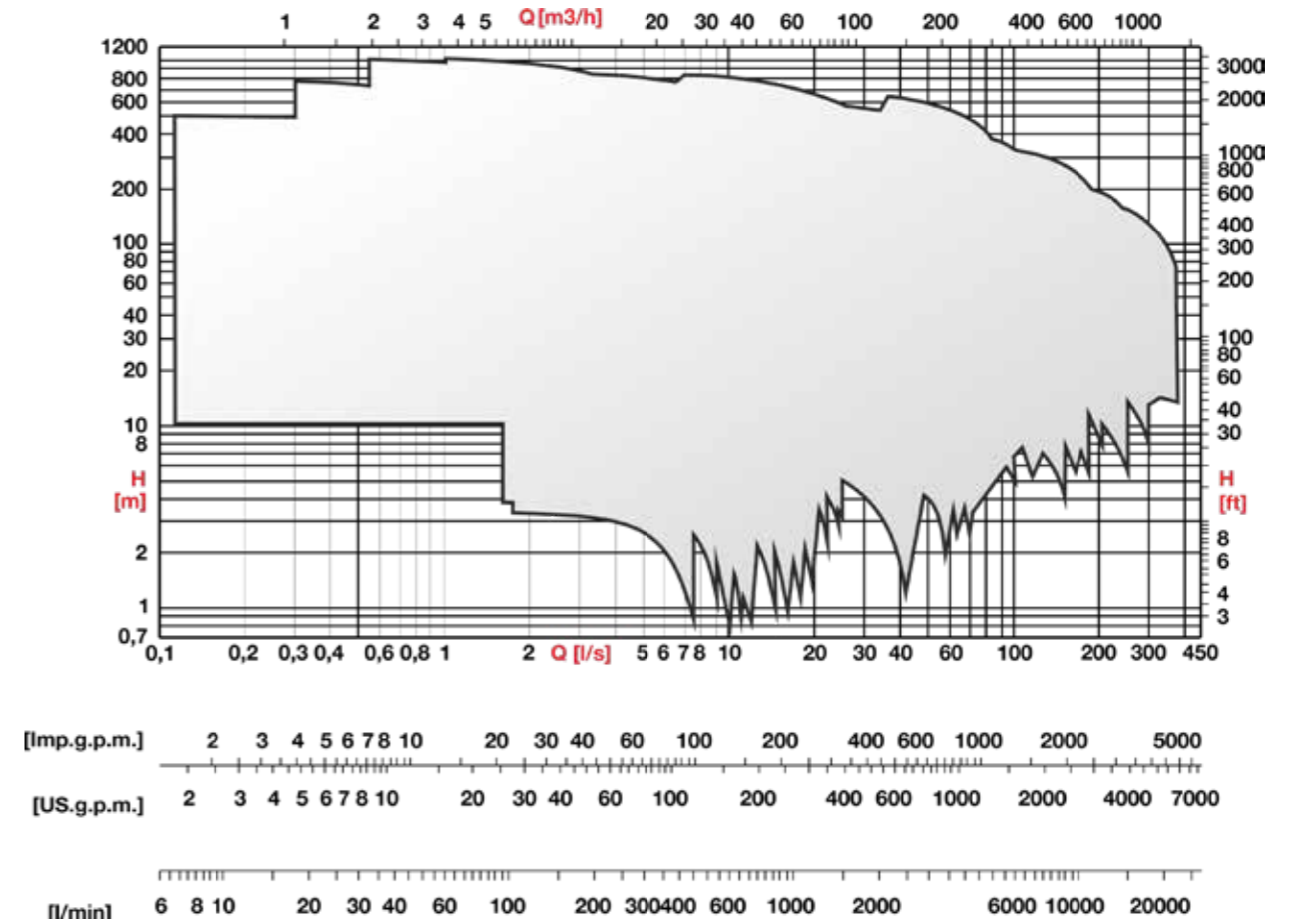

Series		E6 ÷ 22	E4 - 6X	E6 ÷ 12PX	E6 - 8NVX	E6 ÷ 10KX
Pump Ø [inches]		6" ÷ 22"	4" - 6"	6" ÷ 12"	6" - 8"	6" ÷ 10"
Max. power [kW]		440	45	440	110	150
Max. flow rate [l/s]	50 Hz	350	12	190	37	73
	60 Hz	420	12	190	42	74
Max. head [m]	50 Hz	700	700	850	440	450
	60 Hz	650	550	730	460	450

Series	MAC6 ÷ 14	MMP6 ÷ 10	MPC6 ÷ 10	MC4
Motor Ø [inches]	6" ÷ 14"	6" ÷ 10"	6" ÷ 10"	4"
Power [kW]	4 ÷ 440	4 ÷ 250	4 ÷ 150	0,37 ÷ 7,5
Frequency	50-60	100-120	50-60	50-60
No. of poles	2 - 4	4	2	2
Connection type	NEMA 6-8 PROPRIETARY	NEMA 6-8	NEMA 6-8	NEMA 4
Type	ASYNCHRONOUS REWINDABLE WATER FILLED	SYNCHRONOUS PERMANENT MAGNETS REWINDABLE WATER FILLED	ASYNCHRONOUS REWINDABLE WATER FILLED	ASYNCHRONOUS REWINDABLE OIL FILLED
Inverter use	●	●	●	●
High-temperature windings	●	●	●	●
Supply voltage	LOW MEDIUM	LOW	LOW	LOW

Innovation and reliability



HIGH QUALITY CASTINGS

- High thicknesses of casted components
- Smooth surfaces and optimized hydraulic profiles without weldings

EXTREME PERFORMANCE BEARING BUSHES AND WEAR RINGS

- High efficiency and sand protection
- Easy maintenance: faster bearing disassembly

HIGH PROTECTION SUCTION CASING

- Extreme protection of coupling area from direct contact with the liquid
- Longer life: high precision casting



DEFENDER ANTICORROSION DEVICE

- A safety barrier against galvanic currents and electrochemical corrosion
- It protects cast iron components from graphitisation and speeds up the passivation of stainless steel components



SAND-OUT SYSTEM

- The wear ring system ensures long life and reliable operation even when the pumped fluid contains large amounts of sand and solids, up to 450g/m³
- It also provides a reliable starting surge, thereby avoiding maintenance



SMART-FIX SYSTEM

- The valve casing-pump fastening system guarantees reliability with pressure up to 70bar
- Maximum reliability also in heavy applications

CAPRARI INTERNATIONAL PATENT



MOTOR PROTECTOR: ANTISAND DEVICE

- Operating safety: protection of coupling area and mechanical seal
- Extreme abrasion resistance

HIGH QUALITY SiC/SiC MECHANICAL SEAL

- Maximum reliability: electric part protected from liquid entry
- The best solution against sand, temperature shocks and chemicals

CPLUS: HEAVY DUTY APPLICATION MOTOR

- The best solution for hot water and VSD applications
- Double insulation windings in PE2+PA



MEDIUM VOLTAGE UP TO 3.300V

- The best solution in heavy-duty, high-power applications that require high efficiency, reliability and excellent control



PERMANENT MAGNET MOTORS

- The most efficient solution to ensure the maximum energy saving: $\eta > 90\%$
- 6-8-10" sizes with power up to 250kW



HT BEARING

- Maximum resistance to axial thrusts up to 70.000N, 3 times higher than traditional devices
- Simplicity and reliability: unique innovative design with reduced number of components

CAPRARI INTERNATIONAL PATENT

E6÷22

Borehole pumps in cast iron

The wide range of 6÷22" pumps guarantees benchmark performance with efficiency above 80%. The historic Caprari submersible pumps to ensure maximum reliability and durability over time.

TECHNICAL SPECIFICATIONS AND ADVANTAGES

- High versatility: cast iron, bronze, stainless steel, duplex and super-duplex
- Efficiency >80%
- 2/4 poles
- Power up to 440kW
- Coupling: NEMA 6 – 8 Standard, Caprari proprietary and shaft-key
- Vertical/Horizontal installation
- Booster version for dry chamber installation



PERFORMANCE DATA

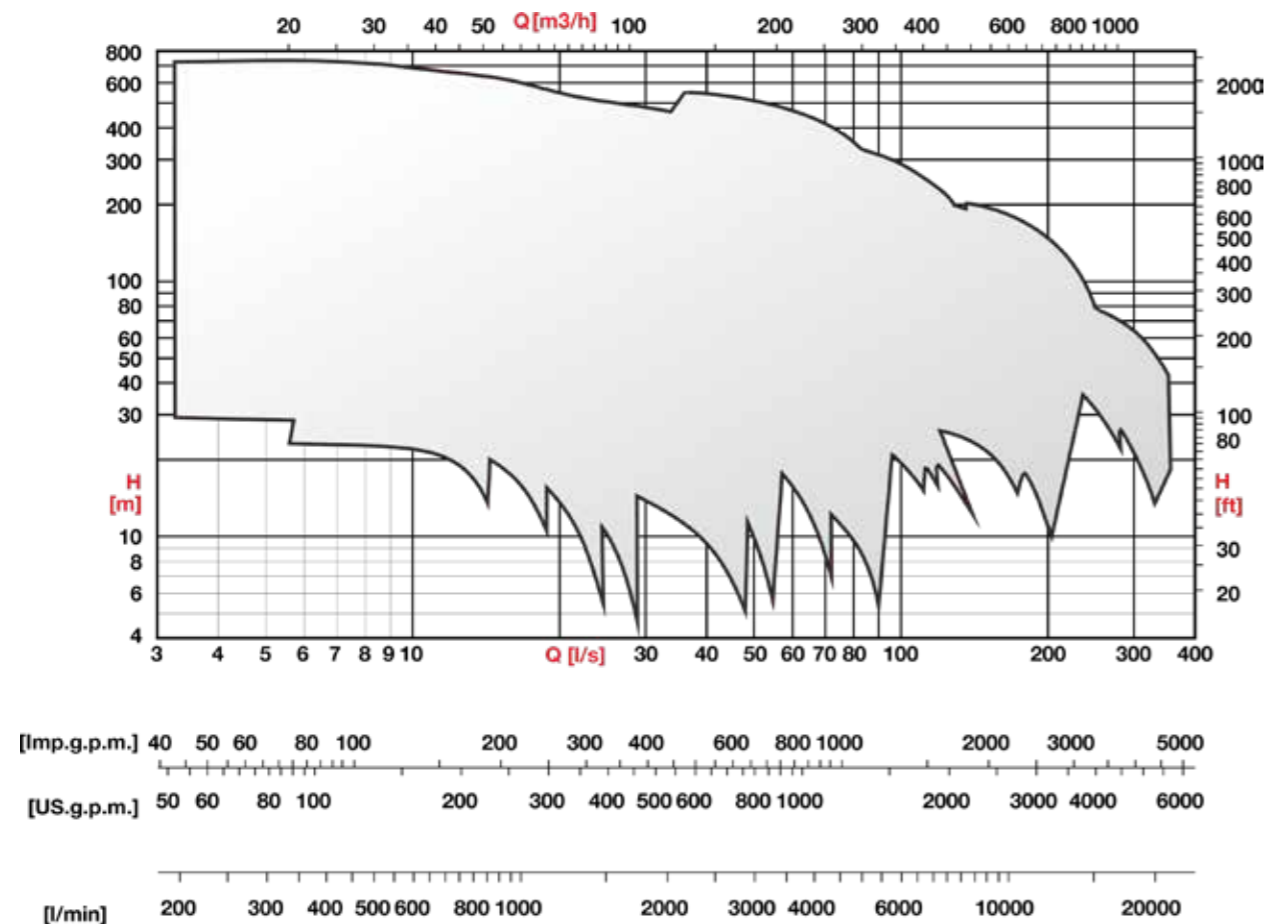

CERTIFICATIONS



E6÷12PX - ENDURANCE

Borehole pumps in high precision casted stainless steel

The ENDURANCE range of 6÷12" pumps is ideal for applications with sea water, aggressive liquids and high sand contents. The series is designed to guarantee the best performance even in extreme conditions.



TECHNICAL SPECIFICATIONS AND ADVANTAGES

- Maximum resistance: AISI 316 stainless steel, duplex and super-duplex
- Efficiency >80%
- 2/4 poles
- Power up to 440kW
- Coupling: NEMA 6 – 8 Standard, Caprari proprietary and shaft-key
- Vertical/Horizontal installation
- Booster version for dry chamber installation

MAXIMUM RESISTANCE AGAINST CORROSION AND ABRASION

- Quality of materials
- No weldings
- High thickness of the components



HIGH ENERGY SAVING

- Smooth surfaces
- Efficiency over 80%
- Optimized impellers on the duty point

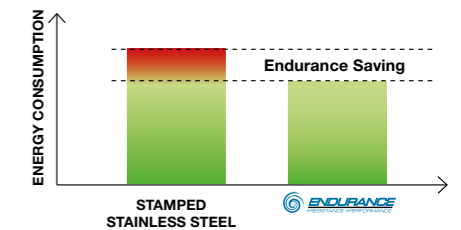

PERFORMANCE DATA

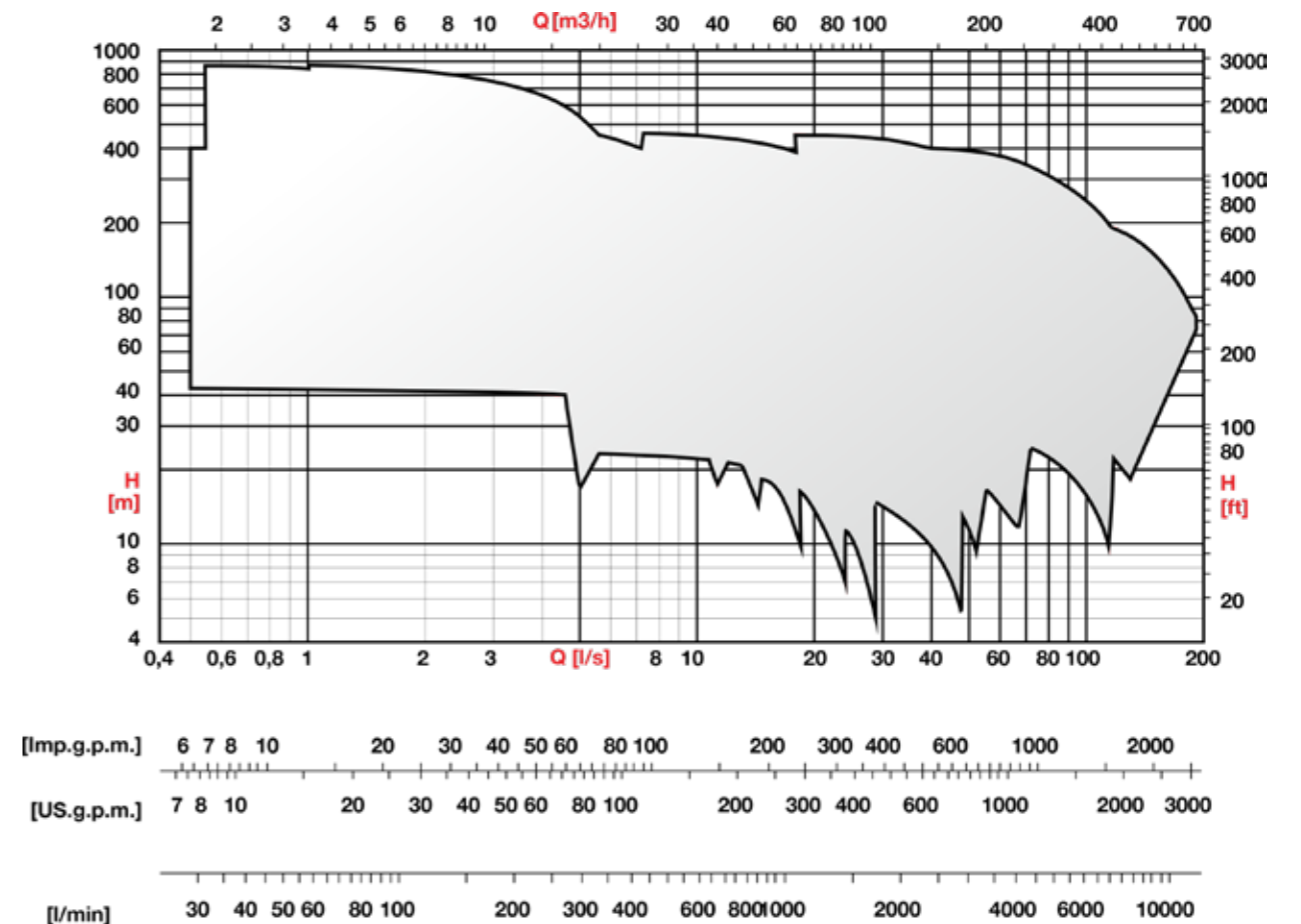

CERTIFICATIONS



E4÷6X – DESERT ENERGY

Borehole pumps in stainless steel and technopolymer

The DESERT ENERGY range of 4" and 6" is the best choice for liquid with high concentration of sand up to 450g/m³. The best performance on the market and the innovative patented solutions ensure reliability and durability over time. Ideal for small and medium sized wells in irrigation.

TECHNICAL SPECIFICATIONS AND ADVANTAGES

- Impellers and diffuser in reinforced technopolymer
- Suction casing in high precision casted stainless steel: maximum reliability
- Efficiency >75%
- Power up to 45kW
- Coupling: NEMA 4 - 6 Standard
- Vertical/Horizontal installation



PERFORMANCE DATA

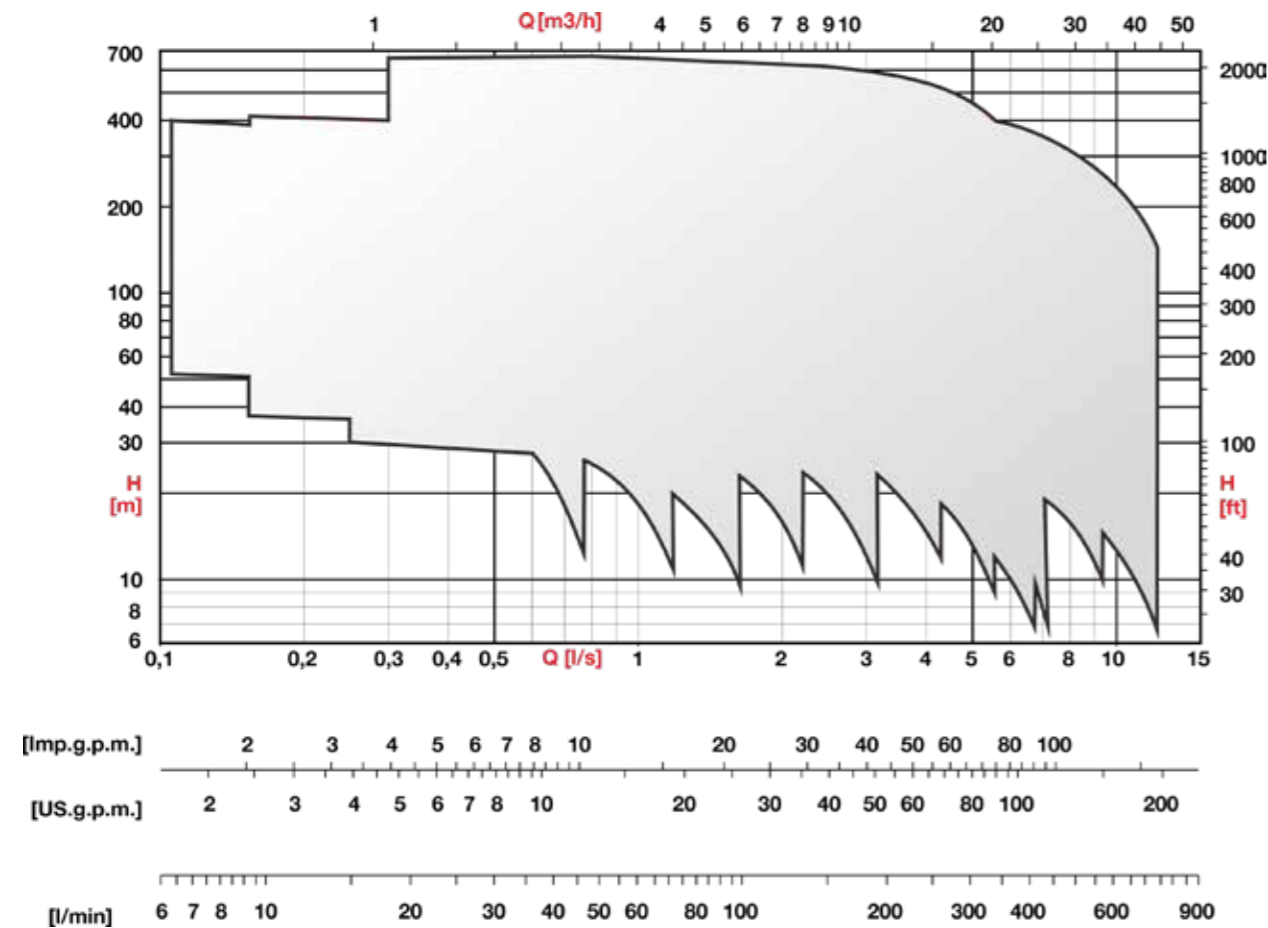

CERTIFICATIONS



E6÷10KX | E6÷8NVX

Borehole pumps in stamped stainless steel

The 6"-8"-10" AISI 304 and AISI 316 stainless steel range: robustness, reliability and Caprari quality of at a competitive price.

TECHNICAL SPECIFICATIONS AND ADVANTAGES

- Two different Caprari factories: Italy (E.NVX) and Turkey (E.KX)
- Impeller and diffusers in stamped stainless steel
- Valve and suction casing in high precision casted stainless steel: maximum reliability
- Efficiency >74%
- Power up to 150kW
- Coupling: NEMA 4 – 6 – 8 Standard
- Vertical/Horizontal installation
- Booster version for dry chamber installation



PERFORMANCE DATA

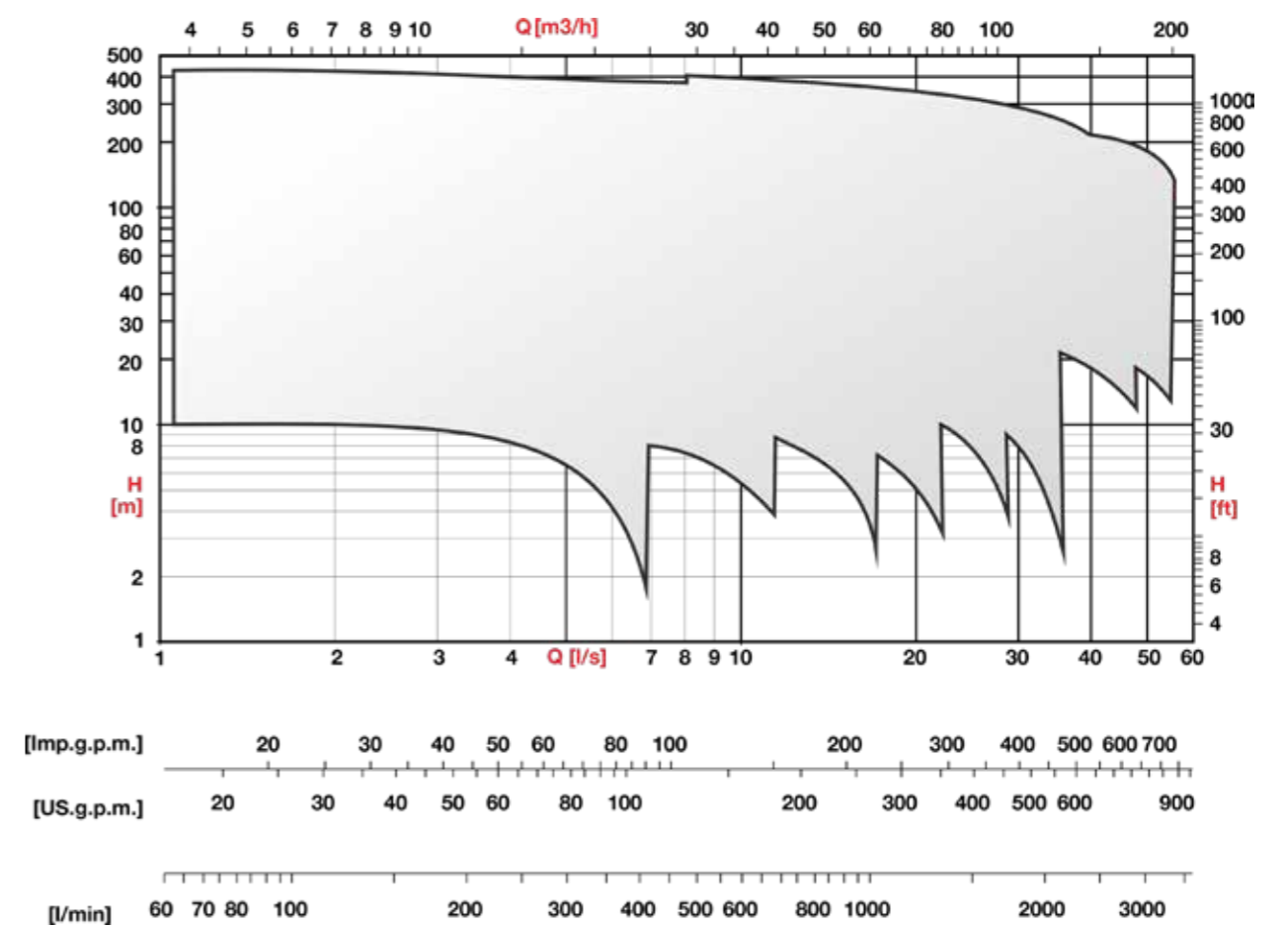

CERTIFICATIONS



MAC6÷14 | MPC6÷10

Submersible asynchronous electric motors

The range of 6" ÷ 14" water filled rewindable submersible motors. The high performance at the top of the market ensures high energy savings. The design, the electrical project and the Caprari International Patents are a guarantee of robustness and reliability over time.

TECHNICAL SPECIFICATIONS AND ADVANTAGES

- Rewindable water-filled
- Two different Caprari factories: Italy (MAC) and Turkey for (MPC)
- High versatility: cast iron, bronze, stainless steel, duplex and super-duplex
- Power up to 440kW
- Supply voltage: low and medium up to 3.300V
- Asynchronous three-phase - 2/4 poles
- Coupling: NEMA 6 – 8 Standard, Caprari proprietary and shaft-key
- CPLUS configuration with double insulation windings: hot water up 65°C and VSD applications
- Cable:
 - 1 flat multipolar for MPC 6-8"
 - 3 round unipolar for MAC 6 - 8-10-12-14" and MPC 10"
- SiC/SiC mechanical seal
- IP68 protection degree
- Vertical/Horizontal installation



MEDIUM VOLTAGE UP TO 3.300V

The best solution in heavy-duty, high-power applications that require high efficiency, reliability and excellent control

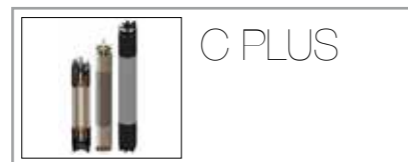

CERTIFICATIONS



MMP6÷10

Submersible permanent magnet motors

The MMP range of 6", 8" and 10" submersible permanent magnet motors is designed to achieve maximum performance and lowest costs, reducing energy consumption. This ensuring extreme reliability and improving operational continuity. MMP motors offer efficiency above 90%, ensuring immediate and measurable energy savings, lower operating costs and a faster return on investment compared to traditional motors.

TECHNICAL SPECIFICATIONS AND ADVANTAGES

- Permanent magnet construction: efficiency >90%
- Rewindable water-filled
- Motor diameters: 6-8-10"
- Coupling: NEMA 6 – 8 Standard
- Powers available: 5,5÷340HP / 4÷250kW
- Frequency/rotation speed/supply voltage:
 - 100Hz – 3000rpm – 400V±10%
 - 4 poles
 - SiC/SiC mechanical seal
 - IP68 protection degree
 - Vertical/Horizontal installation



Efficiency >90% **»»** Energy saving up to 20%

MMP VS MAC: WHAT IS THE ENERGY SAVING?

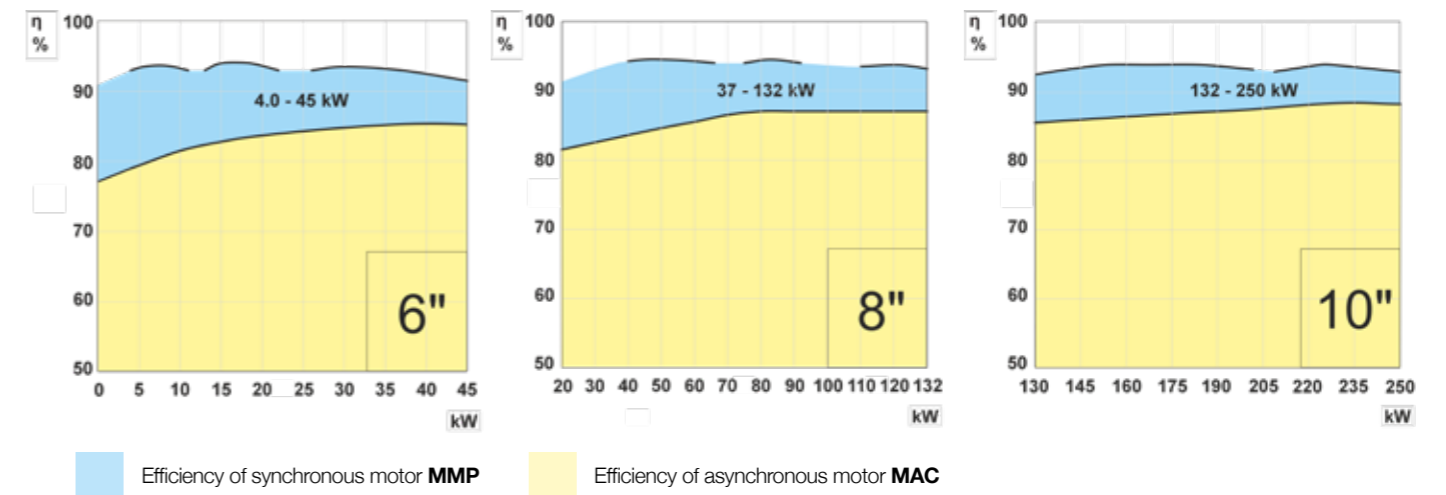

CERTIFICATIONS



MC4

4" Submersible asynchronous electric motors

The range of 4" oil filled submersible motors is perfect for coupling to 4" pumps. Ideal for small wells and irrigation.

TECHNICAL SPECIFICATIONS AND ADVANTAGES

- Oil filled construction; canned water filled version on request
- Stainless steel construction
- Asynchronous three-phase and single-phase
- Power up to 7,5kW (three-phase) and 2,2kW (single-phase)
- 2 poles
- Coupling: NEMA 4 Standard
- SiC/SiC mechanical seal
- IP68 protection degree
- Totally prefilled in the factory with dielectric/non-toxic oil approved by the Food and Drug Administration (USA).



CERTIFICATIONS



E5MX

5" Monobloc borehole pumps asynchronous electric motors

The compact stainless steel structure and the technopolymer impellers make the E5MX resistant to corrosion and sand. The integrated electric motor is protected by a double mechanical seal to guarantee durability over time. The single-phase and three-phase versions, with internal and external capacitors, ensure high flexibility of use. Ideal for water supply from wells, tanks, irrigation systems, residential, commercial and civil buildings.

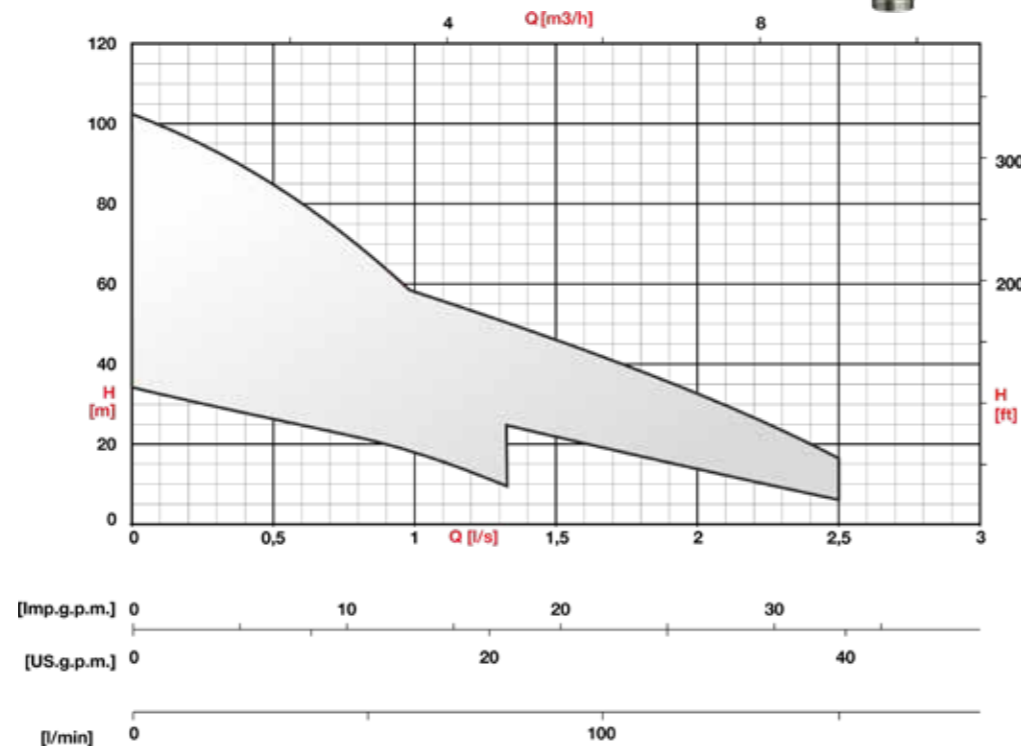

TECHNICAL SPECIFICATIONS AND ADVANTAGES

- Stainless steel construction and technopolymer impellers
- Asynchronous three-phase and single-phase
- Power up to 1,5kW
- IP68 protection degree
- Cable length: 10m
- Floating optional version

Boosters and cooling shrouds

Boosters

Borehole electric pumps in a booster configuration are an optimum solution to overcome the critical issues related to engineering, environment and maintenance encountered against equivalent traditional installations when it comes to surface mounted electric pumps: maximum silence, minimum size.

The solution is compact and robust; it allows easy vertical or horizontal installation, both in new systems and directly onto existing pipes.

The engineering solutions are:

- units in parallel, controlled in cascade through pressure and/or flow rate sensors, possibly with one or more electric pumps driven by inverters;
- direct fitting on existing lines or offtake;
- direct installation in the storage tank.



INSTALLATION TYPES

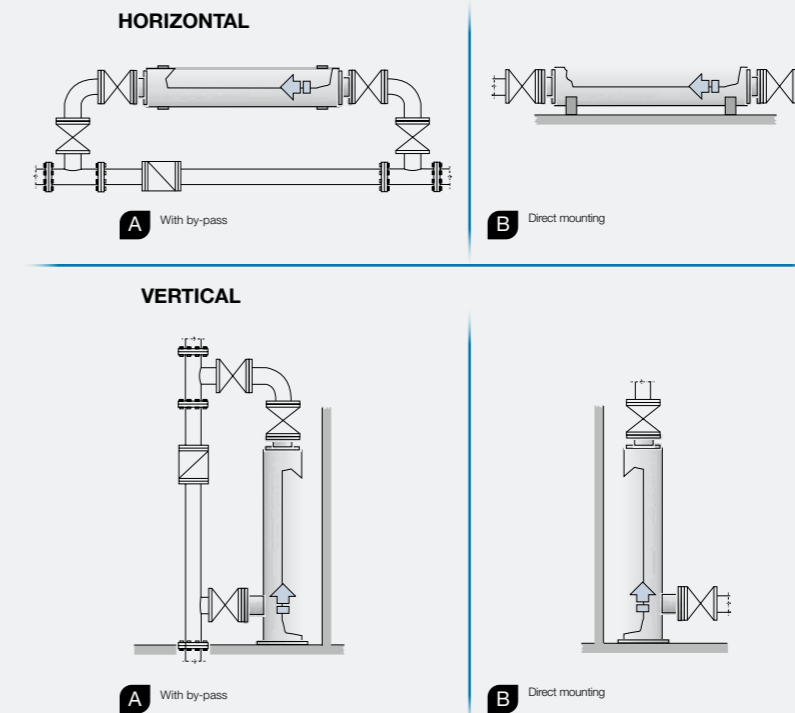

Cooling shrouds

They are the ideal solution for applications with high-temperature liquids, as they ensure optimal water speed around the motor for cooling.

Boosters and cooling shrouds are available in galvanised steel or stainless steel.

Submersible pumps and motors

P6÷P18

Vertical lineshaft pumps

The widest range of 6" ÷ 22" VTP. The extreme robust and flexible configuration consists of submersible pump, vertical lineshaft and drive unit to reach all installation depths. The IE5/IE4/IE3 efficiency of surface motors guarantees maximum energy savings. Ideal for irrigation, water supply, industry and fire-fighting systems.



TECHNICAL SPECIFICATIONS AND ADVANTAGES

EFFICIENCY

- High energy savings and low system costs
- Best hydraulic performance on the market above 80%
- IE5/IE4/IE3 efficiency class electric motors

RELIABILITY AND DURABILITY

- Robust and high quality of materials
- Advanced casting technologies
- DEFENDER: Anticorrosion device

FLEXIBILITY OF USE

- Installation depth up to 250m
- Coupling with electric motors up to 1.000kW or endothermic engines
- Installation in wells, tanks, rafts and platforms

PERFORMANCE DATA

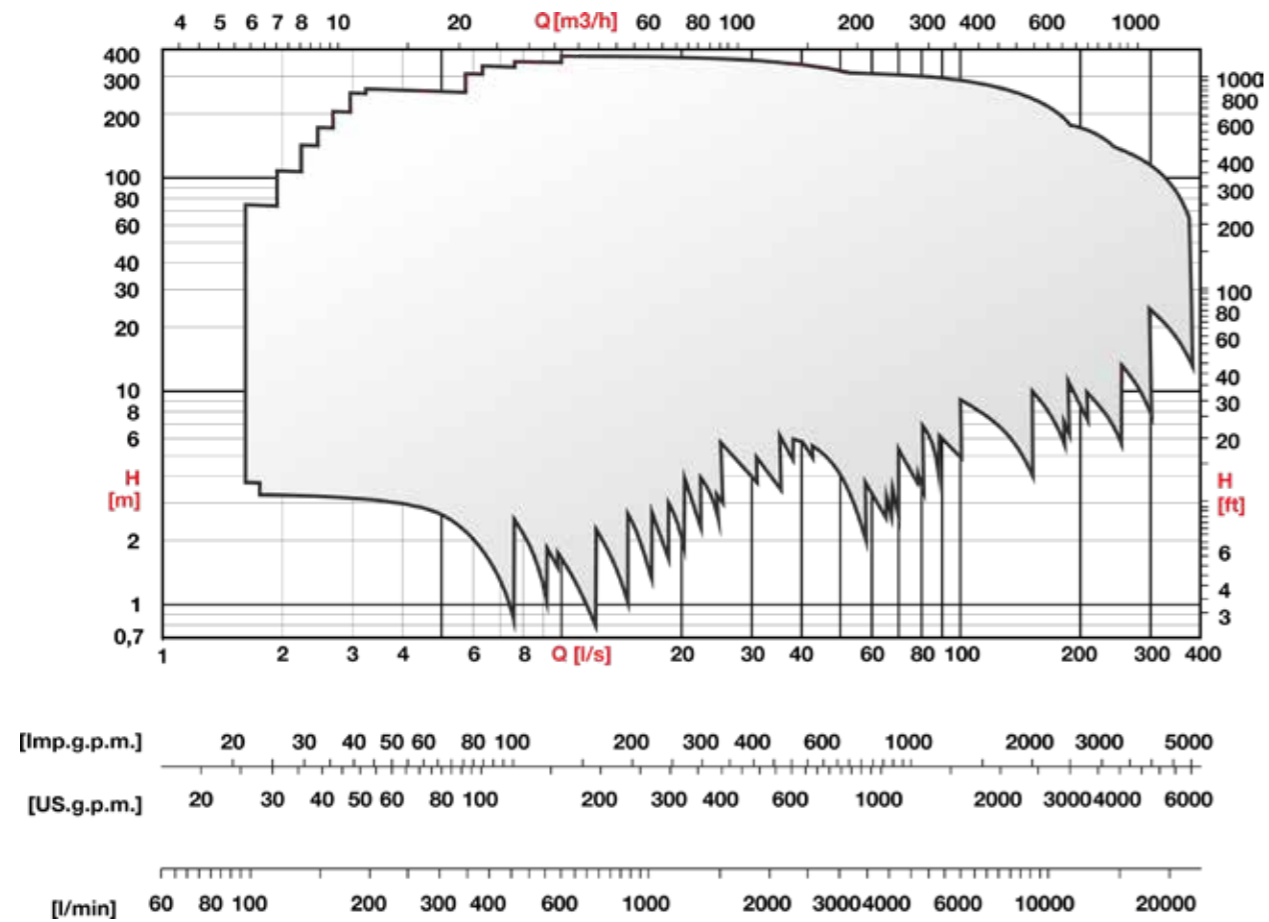

CERTIFICATIONS

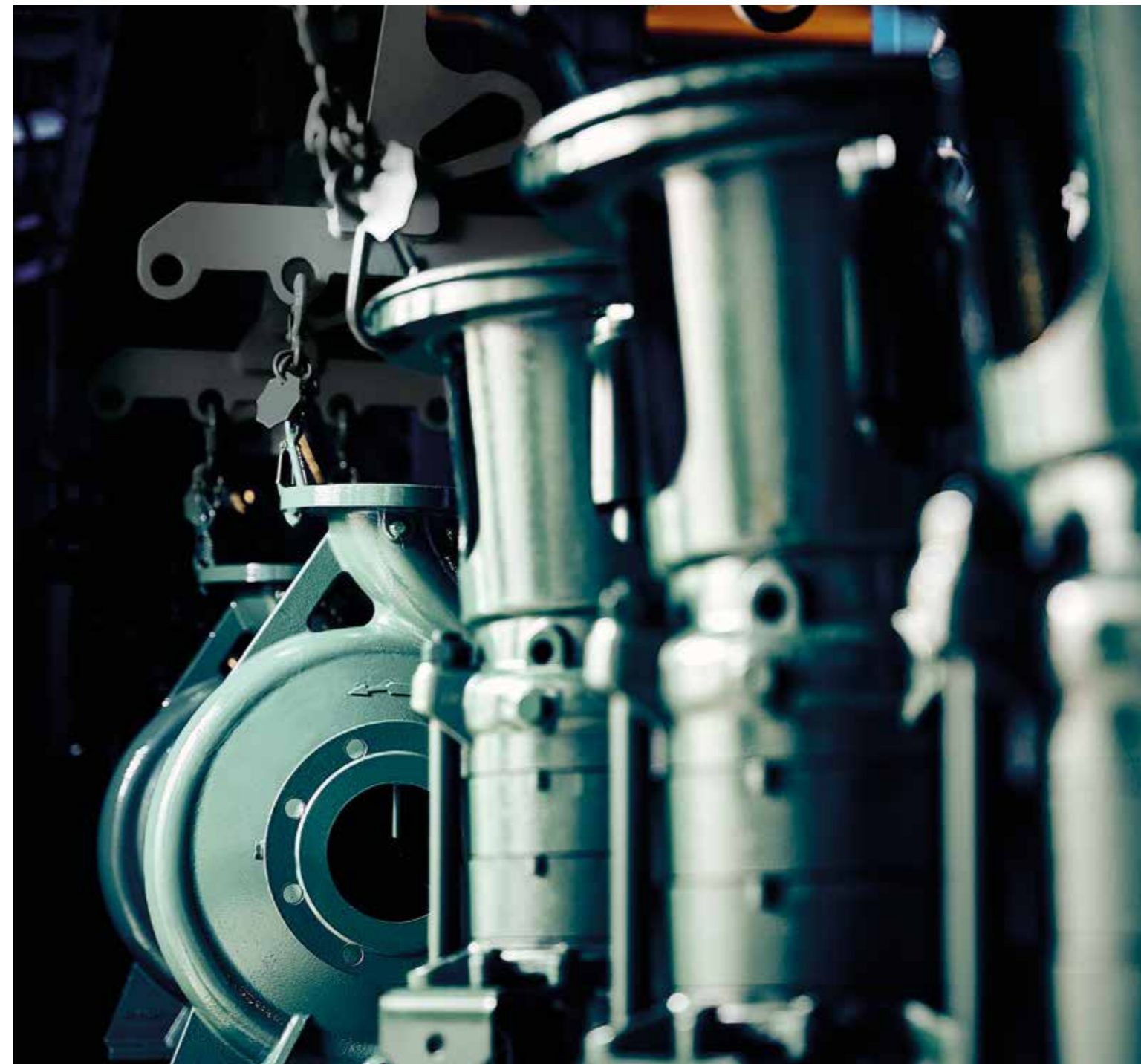

A pump for all applications: a wide range of surface pump models to meet every requirement. Coupling with IE5-IE4-IE3 efficiency class electric motors and diesel engines, many metallurgies and configurations available to ensure efficiency and durability over time. Ideal for irrigation, waterworks, industry, infrastructure, snowmaking, firefighting and desalination plants.

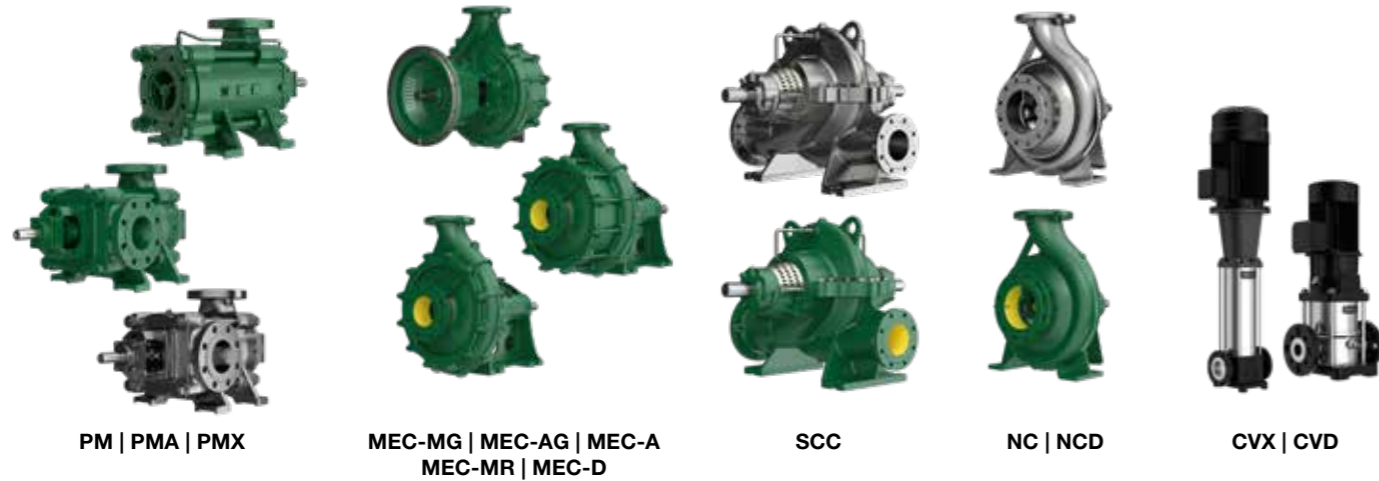

PM | PMA | PMX

MEC-MG | MEC-AG | MEC-A
MEC-MR | MEC-D

SCC

NC | NCD

CVX | CVD

One solution for all application

MATERIALS

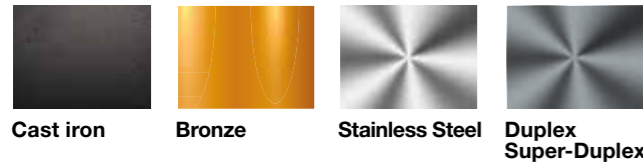

Cast iron Bronze Stainless Steel Duplex Super-Duplex

Certifications



PERFORMANCE DATA

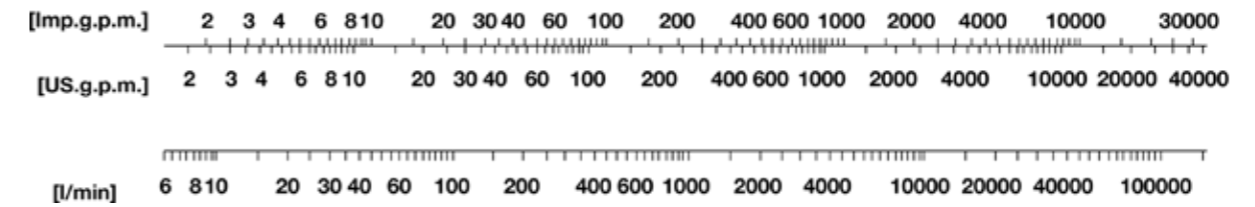
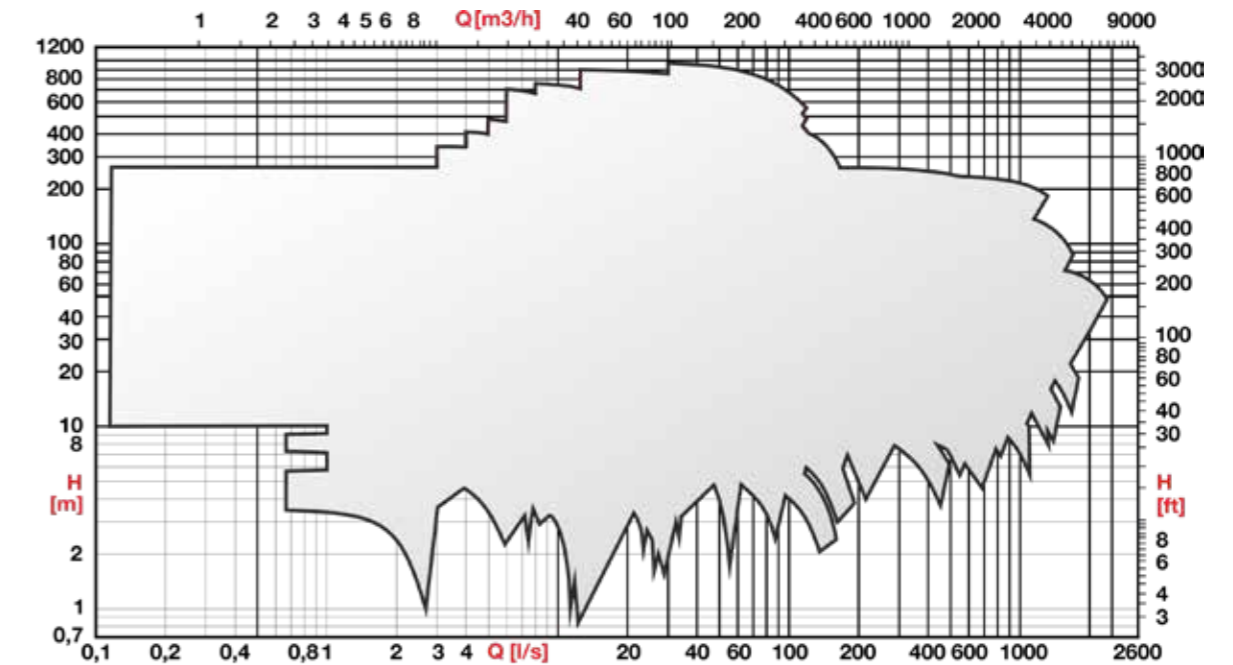

Series	MEC-AG MEC-MG BHG	MEC-D BHD
Pump DN	65 ÷ 250	40 ÷ 200
Max. power [kW]	140	132
Max. flow rate [l/s]	290	140
Max. head [m]	185	170

Series	NC NCD	CVX CVD
DN pompa	32 ÷ 250	25 ÷ 150
Max. power [kW]	50 Hz: 355 60 Hz: 355	75
Max. flow rate [l/s]	50 Hz: 450 60 Hz: 420	50
Max. head [m]	50 Hz: 160 60 Hz: 160	315 250

	SCC	PM PMA PMX	MEC-A	MEC-MR	NMC	HMU	BHR	HV	MD
	65 ÷ 700	50 ÷ 150	40 ÷ 125	65 ÷ 125	32 ÷ 150	40 ÷ 50	200 ÷ 250	18 ÷ 80	40 ÷ 100
	3000	700	132	132	90	55	37	90	18.5
	3000	700	90	132	90	55	37	90	18.5
	2500	160	130	100	180	26	280	50	60
	2500	140	130	100	180	26	280	50	60
	270	1000	140	210	95	280	25	250	85
	270	1000	90	185	95	280	25	250	85

PM | PMA | PMX

High pressure horizontal multistage pumps

Ideal for high pressure (up to 100 bar) in industrial applications, water supply, snowmaking, irrigation, reverse osmosis and desalination plants.



TECHNICAL SPECIFICATIONS AND ADVANTAGES

- High customization: axial/radial suction port, PT100 thermal probes, different metallurgies, packing gland/mechanical seal, double shaft version, high temperature application
- Coupling with surface motor with power up to 1.000kW, 2/4/6 poles in IE5/IE4/IE3 efficiency class

PRESSURE UP TO 100 BAR

- Impellers with axial thrust compensation system
- High thicknesses of the casting components

HIGH ENERGY SAVING

- High-efficiency hydraulics >80%
- Performance guaranteed over time: replaceable wear rings

REDUCED INSTALLATION COSTS

- Simple installation: suction casing radial/axial to the pipeline
- Easy pump-motor alignment: innovative baseframes

LOW NPSH VALUES

- Reduced risk of cavitation
- Reliable operation even in overhead installations

EASY MAINTENANCE

- Reduced maintenance: grease lubricated bearing on the delivery side
- Quick replacement of the sleeve and bushing from the suction side

PERFORMANCE DATA

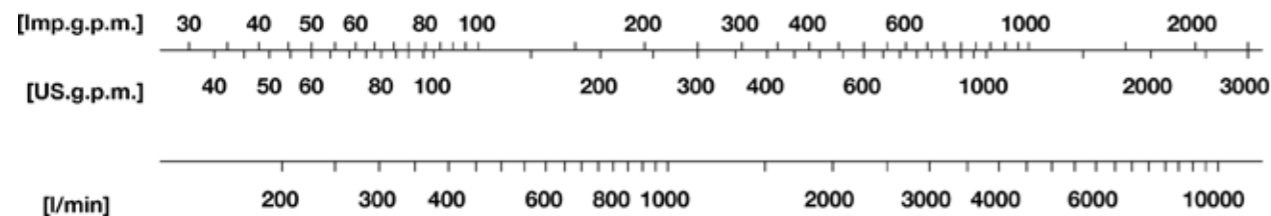
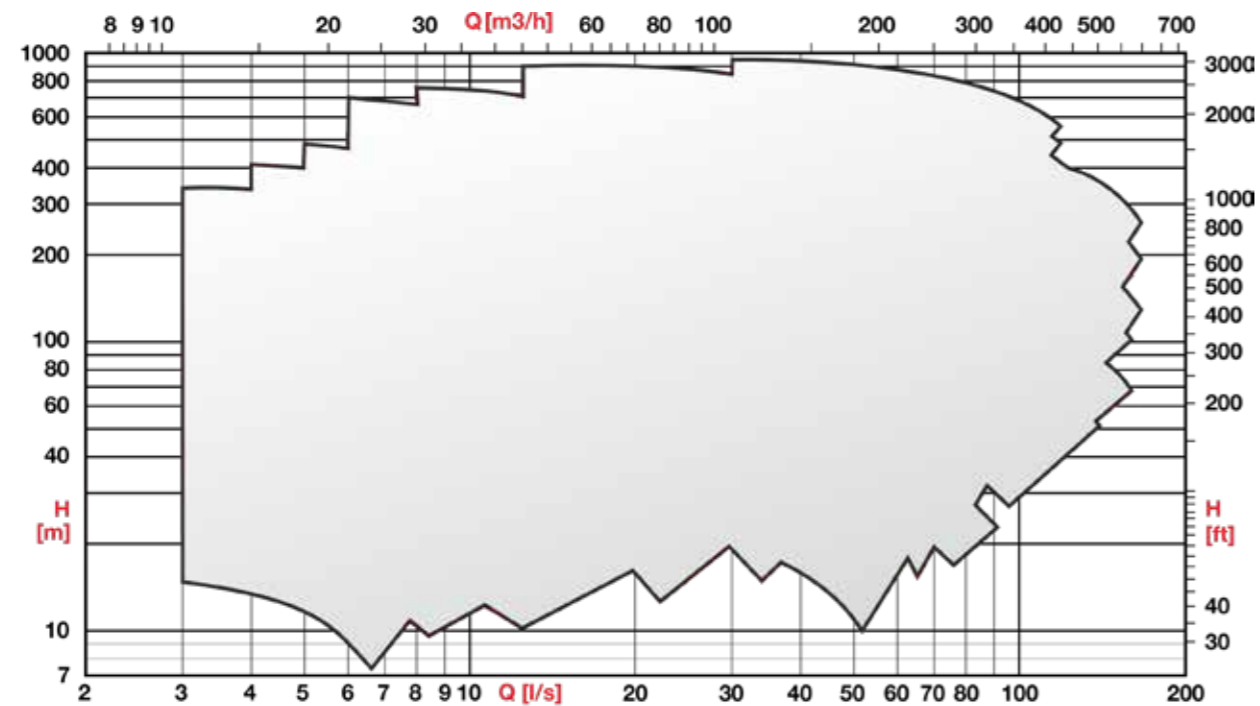

CERTIFICATIONS



MEC-MG HT | MEC-AG | BHG

SAE flanged pumps for diesel engines

Single and multi-stage centrifugal horizontal pumps designed for direct flanged coupling to diesel engines. The wide range is the ideal and complete solution for irrigation: motorpumps, hose-reels, pivot, irrigation booms drip systems and sprinkler systems.



TECHNICAL SPECIFICATIONS AND ADVANTAGES

MAXIMUM FLEXIBILITY

- SAE3 – SAE4 – SAE5 MODULAR SUPPORT
Single pump model with interchangeable connection flange
- SAE3 MONOBLOC SUPPORT
The extreme reliability of historic flanged pump
- SAE3 – SAE4 – SAE5 LIGHT VERSION
The compact version without bearing support: simple and easy to install



HEAVY DUTY APPLICATION: MEC-MG

- The ideal version for extreme applications with high vibration and stress:
 - Mechanical strength: stainless steel shaft with increased cross section
 - The best heat dissipation: oil-lubricated bearings

EASY FIT STUFFING BOX

- Easy maintenance: the stuffing box can be removed without disassembling the pump, directly on site.
- Standard on all models of the MEC-AG, MEC-MG and BHG series.
- High corrosion resistance: cataphoresis treatment of components.



PERFORMANCE DATA

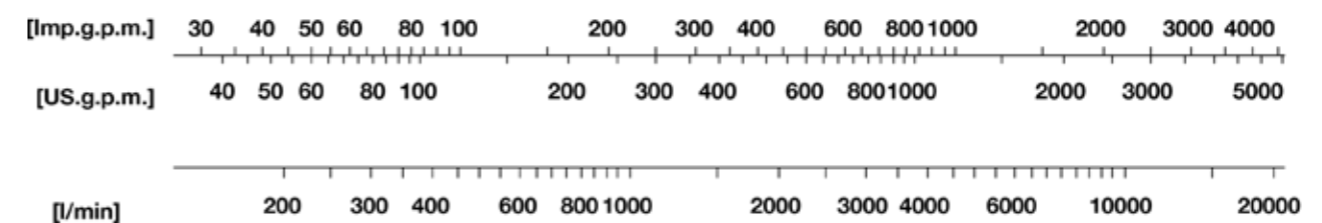
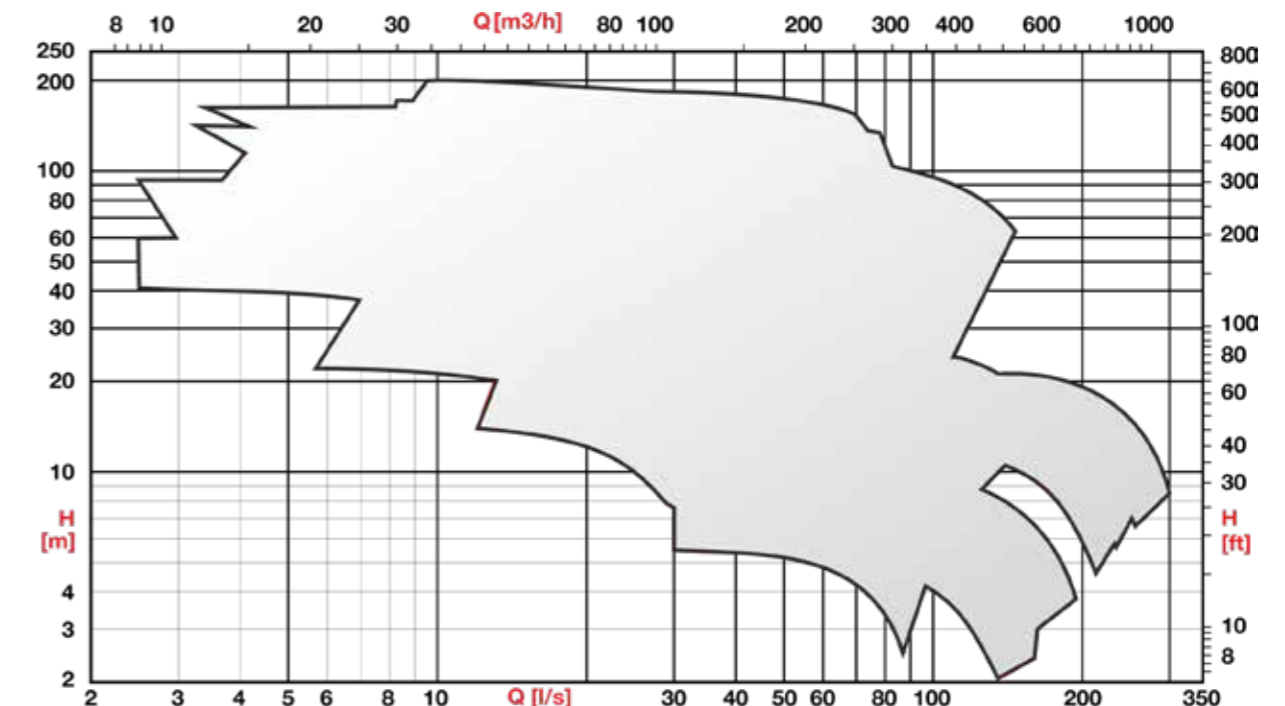

CERTIFICATIONS



SCC

Split case pumps

The robust and compact structure guarantees high performances, reduced maintenance and reliability over time. Ideal for aqueducts, civil and industrial water supply, reclamation, irrigation and industry.



TECHNICAL SPECIFICATIONS AND ADVANTAGES

WIDE RANGE

- Coupling with surface motor with power up to 3.000kW, 2/4/6/8 poles in IE5/IE4/IE3 efficiency class
- Axial/radial suction port, PT100 thermal probes, different metallurgies, packing gland/mechanical seal, double shaft version, high temperature application

MAXIMUM FLEXIBILITY

- Double shaft and horizontal/vertical installation designs
- Packing and mechanical sealing systems

ROBUSTNESS AND RELIABILITY

- Application with liquid temperature up to 140°C
- Low mechanical stress: generously sized shaft and bearings

EASY MAINTENANCE

- In-line ports: simplified installation and faster maintenance

NC | NCD

EN733 Normalized pumps

Single-stage horizontal centrifugal pumps compliant with DIN 24255/EN 733 standard and with 2009/125/EC Directive (EcoDesign-Erp). Ideal for heating and air-conditioning systems in refrigerator plants, water supply, industry, irrigation and fire-fighting units.



TECHNICAL SPECIFICATIONS AND ADVANTAGES

WIDE RANGE

- Coupling with surface motor with power up to 355kW, 2/4/6 poles in IE5/IE4/IE3 efficiency class

HIGH CUSTOMIZATION

- Different metallurgies, packing gland/mechanical seal, bronze wear ring, ANSI flanges and high temperature application up to 140°C

EASY MAINTENANCE

- The BACK PULL OUT system and connection to the motor with a flexible coupling and spacer allow quick disassembly and reassembly reducing downtime and keeping operations running smoothly.

PERFORMANCE DATA

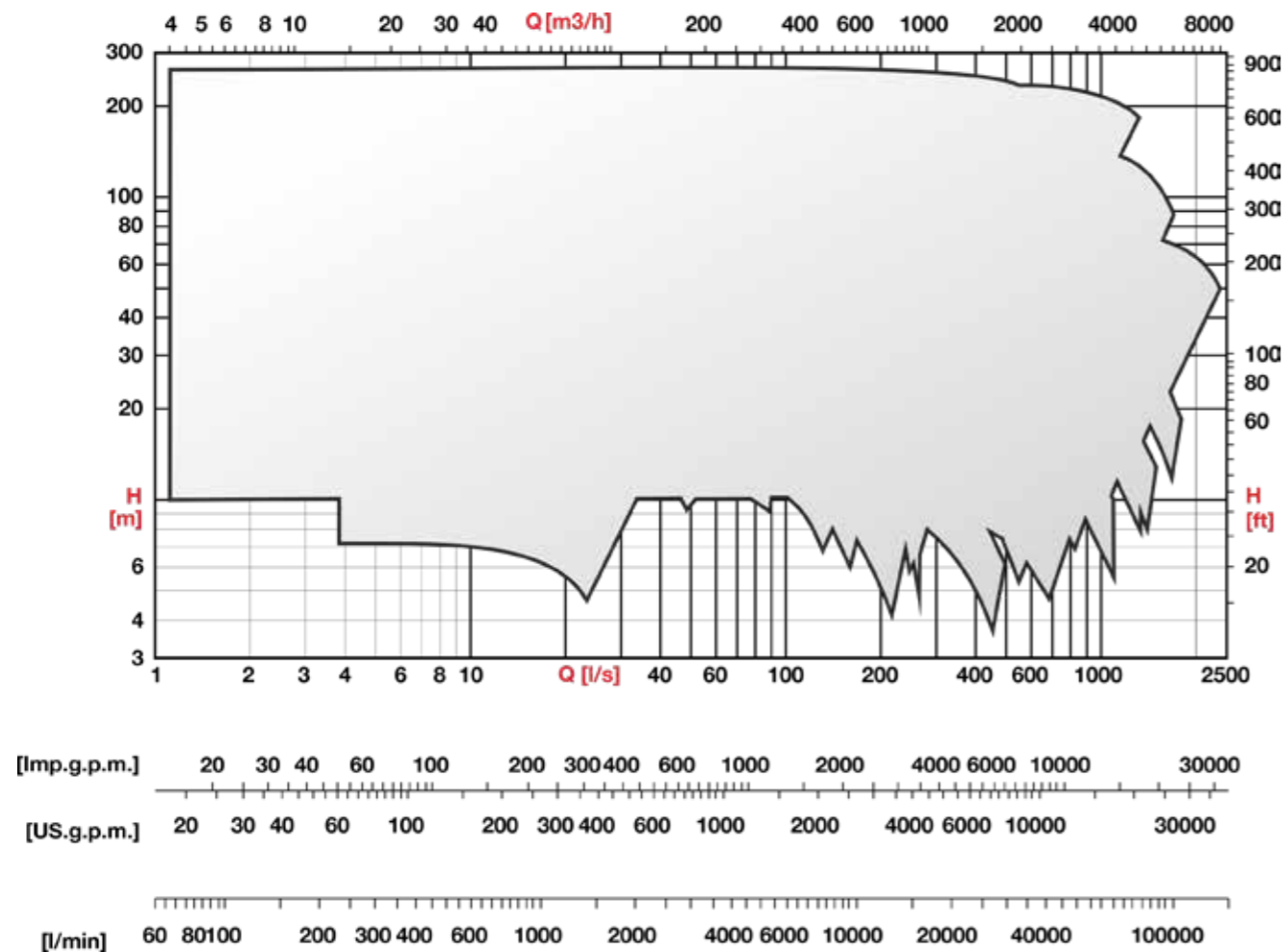

PERFORMANCE DATA

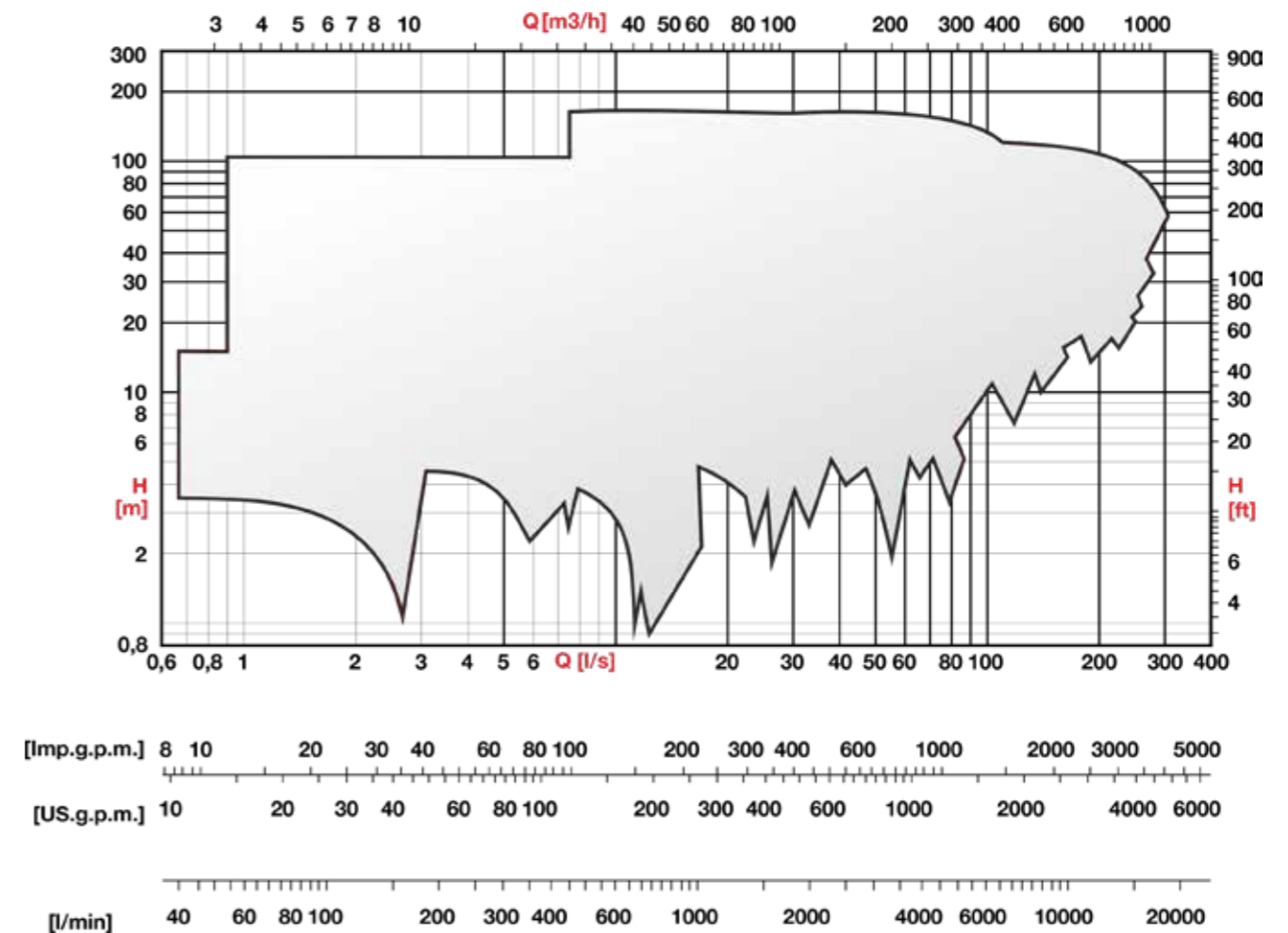

CERTIFICATIONS



MEC-A | MEC-MR

Horizontal single and multi-stage pumps



TECHNICAL SPECIFICATIONS AND ADVANTAGES

- Cast iron version with bronze impeller available
- Power up to 132kW
- Electric and endothermic coupling
- Packing gland and mechanical seals

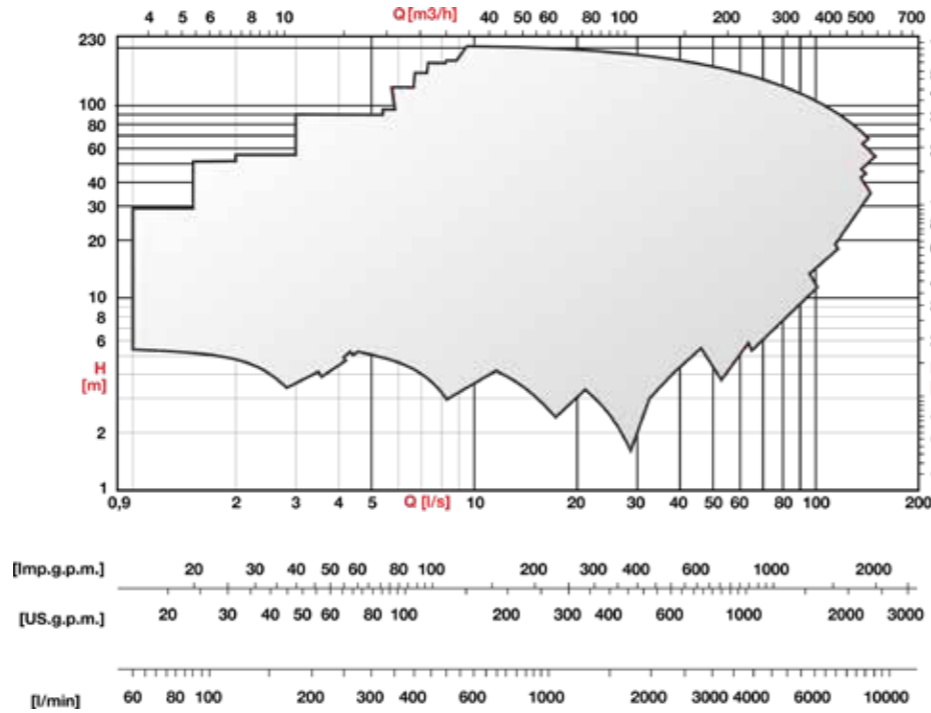

CERTIFICATIONS



NMC | NMCS | NMCF

Close-coupled centrifugal pumps with threaded/flanged ports



TECHNICAL SPECIFICATIONS AND ADVANTAGES

- Configuration: extended-shaft (NMC/NMCF monobloc) or stub-shaft (NMCS for standard motors)
- Suction and delivery port: flanged (NMC/NMCS) or threaded (NMCF)
- 2 and 4 poles IE5/IE4/IE3 electric motors
- Configuration for liquid up to 140°C
- Seal: mechanical type
- Single/three-phase versions
- Dimension according to EN733 standard
- Pumps compliance to Directive 2009/125/EC (Eco Design - ErP)

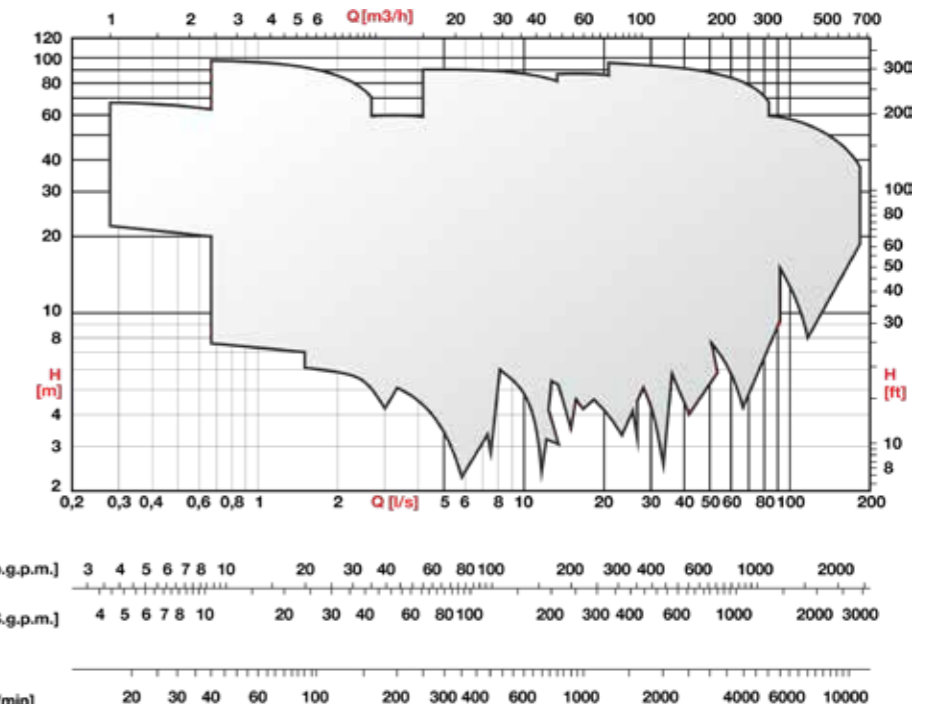

CERTIFICATIONS



MEC-D | BHD

Trailer mounted tractor pumps



TECHNICAL SPECIFICATIONS AND ADVANTAGES

- Horizontal axial centrifugal pump with one or two impellers in series
- Possibility to couple with a wheel mounted pump outfit, a semi-mobile irrigator or the hydraulic lift of a tractor
- Ideal for mobile or semi-fixed irrigation systems

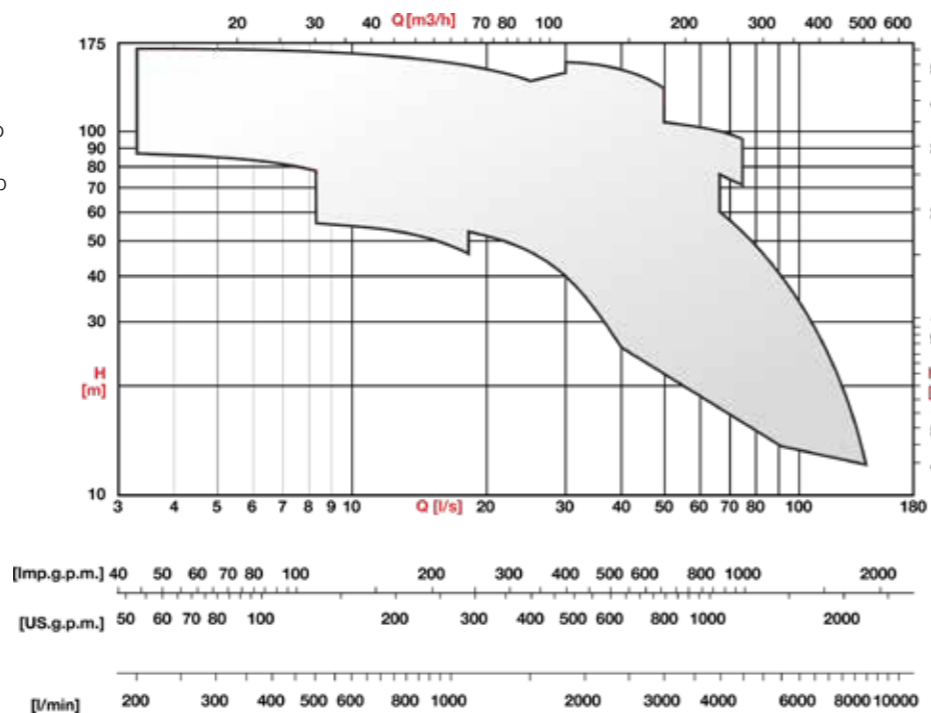

CERTIFICATIONS



MD

Horizontal monobloc electric pumps



TECHNICAL SPECIFICATIONS AND ADVANTAGES

- Single stage
- Packing gland or mechanical seal
- 2 poles three-phase electric motors

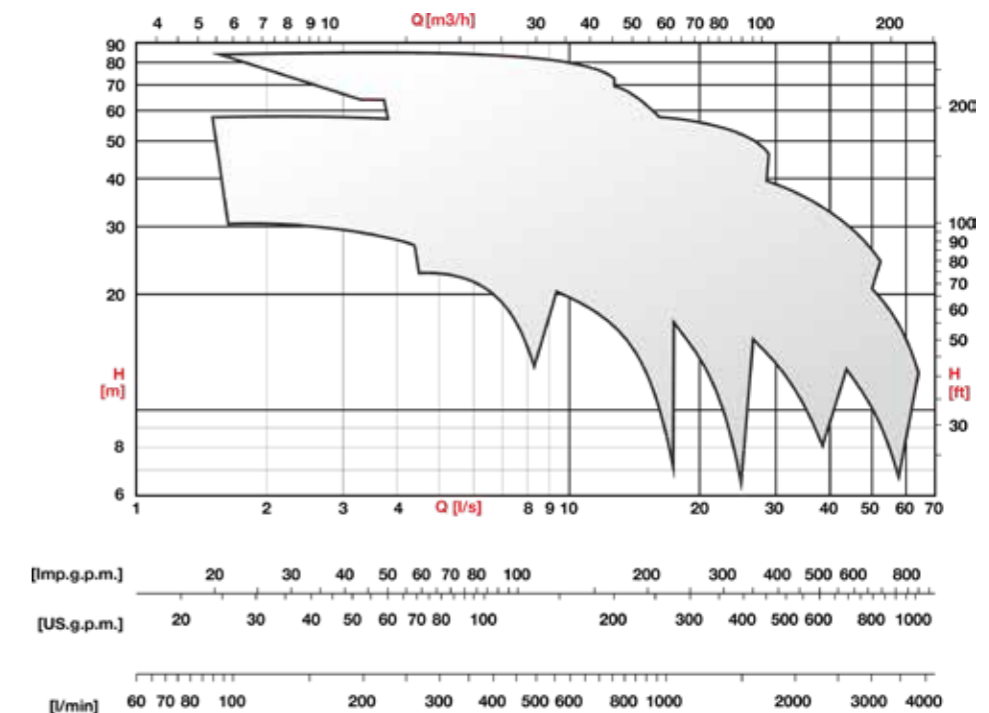

CERTIFICATIONS



CVX | CVD

Vertical inline multistage electric pumps

TECHNICAL SPECIFICATIONS AND ADVANTAGES

- Stainless steel AISI 304/316/904L and cast iron
- Power up to 75kW
- 2 poles IE5/IE4/IE3 electric motors
- Inverter onboard available
- Single/three-phase versions
- Cartridge mechanical seal easily replaceable
- Configuration for liquid up to 120°C
- Pumps compliance to Directive 2009/125/EC (Eco Design - ErP)

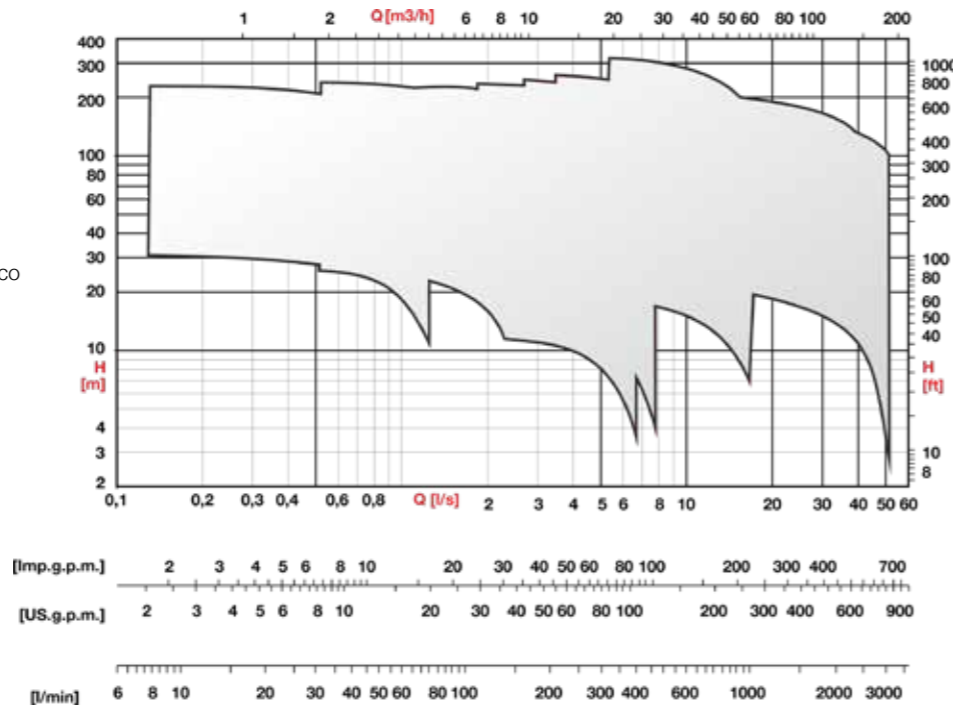

CERTIFICATIONS



HMU

Horizontal multistage pumps

TECHNICAL SPECIFICATIONS AND ADVANTAGES

- Cast iron version and bronze/stainless steel impeller available
- Power up to 90kW
- 2/4 poles IE5/IE4/IE3 electric motors
- Packing gland or mechanical seal

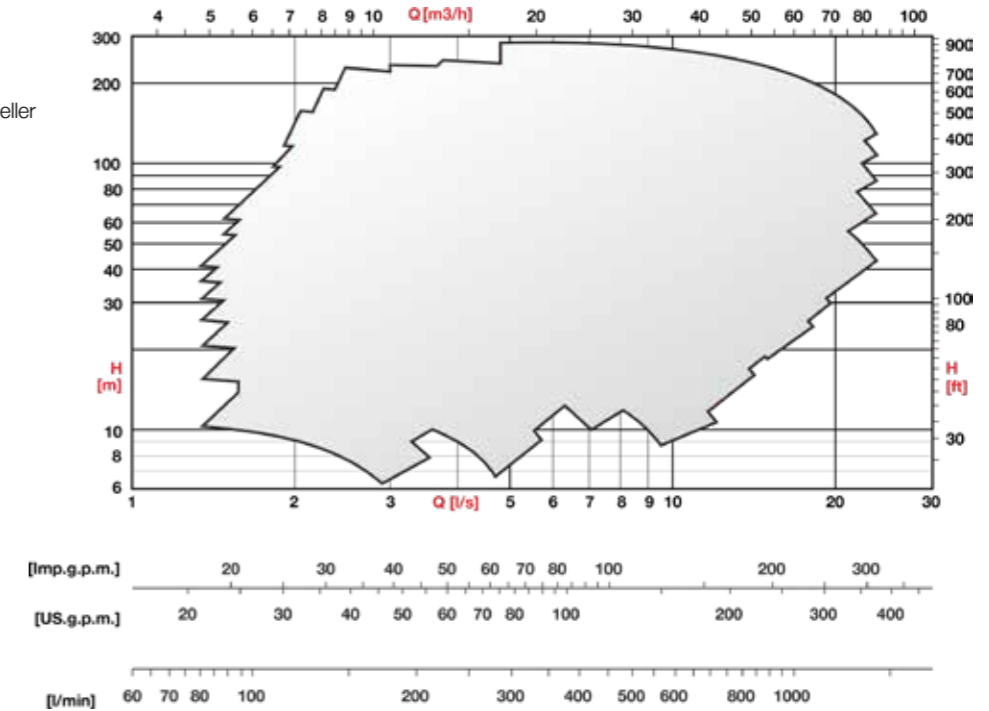

CERTIFICATIONS



HV | HMU

Vertical multistage electric pumps

TECHNICAL SPECIFICATIONS AND ADVANTAGES

- Cast iron version and bronze/stainless steel impeller available
- Power up to 90kW
- 2 poles IE5/IE4/IE3 electric motors
- Pumps compliance to Directive 2009/125/EC (Eco Design - ErP)

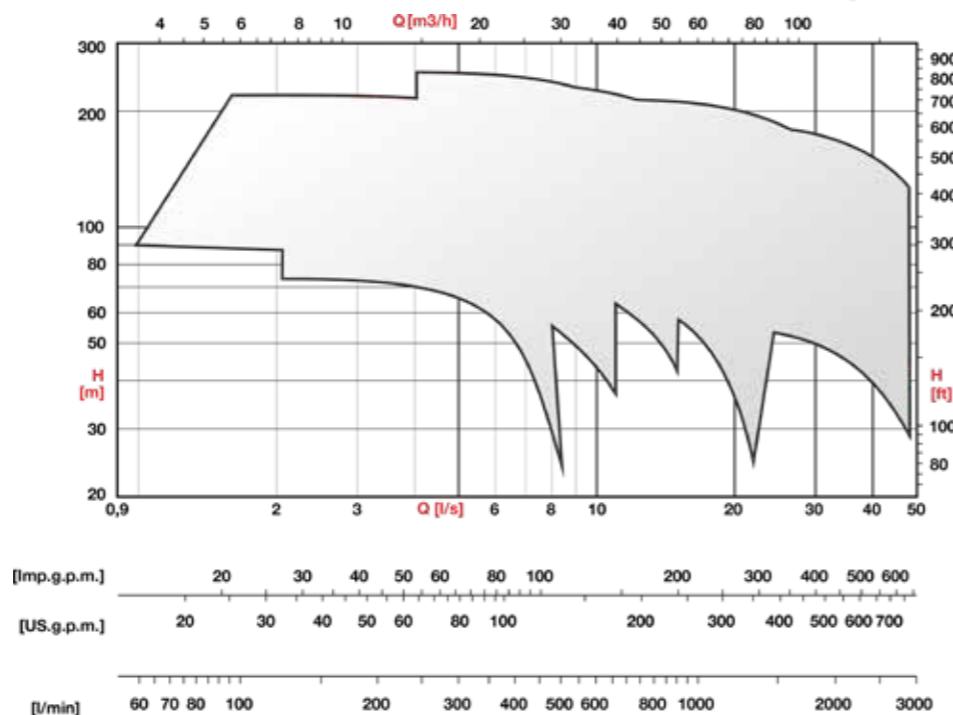

CERTIFICATIONS



BHR

Horizontal single stage pumps

TECHNICAL SPECIFICATIONS AND ADVANTAGES

- Cast iron version and bronze impeller available
- Power up to 90kW
- 4/6 poles IE5/IE4/IE3 electric motors
- Packing gland or mechanical seal

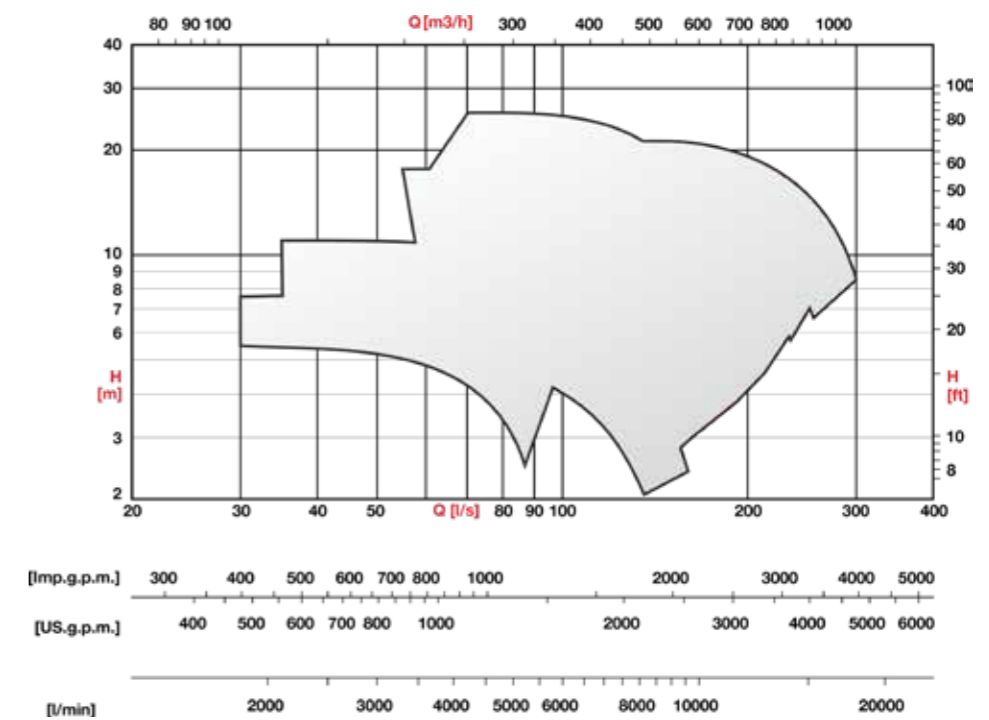

CERTIFICATIONS



Electric motors

Reliability and high performance: Caprari surface electric motors are designed for those seeking ready to use solutions without compromising on quality. A complete and integrated offer: vertical lineshaft and pump on baseframe units are completely made by Caprari.

A single and comprehensive solution for a top-performing product, built on our expertise to ensure maximum application flexibility and to reduce energy consumption throughout the entire system lifecycle.

The Caprari range of surface motors is designed to ensure high performance, energy efficiency and reliability in the most demanding applications.

TECHNICAL SPECIFICATIONS AND ADVANTAGES

- Power from 0,37 to 3.000kW
- 2/4/6/8 poles
- Single/three-phase
- Low and medium supply voltage
- IE5 / IE4 / IE3 efficiency class
- Horizontal and vertical configuration
- Accessories and variants:
 - Dedicated supply voltage
 - Insulated bearing for VSD application
 - Class H windings (H)
 - Tropicalisation
 - PTC/PT100 thermal probes



NC.E | P.E | P.A

Horizontal and vertical lineshaft pumps for firefighting systems

Series developed to meet the real needs of those who work daily with firefighting installations: reliability and easy maintenance. Coupling with electric motors or diesel engines ensures maximum flexibility.

Caprari's wide range of firefighting pumps includes:

- NC.E: normalized pumps compliant with UNI EN 12845 and UNI EN 12259-12 Standards
- P.E: vertical lineshaft pumps compliant with UNI EN 12845 and UNI EN 12259-12 Standards
- P.A: vertical lineshaft pumps UL448 certified

UNI EN 12845 and UNI EN 12259-12 STANDARDS

UNI EN 12845 and UNI EN 12259-12 are European Standards specify parameters and requirements for pumps used in firefighting systems.

NC.E and P.E have been developed to ensure high performance and maximum reliability, responding to all requirements introduced by the Standards, including component materials (impeller and wear ring in stainless steel/bronze), performance Q/H/NPSH, EN ISO 9906 Grade 2B performance tolerances and indication of the nominal flow rate Q_r on the nameplate.

UL448 CERTIFICATION

Caprari invests in the most rigorous international certifications: a strategic choice for those who want a system that not only works but also guarantees continuity and protection over time.

UL448 certification is one of the world's most recognised standards in the firefighting sector. It is a guarantee that every pump meets the highest standards of safety, reliability and performance, even in the most extreme conditions. Requirements include strictly construction control and manufacturing tolerances.

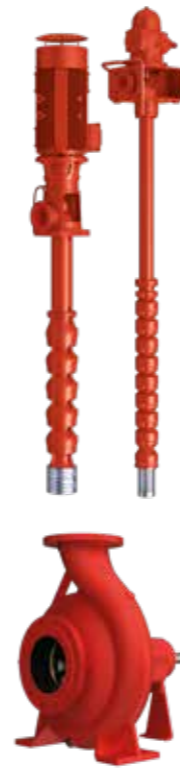

PERFORMANCE DATA | P.E - EN 12259-12

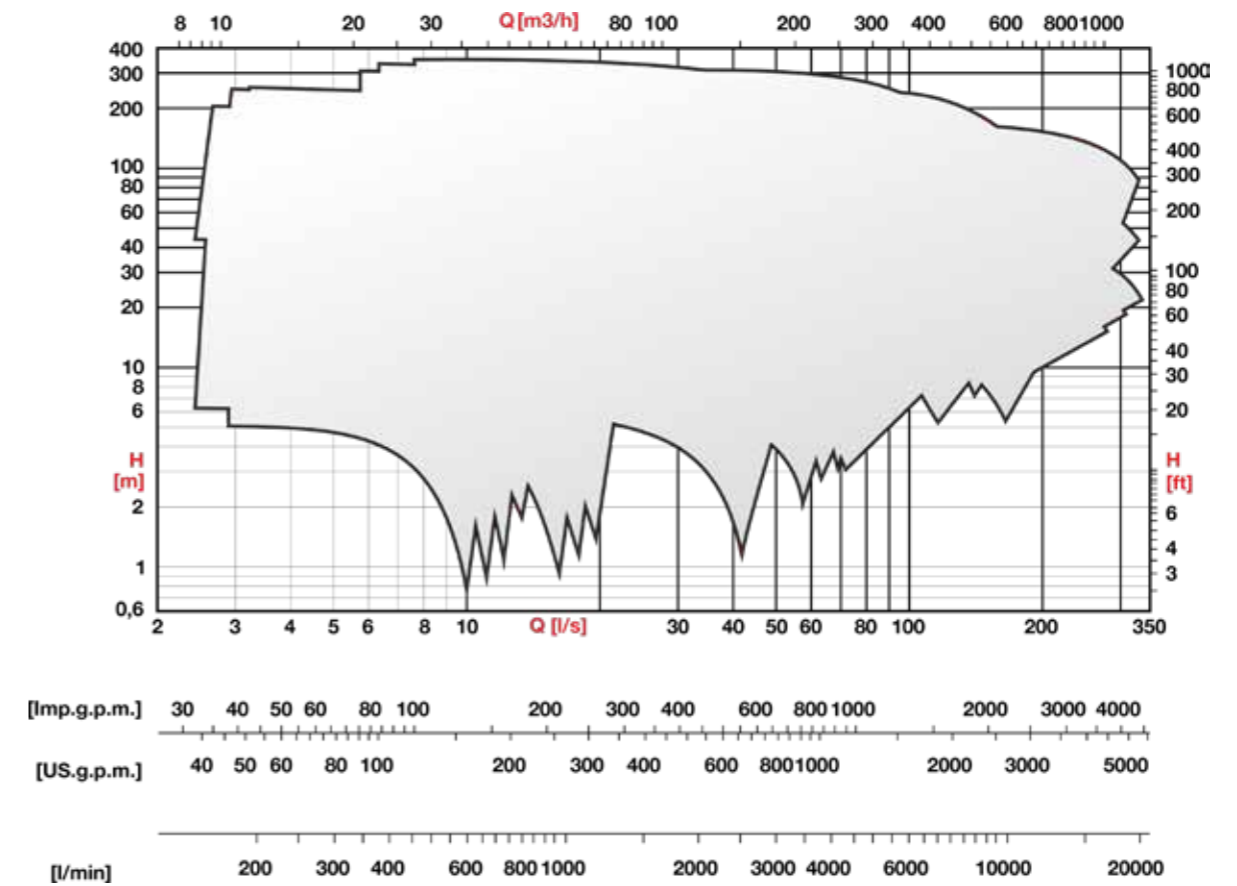

PERFORMANCE DATA | NC.E - EN 12259-12

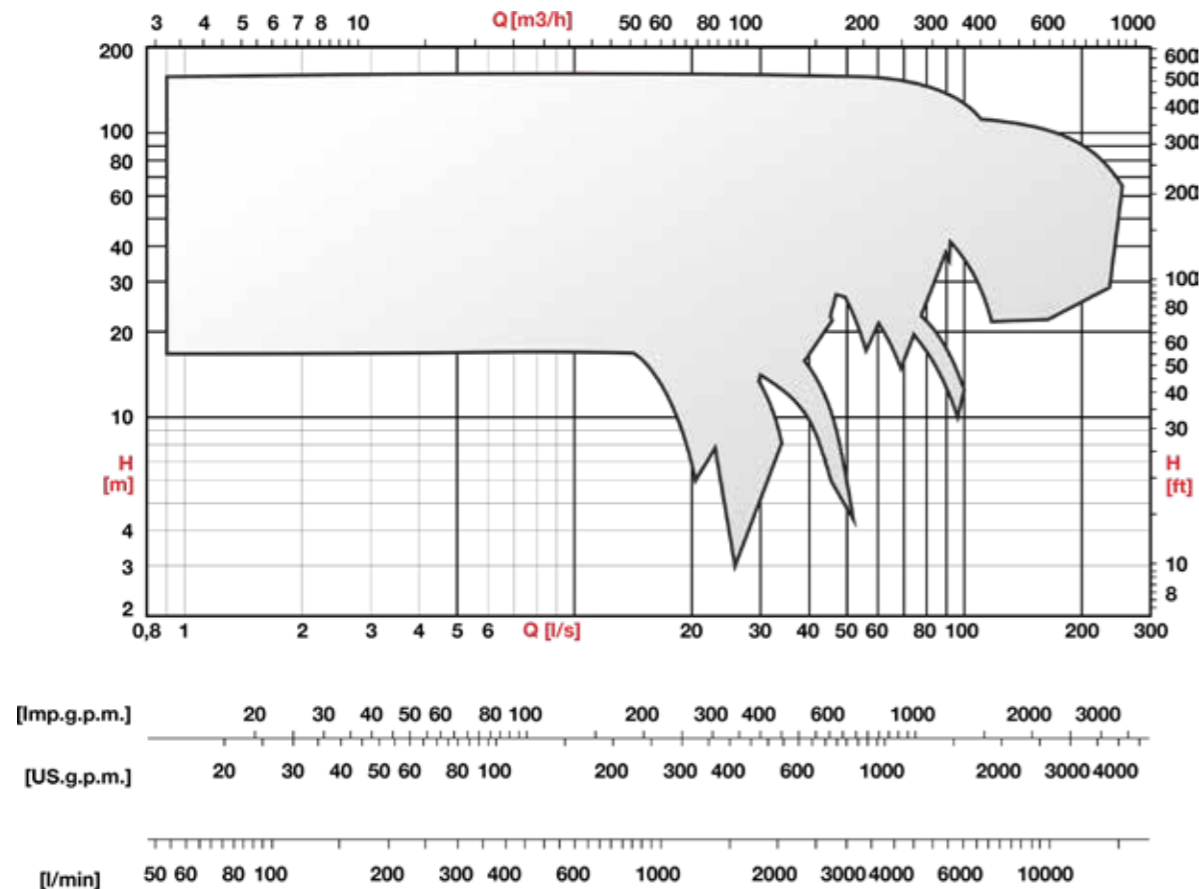

PERFORMANCE DATA | P.A - UL448

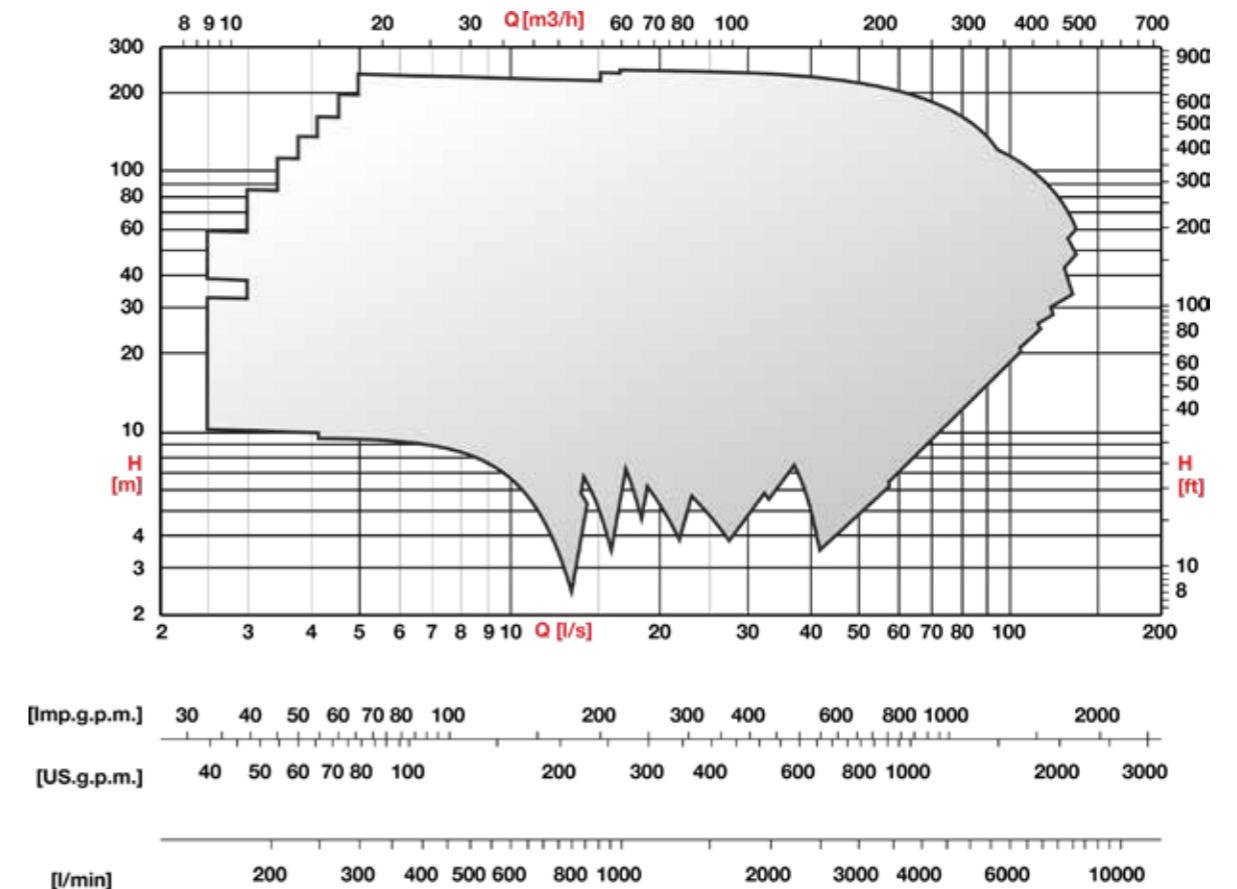

K+: the next generation of wastewater pumps

The wide range of the K+ series is designed for wastewater containing solids and gases. The excellent quality of the hydraulic profiles ensures maximum efficiency. The pump's exceptional compactness ensures maximum reliability and easy installation.



PERFORMANCE DATA

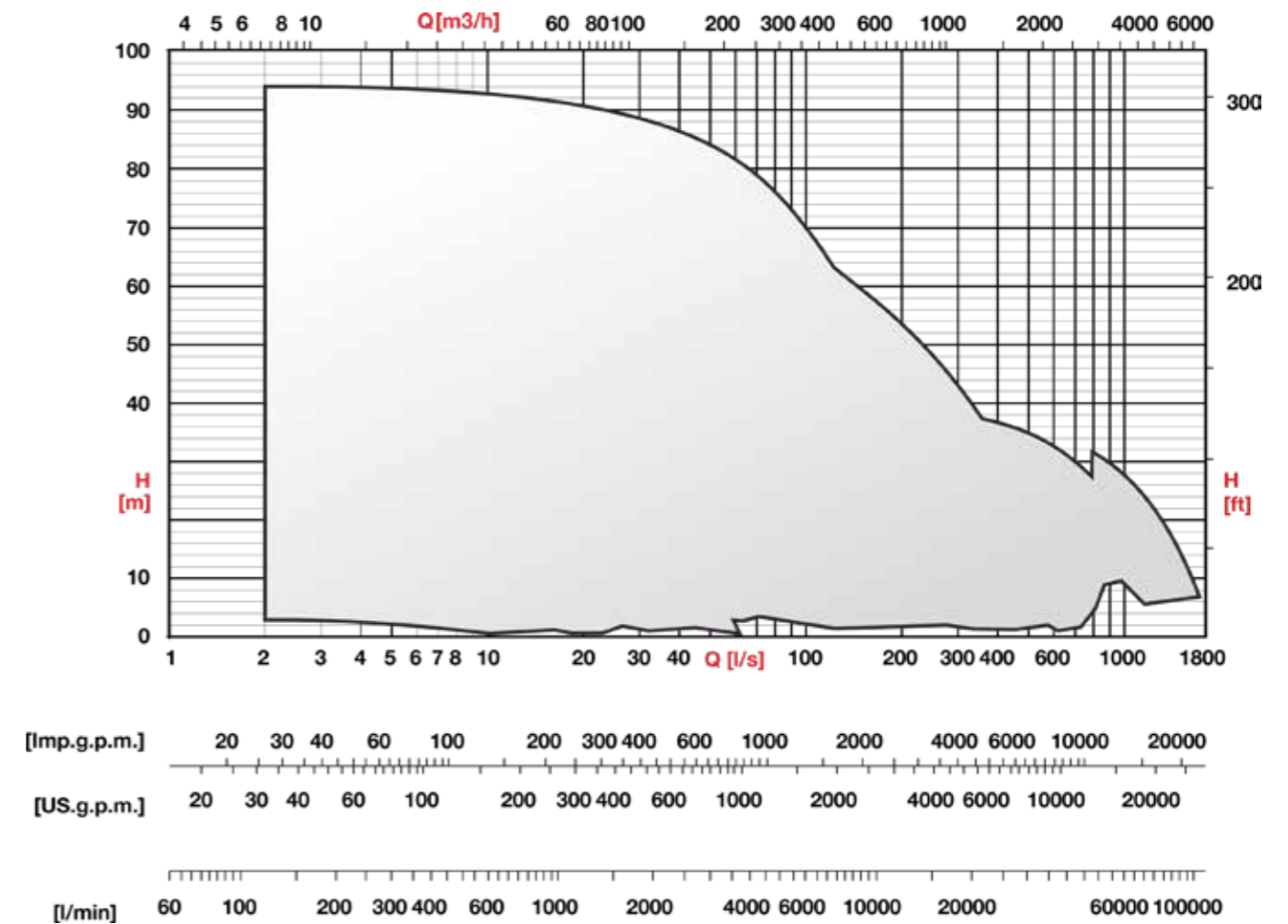

Series		K+ ENERGY	K+ HIGH FLOW	KCA HIGH EFFICIENCY
Pump DN		40 ÷ 350	400 ÷ 500	65 ÷ 350
Max. power [kW]	50 Hz	180	345	180
	60 Hz	100	250	100
Max. flow rate [l/s]	50 Hz	800	1600	700
	60 Hz	700	1700	700
Max. head [m]	50 Hz	70	40	90
	60 Hz	55	40	75
ATEX version		●		●

One solution for all application



MATERIALS



PAINTING

- CERAMIC
- ANTI-ABRASION
- ANTI-EROSION

K+ Energy: Innovation and Reliability

K+ NON-STOP; ANTI-CLOGGING SYSTEM

The only wastewater pump featuring 4 combined anti-clogging effects



The widest free passages on the market



Fibre cutting system in the area behind the impeller



Impeller cleanliness and bearing protection



Solid body anti-sedimentation system



IE3 EFFICIENCY CLASS MOTORS

- Premium performance
- Maximum energy saving

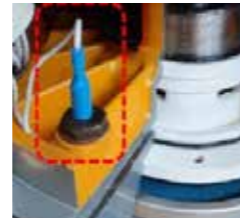

CONDUCTIVITY PROBE

Standard on all models, including the ATEX version (Caprari International Patent) Motor protection against liquid seepage



DRY WET

- Patented oil cooling system
- Simple operation

CAPRARI INTERNATIONAL PATENT

KCA series PERFORMANCE DATA

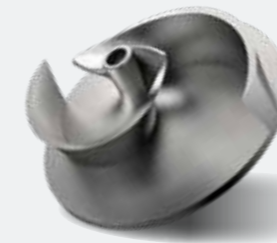

HIGH-EFFICIENCY IMPELLER

- Open double-blade construction: efficiency above 80%
- Maximum wear resistance: hardened cast iron

FIXING SYSTEM (Caprari International Patent) IMPELLER ADJUSTMENT SYSTEM

- Simple adjustment of the impeller disc via external screw
- Simplified maintenance



GREEN BOX
caprari

GREEN BOX App

- Optimises pump efficiency and reduces energy consumption
- NON-STOP anti-clogging function for pump counter-rotation in case of block

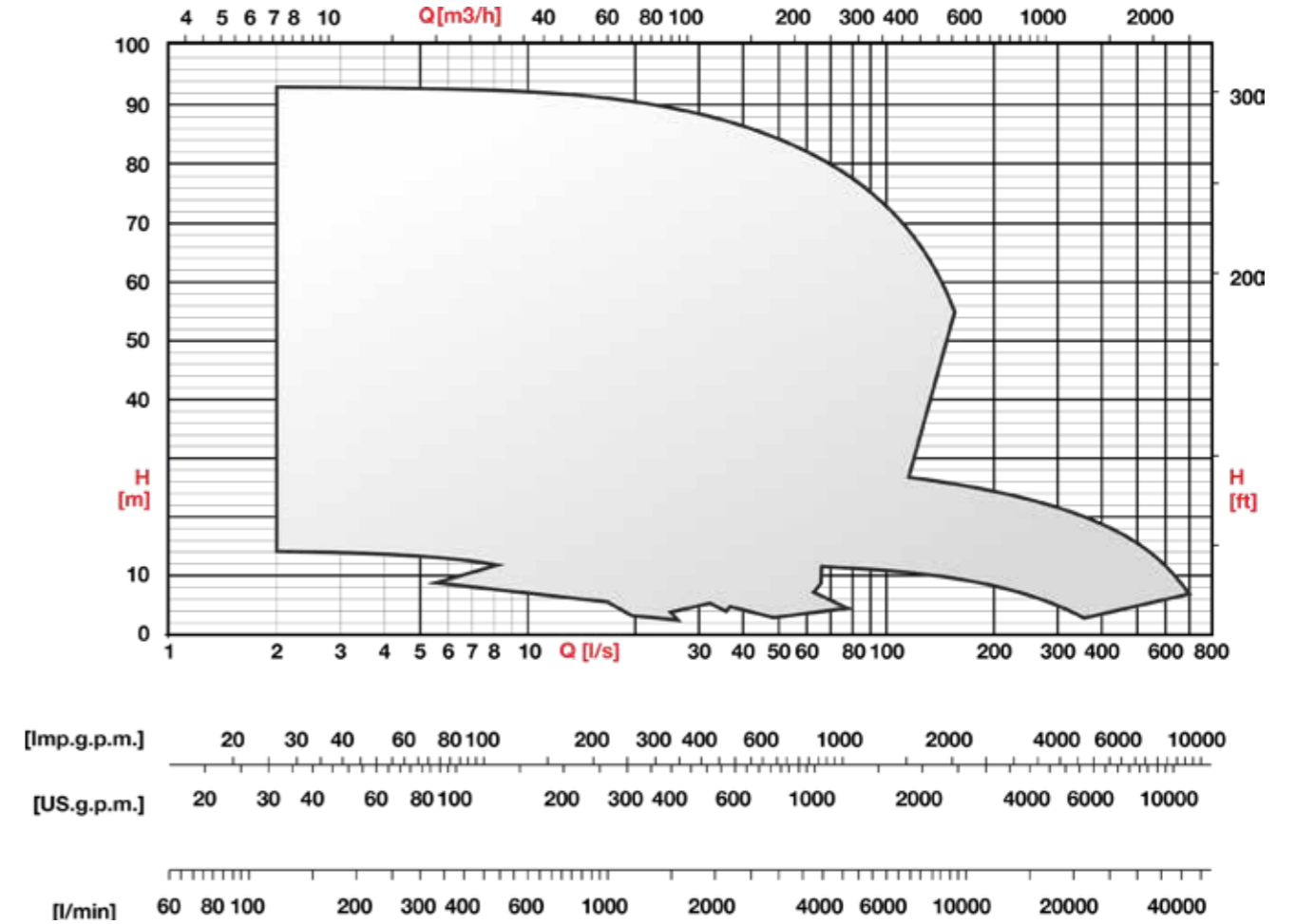

TANK



DRY CHAMBER



A SINGLE PUMP MODEL FOR MULTIPLE INSTALLATIONS

D-M

Drainage and wastewater pumps

Engineered to satisfy all the requirements for handling drainage water.

This wide range of models includes:

- lightweight electric pumps which are specially designed for domestic use and are easy to handle.
- robust pumps for building sites capable of handling even the most heavy-duty applications.

TECHNICAL SPECIFICATIONS AND ADVANTAGES

RELIABILITY AND DURABILITY

- Abrasion resistance: high-quality materials
- Double mechanical seal for protection against dry running
- Electric motor thermal protection

FLEXIBILITY OF USE

- Horizontal/vertical delivery port with threading/flanging
- Single/three-phase versions with and without float switch
- Installation with support feet or duck-foot

EASY MAINTENANCE

- Light and easy to handle
- Easily accessible electric motor
- Commercial mechanical seals easy to find



PERFORMANCE DATA

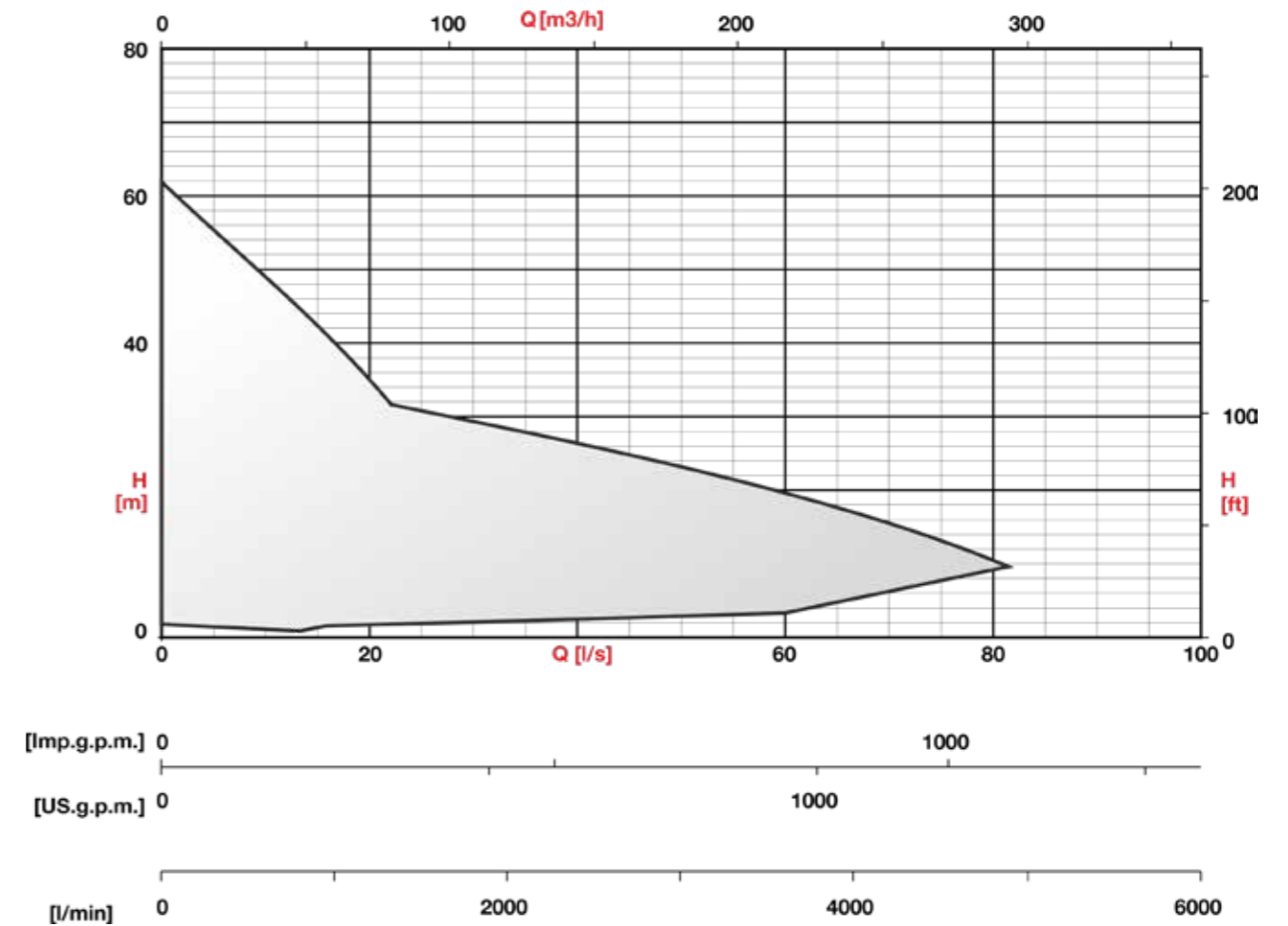

INSTALLATION TYPES

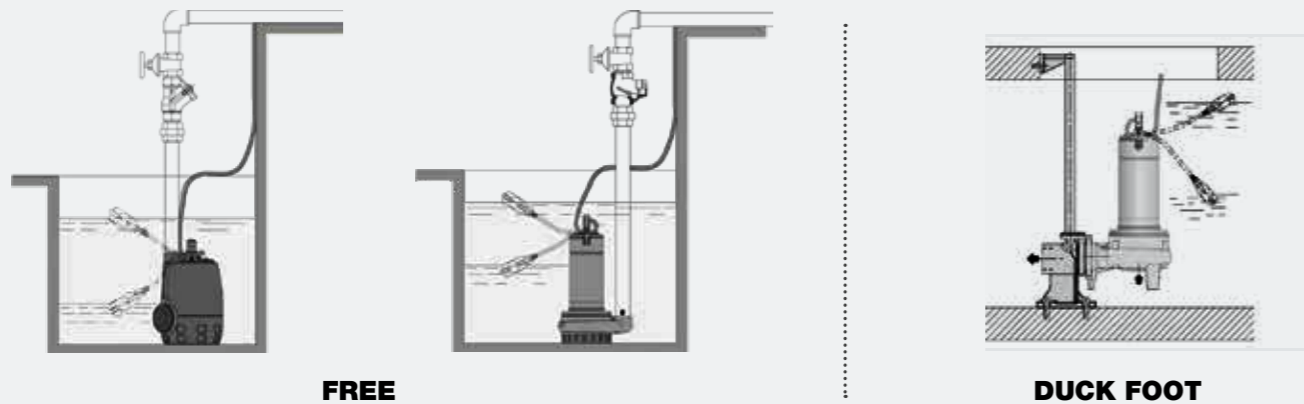

Series		D	M
Pump DN		G 1/4 ÷ DN150	G 1/2 ÷ DN65
Max. power [kW]	50 Hz	22	2,6
	60 Hz	22	2,6
Max. flow rate [l/s]	50 Hz	90	48
	60 Hz	90	48
Max. head [m]	50 Hz	65	28
	60 Hz	65	28
Impeller		Channels Vortex	Channels Vortex With shredder
Metallurgies		Cast iron Stainless steel Noryl	Cast iron Stainless steel

KK

Surface monobloc electric pumps coupled with standard electric motors

TECHNICAL SPECIFICATIONS AND ADVANTAGES

ENERGY SAVING

- Hydraulic efficiency >80%
- IE5/IE4/IE3 efficiency motors

VERSATILITY

- Horizontal/vertical version
- Single/multi-channel, vortex and high efficiency impeller

RELIABILITY AND DURABILITY

- Compact construction and high-quality materials
- Double mechanical seal for motor protection

EASY MAINTENANCE

- Easily accessible electric motor
- Commercial mechanical seals easy to find



Series	K-KOMPACT	
Pump DN		80 ÷ 350
Max. power [kW]	50 Hz	200
Max. flow rate [l/s]	50 Hz	750
Max. head [m]	50 Hz	65
Metallurgies		Cast iron Bronze Stainless steel

PERFORMANCE DATA

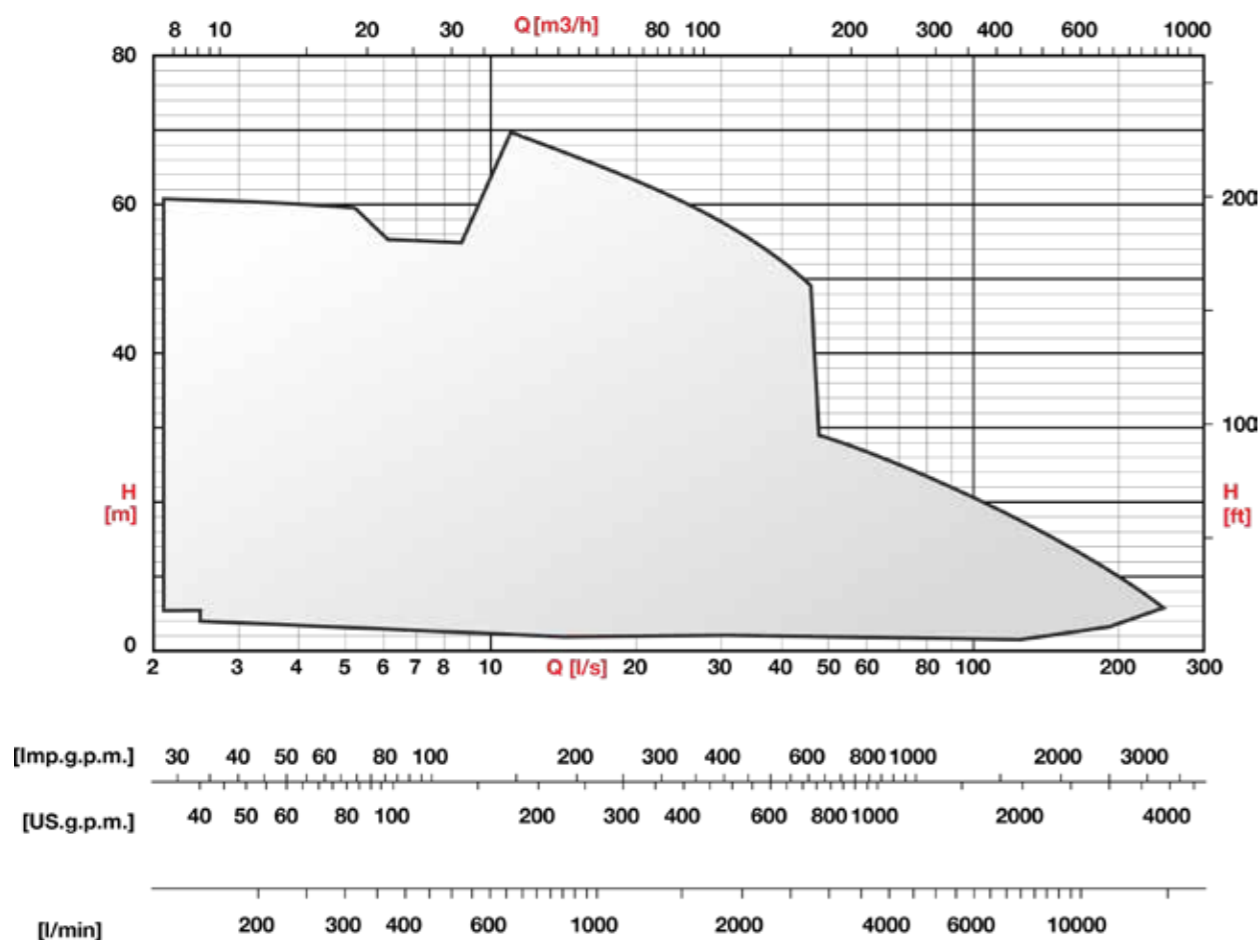

Mixer and flow accelerators

Mixing systems

Designed to meet all civil and industrial applications. The innovative design and carefully selected construction materials achieve the very best efficiency in terms of running economy and reliability.

THE RANGE

- CMD(W): horizontal submersible mixers with direct drive
- CMR: horizontal submersible mixers with planetary gear unit
- CMB: horizontal submersible flow accelerators with planetary gear unit

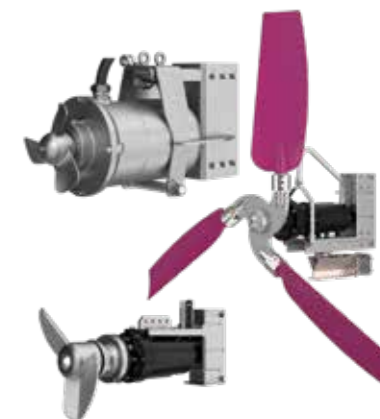

Series	CMDW	CMD	CMR	CMB
Max. power [kW]	4	4	18,5	4
N° of poles	4 - 6	4 - 6	4	4
N° of blades	3	3	2	3
Coupling motor type	direct	direct	with planetary gear unit	with planetary gear unit
Metallurgies	Stainless steel	Cast iron	Cast iron	Cast iron

MIXOFLUSH

Cleaning system

System for the automatic cleaning of the lifting stations even in critical conditions:

- prevents sedimentation at the bottom of the tank of suspended substances in the liquid
- stops the formation of foam and surface crusts, mixing oils and greases with pumped wastewater, to prevent them from building up on the surface and forming froth and crusts.



OXY-FLOW

Aeration system

Ideal for oxygenation and homogenisation processes in wastewater treatment plants:

- Compact and easy to install
- Ideal for rainwater collection tanks
- Installation in tanks of any shape and size



GREEN BOX

Exclusive system, unique on the market

Caprari's patented software, enables remote control of electric pumps, optimizing the duty point via smartphone, tablet or PC:

- Real-time monitoring of pump system performance
- Consumption reduction and fault prevention
- Active function: remote control and shutdown of the pump with a click

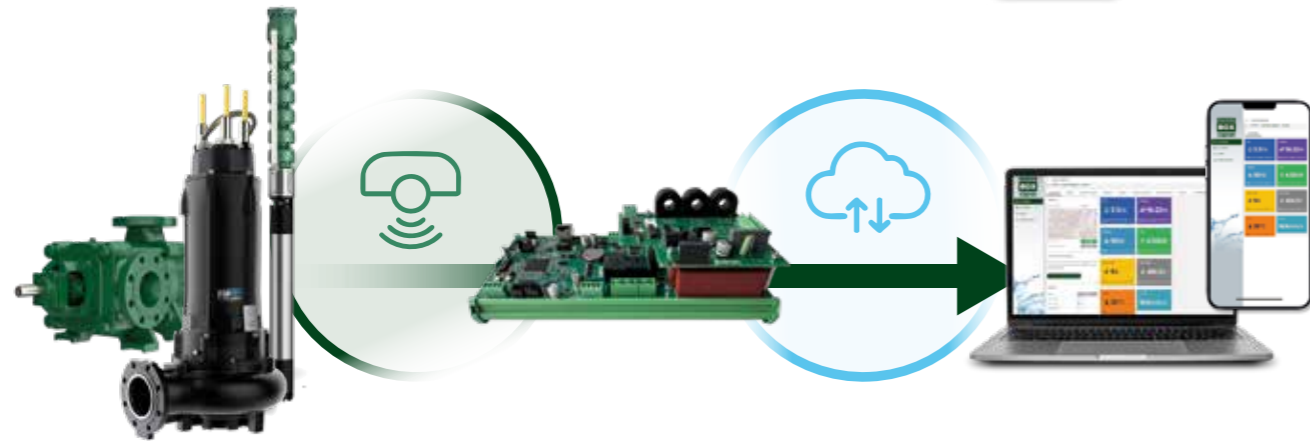

OPTIONAL	LTE CONNECTION		STAND-ALONE TOUCHSCREEN DISPLAY	
-----------------	-----------------------	--	--	--

MANAGED PARAMETERS

Pressure | Flow rate | Vibration | Temperature

Connections

Ethernet | Wi-Fi | LTE

EASY INSTALLATION

GREEN BOX can be easily installed in existing panels or new systems.

Caprari can supply the complete solution, with factory pre-assembled devices and installation assistance.

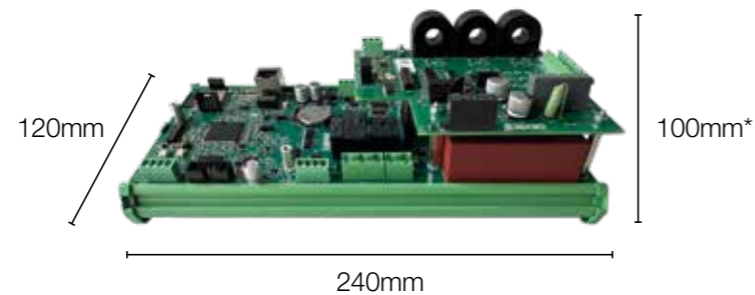

Device height: 100 mm with Energy Meter, 64 mm GREEN BOX only

Extra features for total protection

Modular structure allows upgrade to **GREEN BOX PRO** by adding the **ENERGY METER**: extra functions to ensure maximum protection for the electric pump

ENERGY METER
MODULE



MONITORING OF ELECTRIC MOTOR PARAMETERS

Constant control for correct operation and maximum performance

- Current asymmetry
- Winding insulation
- Phase sequence and failure
- Starts per hour
- Dry run
- Mechanical seal failure
- Water presence in oil chamber (K+ pumps)

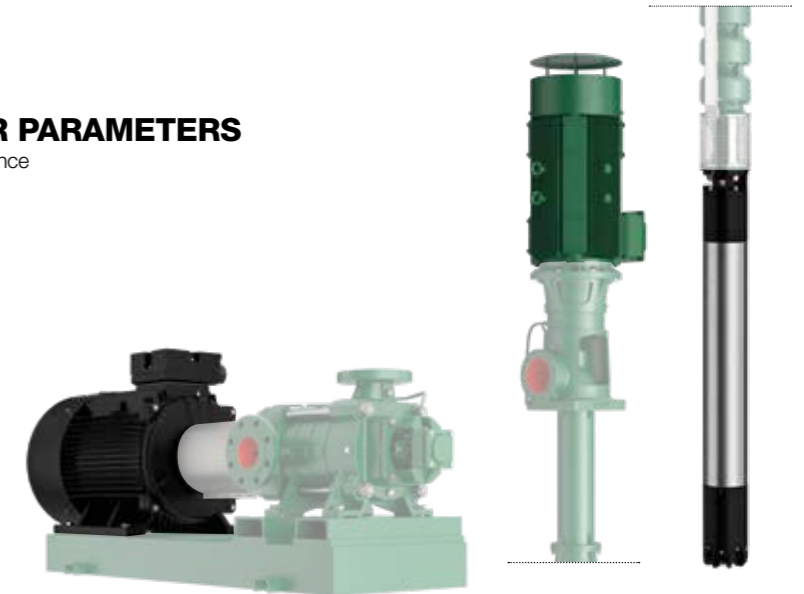

ANTI-CLOGGING FUNCTION

No more sudden blockages.

The integrated NON STOP anti-clogging function enables pump reverse rotation: the ideal solution in case of blockage caused by solids

- Electric pump stops and reverses rotation to attempt unblocking
- Restarts in normal rotation direction after clog is cleared

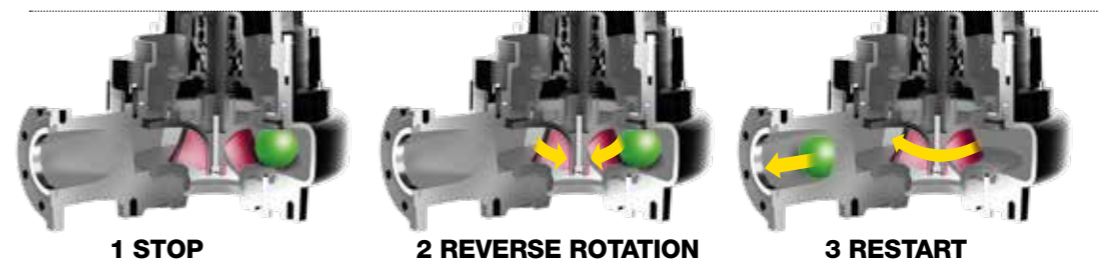

Electrical panels and frequency converters

Monitor and control your pumping system

Control panel

- Startings: direct, star-delta, stator impedance, with autotransformer, soft-starter, and inverter
- CapDRIVE: onboard frequency converter
- Customisation and dedicated accessories

VSD

The electrical panel with frequency converter guarantees:

- Reduced plant operating costs
- Speed regulation
- Water hammer prevention

CapDRIVE

Starting with onboard frequency converter:

- Easy installation
- Compact and robust
- Controls one or more pumps
- Combined operation with connection to other devices



global presence, local service

Since 1945, Caprari has been designing and manufacturing efficient and sustainable water pumping solutions, investing in technology and innovation. With a global presence and international sales network, we provide top-level support, ensuring quality, reliability, and rapid availability of products and spare parts worldwide.

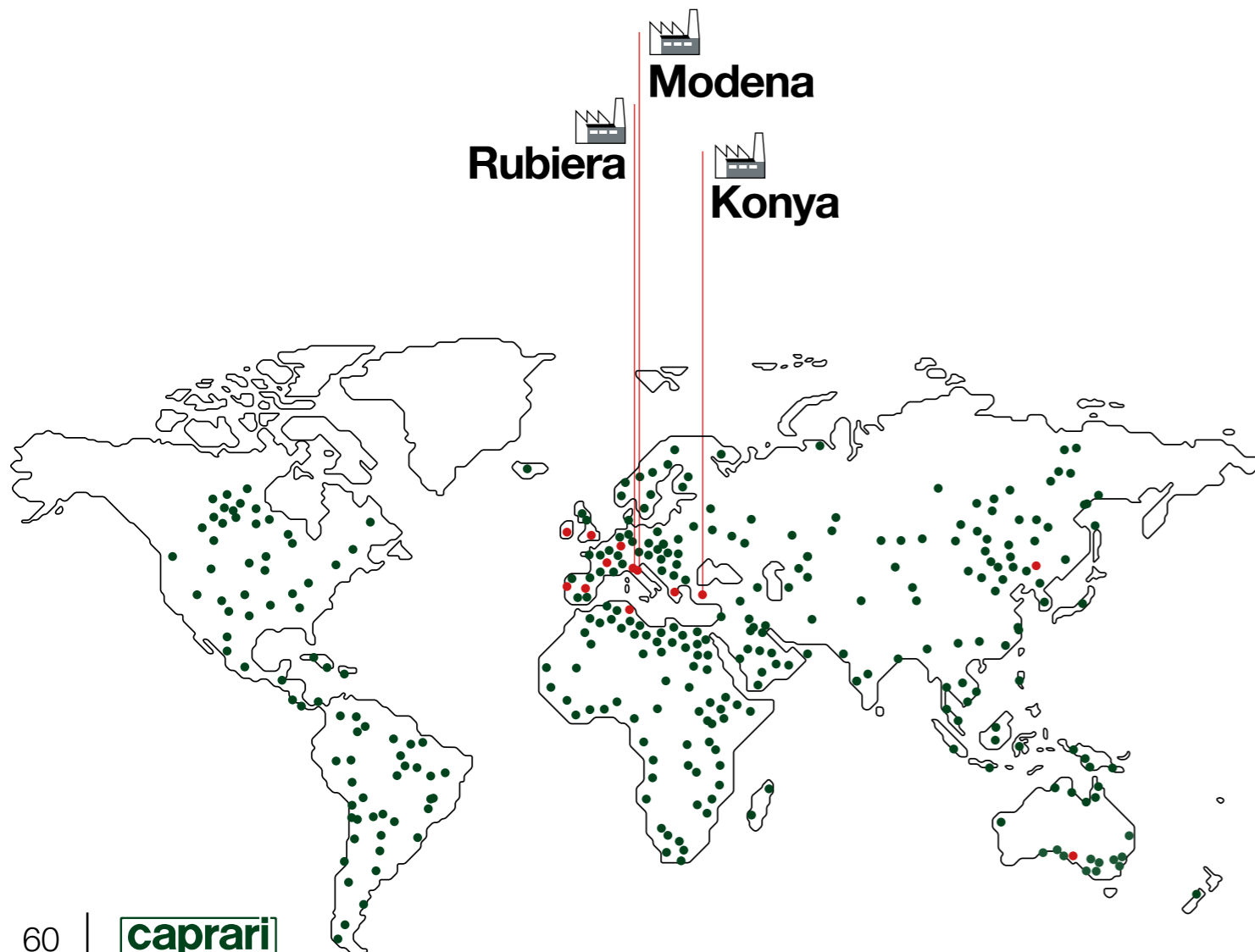

**fast
deliveries**
worldwide



**original
spare parts**
always available



**repairs and
maintenance**
on site and in the workshop

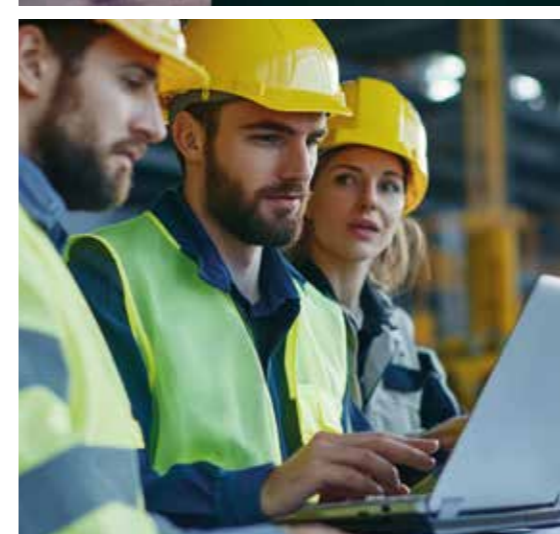

consulting
we collect your request
to create a tailor-made solution

**Caprari Italia**

Via Emilia Ovest, 900
41123 Modena (Italy)
Tel. +39 059 897611
e-mail: info@caprari.it

**Bombas Caprari SA**

C/Federico Chueca 5 - Polig. Ind. Santa Rosa
28806 Alcalá de Henares - Madrid (Spain)
Tel. +34 91 8895861
e-mail: info@bombascaprari.es

**Caprari France SAS**

60 Av. du Centre
78180 Montigny-le-Bretonneux, (France)
Tel. +33 1 30139270
e-mail: accueil@caprari.com

**Caprari Pumpen GmbH**

Kleemanngasse 15
D-90765 Fürth - Bayern (Germany)
Tel. +49 911 610930
e-mail: caprari@caprari.de

**Caprari Pumps (UK) LTD**

Caprari House - Bakewell Road - Orton Southgate
Peterborough PE2 6XU (Great Britain)
Tel. +44 1733 371605
e-mail: info@caprari.co.uk

**Caprari Hellas SA**

Industrial Area of Sindos
Municipality of Ehedorou
57022 Thessaloniki (Greece)
Tel. +30 2310 797967
e-mail: info@caprari.gr

**Caprari Portugal LDA**

Rua Matadouro Regional Lt 46 Armaz B/C
Zona Industrial
2005-002 Santarém (Portugal)
Tel. +351 243 350610
e-mail: geral@caprariportugal.pt

**Calpeda Pumps (Ireland) Ltd.**

Unit 5, Old Quarry Campus
Kilshane Park Blanchardstown
Co. Dublin 15 (Ireland)
Tel. +353 1 8612200
e-mail: info@calpedaireland.com

**Caprari Tunisie SA**

Rue Annaba - Z. Ind.elle Ben Arous
2013 Ben Arous (Tunisia)
Tel. +216 79 390001
e-mail: tunisie@caprari.com

**Caprari Pumps Australia PTY LTD**

no. 1 Maritime Court
5013 Gillman
South Australia (Australia)
Tel. +61 8 8290 0767
e-mail: sales@caprari.com.au

**Caprari Pumps (Shanghai) co. Ltd.**

1109 Shenneng International Plaza
No.1 Central Fuxing Rd
200011 Huangpu District, Shanghai (China)
Tel. +8621 5386 5192
e-mail: info@caprari.it

**HQ - Modena**

Via Guido Cavani 220
41123 Modena (Italy)
Tel. +39 059 897611

**Rubiera Plant**

Via Mantegna 6
42048 Rubiera - RE (Italy)

**Konya Plant**

Polmot Motor Makina San. Ve tic. A.S.
Büyük Kayacik
Mah. Organize Sanayi Bölgesi 103.
Cad. No :15 42300 Selcuklu Konya (Turkey)

caprari

Caprari S.p.A.

Via Emilia Ovest, 900

41123 Modena (Italy)

Tel. +39 059 897611

email: info@caprari.it

www.caprari.com

