

**caprari**

# PM-PMA

**HIGH PRESSURE  
MULTISTAGE  
HORIZONTAL PUMPS**

**DN50÷150**

**50/60Hz**

**EFFICIENCY**

**>80%**

**PRESSURES UP TO**

**100 bar**

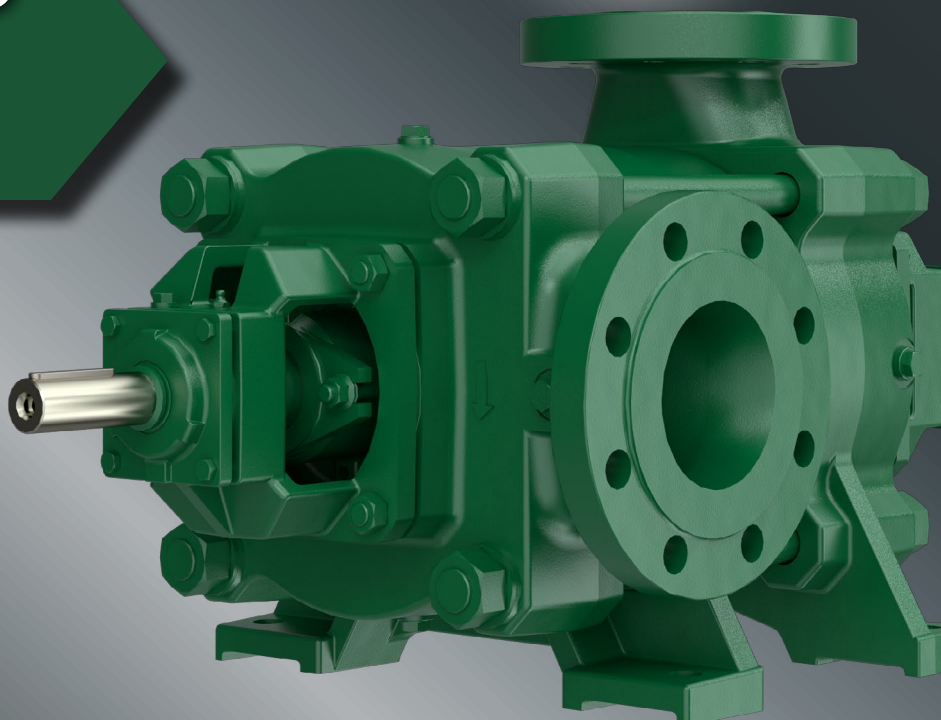
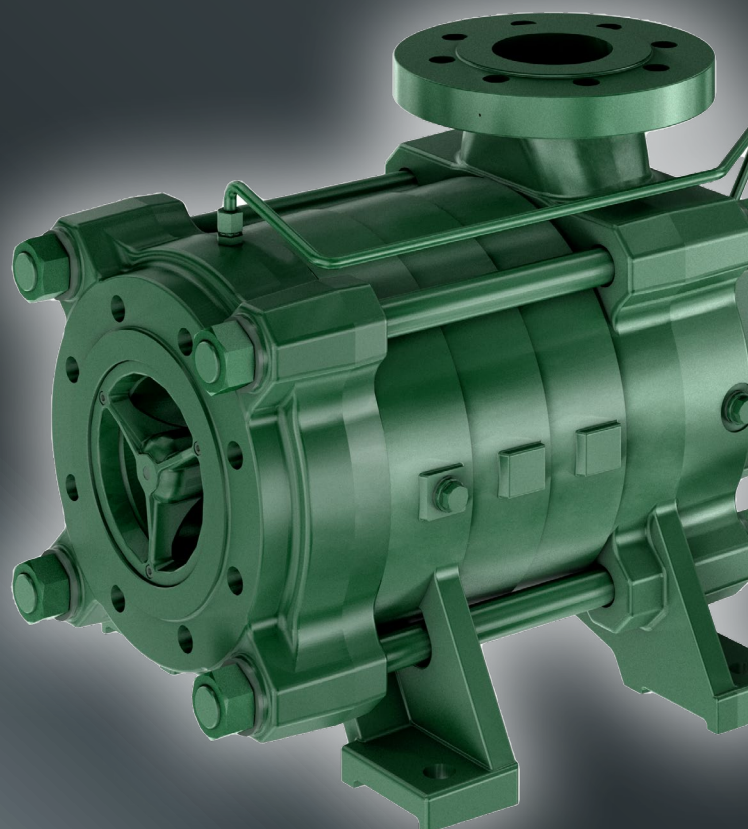

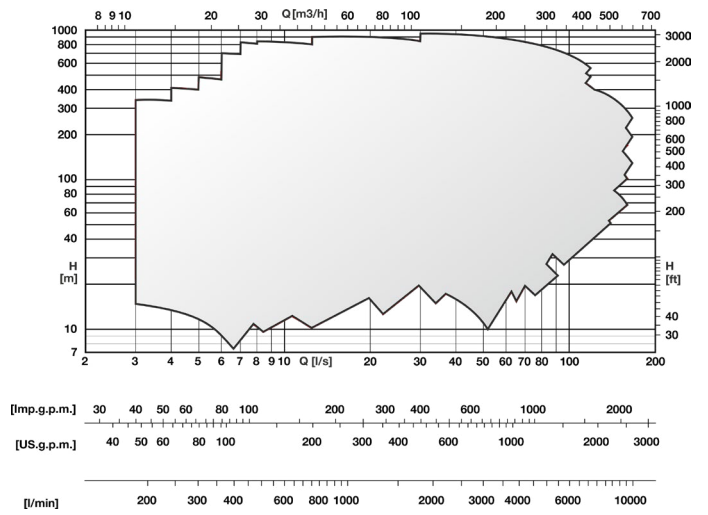
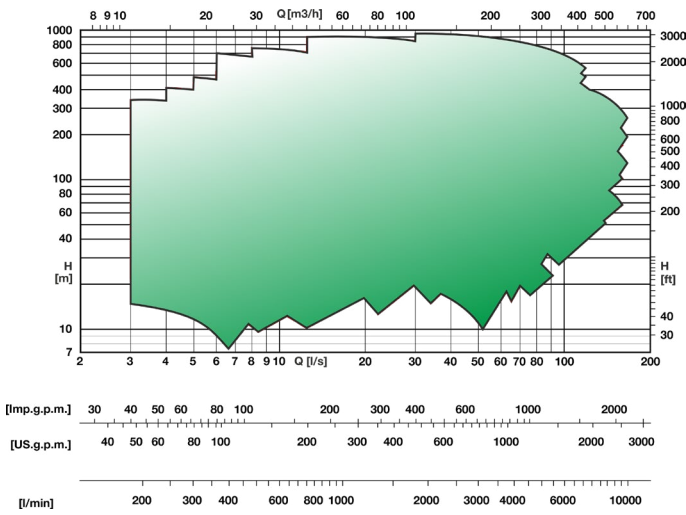
**50 Hz****60 Hz**

Sizes from-to	DNm 50 DNm 150
Flow Rate up to	160 l/s
Head up to	1000 m
Suction port	PN40
Delivery port	PN40 (PM) PN63 (PMS) PN100 (PMH)
Rotation speed	1.450 - 3.500 rpm

**IDEAL FOR****SNOWMAKING****WATER SUPPLY****INDUSTRIAL APPLICATIONS****FIRE-FIGHTING****IRRIGATION**

## WHY CHOOSE PM-PMA?

### 1 PRESSURE UP TO 100 BAR

- Impellers with **axial thrust compensation** system
- **High thicknesses** of the casting components and **high performance materials**

### 2 HIGH ENERGY SAVING

- **High-efficiency hydraulics:** best in class efficiency
- **Performance guaranteed over time:** replaceable wear rings

### 3 REDUCED INSTALLATION COSTS

- **Simple installation:** suction casing axial/radial to the pipeline
- **Easy pump-motor alignment:** innovative baseframes

### 4 LOW NPSH VALUES

- **Reduces the risk of cavitation**
- **Reliable** operation even in lifting installations

### 5 EASY MAINTENANCE

- **Reduced maintenance:** grease lubricated bearing on the delivery side
- **Quick replacement** of the sleeve and bushing from the suction side

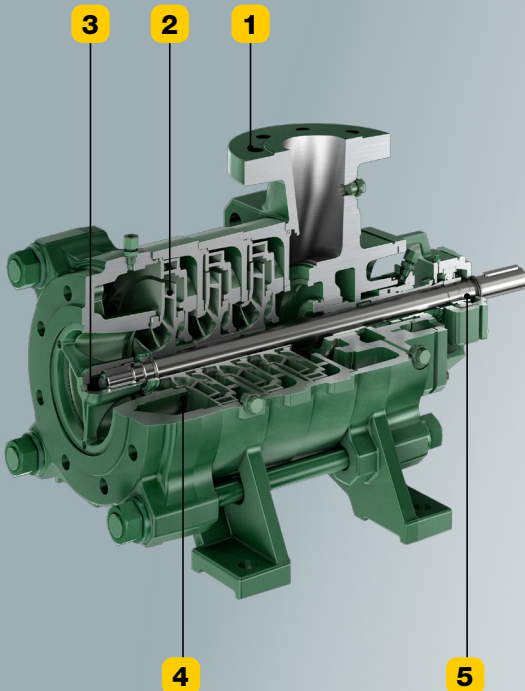
**caprari**

Follow us

